

## On Energy Optimisation in Multipurpose Batch Plants using Heat Storage

Thokozani Majozi<sup>a,b\*</sup> and Jane Stamp<sup>a,b</sup>

<sup>a</sup> Sustainable Process Systems Engineering, Department of Chemical Engineering,  
University of Pretoria, Lynnwood Road, Pretoria, 0002, South Africa

<sup>b</sup> Advanced Mathematical Modelling,  
Modelling and Digital Science, CSIR, Meiring Naude Road, Pretoria, 0002, South Africa

\*Corresponding Author's E-mail: [thoko.majozi@up.ac.za](mailto:thoko.majozi@up.ac.za)

**Keywords:** Heat integration; Heat storage; Multipurpose; Multiproduct; Energy optimisation.

### Abstract

The use of heat integration in multipurpose batch plants to minimise energy usage has been in the literature for more than two decades. Direct heat integration may be exploited when the heat source and heat sink processes are active over a common time interval. Indirect heat integration makes use of a heat transfer fluid for storing energy and allows heat integration of processes regardless of the time interval. This is possible as long as the source process takes place before the sink process thus allowing heat to be stored for later use. In both cases, heat transfer may only take place if the thermal driving forces allow. The use of heat storage instead of only direct heat integration leads to increased flexibility in the process and therefore improved energy usage. For present methods, the schedule tends to be fixed and as such, time is also fixed *a priori*, leading to sub-optimal results. The method presented in this paper treats time as a variable and consequently leads to improved results. Both direct and indirect heat integration are considered as well as the optimisation of the heat storage size and the initial temperature of the heat storage fluid. The mathematical formulation is based on an uneven discretization of the time horizon and the state sequence network (SSN) recipe representation. The resulting model exhibits the mixed integer nonlinear programming (MINLP) structure, which implies that global optimality cannot generally be guaranteed. However, a procedure is presented that seeks to find a globally optimal solution, even for nonlinear problems.

## 1. Introduction

Heat integration is widely used in continuous chemical plants. Most heat integration techniques assume steady state behaviour although even continuous processes are seldom at steady state. Batch processing has increased in popularity because it is more flexible and adaptable than continuous operations. Heat integration techniques specific to batch processes are therefore required. Some batch processes, such as those found in agrochemicals and pharmaceuticals, tend to be less energy intensive than continuous operations. However, processes such as those in dairies and brewing require significant external utilities [Mignon and Hermia, 1993].

## 2. Problem Statement

The problem addressed in this work can be stated as follows:

Given,

- (i) production scheduling data, including equipment capacities, duration of tasks, time horizon of interest, product recipes, cost of starting materials and selling price of final products
- (ii) hot duties for tasks requiring heating and cold duties for tasks that require cooling
- (iii) cost of hot and cold utilities
- (iv) operating temperatures of heat sources and heat sinks
- (v) minimum allowable temperature differences
- (vi) bounds on the heat storage capacity,

determine an optimal production schedule where the objective is to maximise profit, defined as the difference between revenue and the cost of hot and cold utilities. The size of heat storage available as well as the initial temperature of heat storage are also optimised.

## 3. Mathematical Model

The state sequence network recipe representation and an uneven discretization of the time horizon are used to model the process [Majozi and Zhu, 2001].

The model is based on the superstructure in Figure 1. Each task may operate in either integrated or stand alone mode. If either direct or indirect heat integration is not sufficient to satisfy a required duty, external utilities make up for any deficit. External utilities are also used if time or thermal driving forces do not allow for heat integration.

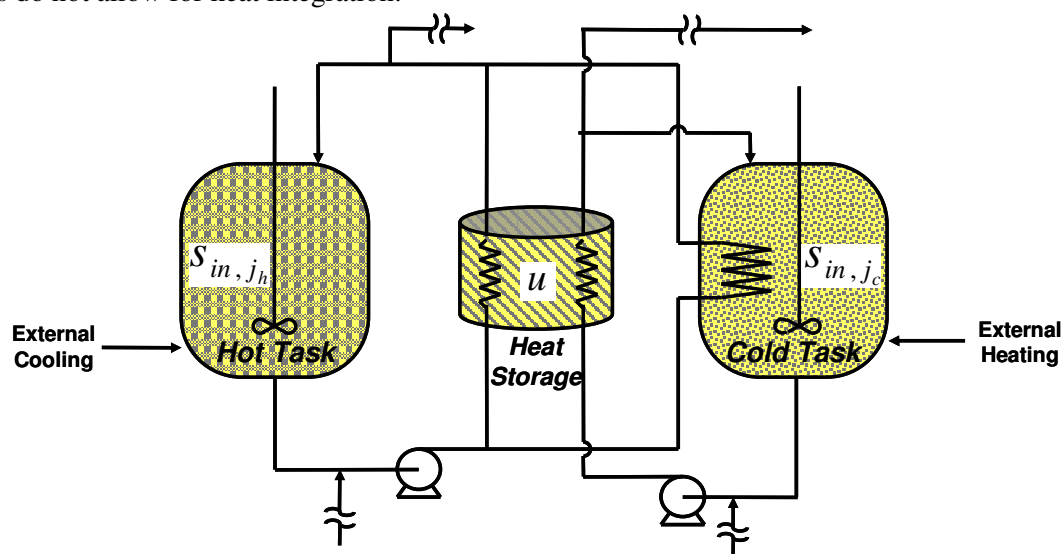

Figure 1: Superstructure for Mathematical Model

The mathematical model comprises the following sets, variables, parameters and constraints:

### Sets

$$J = \{ j \mid j \text{ is a processing unit} \}$$

$$J_c = \{ j_c \mid j_c \text{ is a processing unit which may conduct tasks requiring heating} \} \subset J$$

$$J_h = \{ j_h \mid j_h \text{ is a processing unit which may conduct tasks requiring cooling} \} \subset J$$

$$P = \{ p \mid p \text{ is a time point} \}$$

$$S = \{ s \mid s \text{ is any state} \}$$

$$S_{in,j} = \{ s_{in,j} \mid s_{in,j} \text{ is an input stream to a processing unit} \} \subset S$$

$$S_{out,j} = \{ s_{out,j} \mid s_{out,j} \text{ is an output stream from a processing unit} \} \subset S$$

$$U = \{ u \mid u \text{ is a heat storage unit} \}$$

### Variables

$$A_s(u) = \text{surface area of heat storage unit } u$$

$$cw(s_{in,j_h}, p) = \text{external cooling required by unit } j_h \text{ conducting the task corresponding to state } s_{in,j_h} \text{ at time point } p$$

$$Q(s_{in,j}, u, p) = \text{heat exchanged with heat storage unit } u \text{ at time point } p$$

$$st(s_{in,j_c}, p) = \text{external heating required by unit } j_c \text{ conducting the task corresponding to state } s_{in,j_c} \text{ at time point } p$$

$$T_0(u, p) = \text{initial temperature in heat storage unit } u \text{ at time point } p$$

$$t_{beg}(s_{in,j}, p) = \text{time at which heat storage unit commences activity}$$

$$t_{end}(s_{in,j}, p) = \text{time at which heat storage unit ends activity}$$

$$T_f(u, p) = \text{final temperature in heat storage unit } u \text{ at time point } p$$

$$\Delta T(u, p) = \text{temperature drop in heat storage unit } u \text{ due to heat losses}$$

$$t_u(s_{in,j}, p) = \text{time at which a stream enters unit } j$$

$$\Delta t = \text{time interval over which heat loss takes place}$$

$$W(u) = \text{capacity of heat storage unit } u$$

$$\Gamma(s_{in,j}, u, p) = \text{Glover transformation variable}$$

$$\Psi(s_{in,j}, u, p) = \text{linearisation-relaxation variable}$$

$$x(s_{in,j_c}, s_{in,j_h}, p) = \begin{cases} 1: & \text{if unit } j_c \text{ conducting the task corresponding to state } s_{in,j_c} \text{ is integrated} \\ & \text{with unit } j_h \text{ conducting the task corresponding to state } s_{in,j_h} \text{ at time} \\ & \text{point } p \\ 0: & \text{otherwise} \end{cases}$$

$$y(s_{in,j}, p) = \begin{cases} 1: & \text{if state } s \text{ is used in unit } j \text{ at time point } p \\ 0: & \text{otherwise} \end{cases}$$

$$z(s_{in,j}, u, p) = \begin{cases} 1: & \text{if unit } j \text{ conducting the task corresponding to state } s_{in,j} \text{ is integrated with} \\ & \text{storage unit } u \text{ at time point } p \\ 0: & \text{otherwise} \end{cases}$$

### Parameters

$\delta$  = a very small number

$c_p$  = specific heat capacity of heat storage fluid

$E(s_{in,j})$  = amount of heat required by or removed from unit  $j$  conducting the task corresponding to state  $s_{in,j}$

$h$  = convective heat transfer coefficient

$M$  = any large number

$T(s_{in,j})$  = operating temperature for processing unit  $j$  conducting the task corresponding to state  $s_{in,j}$

$T^L$  = lower bound for heat storage temperature

$T^U$  = upper bound for heat storage temperature

$\Delta T^{\min}$  = minimum allowable thermal driving force

$T_\infty$  = ambient temperature

$\tau(s_{in,j})$  = duration of the task corresponding to state  $s_{in,j}$  conducted in unit  $j$

$W^L$  = lower bound for heat storage capacity

$W^U$  = upper bound for heat storage capacity

### Constraints

In addition to the necessary short-term scheduling constraints [Majozi and Zhu, 2001], Constraints (1) to (23) constitute the heat integration model, useful for multipurpose batch processes with fixed batch sizes. Both direct and indirect heat integration are considered. Comparable formulations more suited to multiproduct facilities may be found in the literature [Majozi, 2006; Majozi, 2009].

Constraints (1) and (2) are active simultaneously and ensure that one hot unit will be integrated with one cold unit when direct heat integration takes place, in order to simplify operation of the process. Also, if two units are to be heat integrated at a given time point, they must both be active at that time point. However, if a unit is active, it may operate in either integrated or stand alone mode.

$$\sum_{s_{in,j_c}} x(s_{in,j_c}, s_{in,j_h}, p) \leq y(s_{in,j_h}, p), \quad \forall p \in P, \quad s_{in,j_h} \in S_{in,j} \quad (1)$$

$$\sum_{s_{in,j_h}} x(s_{in,j_c}, s_{in,j_h}, p) \leq y(s_{in,j_c}, p), \quad \forall p \in P, \quad s_{in,j_c} \in S_{in,j} \quad (2)$$

Constraint (3) ensures that only one hot or cold unit is heat integrated with one heat storage unit at any point in time.

$$\sum_{s_{in,j_c}} z(s_{in,j_c}, u, p) + \sum_{s_{in,j_h}} z(s_{in,j_h}, u, p) \leq 1, \quad \forall p \in P, u \in U \quad (3)$$

Constraints (4) and (5) ensure that a unit cannot simultaneously undergo direct and indirect heat integration. This condition simplifies the operability of the process.

$$\sum_{s_{in,j_h}} x(s_{in,j_c}, s_{in,j_h}, p) + z(s_{in,j_c}, u, p) \leq 1, \quad \forall p \in P, s_{in,j_c} \in S_{in,j}, u \in U \quad (4)$$

$$\sum_{s_{in,j_c}} x(s_{in,j_c}, s_{in,j_h}, p) + z(s_{in,j_h}, u, p) \leq 1, \quad \forall p \in P, s_{in,j_h} \in S_{in,j}, u \in U \quad (5)$$

Constraints (6) and (7) quantify the amount of heat received from or transferred to the heat storage unit, respectively. The amount of heat in storage remains unchanged if no heat integration takes place with the heat storage unit. These constraints are active over the entire time horizon, where  $p$  is the current time point and  $p-1$  is the previous time point. The initial temperature of the heat storage fluid is then  $T_0(u, p_0)$ .

$$Q(s_{in,j_c}, u, p-1) = W(u)c_p(T_0(u, p-1) - T_f(u, p))z(s_{in,j_c}, u, p-1), \\ \forall p \in P, p > p_0, s_{in,j_c} \in S_{in,j}, u \in U \quad (6)$$

$$Q(s_{in,j_h}, u, p-1) = W(u)c_p(T_f(u, p) - T_0(u, p-1))z(s_{in,j_h}, u, p-1), \\ \forall p \in P, p > p_0, s_{in,j_h} \in S_{in,j}, u \in U \quad (7)$$

Constraint (8) is a feasibility constraint ensuring that if a unit is not integrated with heat storage, the associated duty should not exist.

$$\delta z(s_{in,j}, u, p) \leq Q(s_{in,j}, u, p) \leq \max_{s_{in,j}}(E(s_{in,j_c}), E(s_{in,j_h})) z(s_{in,j}, u, p) \\ \forall p \in P, s_{in,j_c}, s_{in,j_h} \in S_{in,j}, u \in U \quad (8)$$

Constraint (9) ensures that the final temperature of the heat storage fluid at any time point becomes the initial temperature of the heat storage fluid at the next time point. This condition will hold regardless of whether or not there was heat integration at the previous time point.

$$T_0(u, p) = T_f(u, p), \quad \forall p \in P, u \in U \quad (9)$$

Constraints (10) and (11) ensure that the temperature of the heat storage fluid does not change if there is no heat integration with the heat storage unit, unless there is heat loss from the heat storage unit.  $M$  is any large number, thereby resulting in an overall “Big  $M$ ” formulation.

$$T_0(u, p-1) \leq T_f(u, p) + \Delta T(u, p) + M \left( \sum_{s_{in,j_c}} z(s_{in,j_c}, u, p-1) + \sum_{s_{in,j_h}} z(s_{in,j_h}, u, p-1) \right),$$

$$\forall p \in P, p > p_0, u \in U \quad (10)$$

$$T_0(u, p-1) \geq T_f(u, p) + \Delta T(u, p) - M \left( \sum_{s_{in,j_c}} z(s_{in,j_c}, u, p-1) + \sum_{s_{in,j_h}} z(s_{in,j_h}, u, p-1) \right),$$

$$\forall p \in P, p > p_0, u \in U \quad (11)$$

Heat losses from the heat storage unit depend on the initial temperature in the heat storage unit, the ambient temperature, the surface area of the tank and the time interval over which heat is lost. Combining Newton’s law of cooling and an enthalpy balance for the heat storage unit, Constraint (12) gives the temperature drop due to convective heat losses, applicable in Constraints (10) and (11).

$$\Delta T(u, p) = \frac{hA_s(u)(T_0(u, p-1) - T_\infty)\Delta t}{W(u)c_p}$$

$$\forall p \in P, p > p_0, u \in U \quad (12)$$

Constraint (13) ensures that minimum thermal driving forces are obeyed when there is direct heat integration between a hot and a cold unit.

$$T(s_{in,j_h}, p) - T(s_{in,j_c}, p) \geq \Delta T^{\min} - M(1 - x(s_{in,j_c}, s_{in,j_h}, p-1)),$$

$$\forall p \in P, p > p_0, s_{in,j_c}, s_{in,j_h} \in S_{in,j} \quad (13)$$

Constraints (14) and (15) ensure that minimum thermal driving forces are obeyed when there is heat integration with the heat storage unit. Constraint (14) applies for heat integration between heat storage and a heat sink, while constraint (15) applies for heat integration between heat storage and a heat source.

$$T_f(u, p) - T(s_{in,j_c}) \geq \Delta T^{\min} - M(1 - z(s_{in,j_c}, u, p-1)),$$

$$\forall p \in P, p > p_0, s_{in,j_c} \in S_{in,j}, u \in U \quad (14)$$

$$T(s_{in,j_h}) - T_f(u, p) \geq \Delta T^{\min} - M(1 - z(s_{in,j_h}, u, p-1)),$$

$$\forall p \in P, p > p_0, s_{in,j_h} \in S_{in,j}, u \in U \quad (15)$$

Constraint (16) states that the cooling of a heat source will be satisfied by either direct or indirect heat integration as well as external utility if required. Constraint (17) is the equivalent for the heating requirement of a heat sink.

$$\begin{aligned}
 Q(s_{in,j_h})y(s_{in,j_h}, p) &= Q(s_{in,j_h}, u, p) + cw(s_{in,j_h}, p) \\
 &+ \sum_{s_{in,j_c}} \min_{s_{in,j_c}, s_{in,j_h}} \{E(s_{in,j_c}), E(s_{in,j_h})\} x(s_{in,j_c}, s_{in,j_h}, p), \\
 &\forall p \in P, \quad s_{in,j_h} \in S_{in,j}, \quad u \in U
 \end{aligned} \tag{16}$$

$$\begin{aligned}
 Q(s_{in,j_c})y(s_{in,j_c}, p) &= Q(s_{in,j_c}, u, p) + st(s_{in,j_c}, p) \\
 &+ \sum_{s_{in,j_h}} \min_{s_{in,j_c}, s_{in,j_h}} \{E(s_{in,j_c}), E(s_{in,j_h})\} x(s_{in,j_c}, s_{in,j_h}, p), \\
 &\forall p \in P, \quad s_{in,j_c} \in S_{in,j}, \quad u \in U
 \end{aligned} \tag{17}$$

Constraints (18) and (19) ensure that the times at which units are active are synchronised when direct heat integration takes place. Starting times for the tasks in the integrated units are the same.

$$\begin{aligned}
 t_u(s_{in,j_h}, p) &\geq t_u(s_{in,j_c}, p) - M(1 - x(s_{in,j_c}, s_{in,j_h}, p)) \\
 &\forall p \in P, \quad s_{in,j_c}, s_{in,j_h} \in S_{in,j}
 \end{aligned} \tag{18}$$

$$\begin{aligned}
 t_u(s_{in,j_h}, p) &\leq t_u(s_{in,j_c}, p) + M(1 - x(s_{in,j_c}, s_{in,j_h}, p)) \\
 &\forall p \in P, \quad s_{in,j_c}, s_{in,j_h} \in S_{in,j}
 \end{aligned} \tag{19}$$

Constraints (20) and (21) ensure that the time a unit is active is equal to the time a heat storage unit starts either to transfer or receive heat.

$$\begin{aligned}
 t_u(s_{in,j}, p) &\geq t_{beg}(s_{in,j}, u, p) - M(y(s_{in,j}, p) - z(s_{in,j}, u, p)) \\
 &\forall p \in P, \quad u \in U, \quad s_{in,j} \in S_{in,j}
 \end{aligned} \tag{20}$$

$$\begin{aligned}
 t_u(s_{in,j}, p) &\leq t_{beg}(s_{in,j}, u, p) + M(y(s_{in,j}, p) - z(s_{in,j}, u, p)) \\
 &\forall p \in P, \quad u \in U, \quad s_{in,j} \in S_{in,j}
 \end{aligned} \tag{21}$$

Constraints (22) and (23) state that the time when heat transfer to or from a heat storage unit is finished will coincide with the processing time for a task added to the time the task started.

$$\begin{aligned}
 t_u(s_{in,j}, p-1) + \tau(s_{in,j})y(s_{in,j}, p-1) &\geq t_{end}(s_{in,j}, u, p) - M(y(s_{in,j}, p-1) - z(s_{in,j}, u, p-1)) \\
 &\forall p \in P, p > p_0, \quad u \in U, \quad s_{in,j} \in S_{in,j}
 \end{aligned} \tag{22}$$

$$\begin{aligned}
 t_u(s_{in,j}, p-1) + \tau(s_{in,j})y(s_{in,j}, p-1) &\leq t_{end}(s_{in,j}, u, p) + M(y(s_{in,j}, p-1) - z(s_{in,j}, u, p-1)) \\
 &\forall p \in P, p > p_0, \quad u \in U, \quad s_{in,j} \in S_{in,j}
 \end{aligned} \tag{23}$$

Constraints (6) and (7) have trilinear terms resulting in a nonconvex MINLP formulation. The bilinearity resulting from the multiplication of a continuous variable with a binary variable may be handled effectively with the Glover transformation. This is an exact linearisation technique and will not compromise the accuracy of the model [Glover, 1975]. The procedure is demonstrated for Constraint (7), leading to Constraints (24) to (27).

Let

$$T_f(u, p)z(s_{in,j_h}, u, p-1) = \Gamma_1(s_{in,j_h}, u, p) \quad (24)$$

And

$$T^L \leq T_f(u, p) \leq T^U \quad (25)$$

Then

$$\begin{aligned} T_f(s_{in,j_h}, u, p) - T^U(1 - z(s_{in,j_h}, u, p-1)) \\ \leq \Gamma_1(s_{in,j_h}, u, p) \leq T_f(s_{in,j_h}, u, p) + T^L(1 - z(s_{in,j_h}, u, p-1)) \end{aligned} \quad (26)$$

$$z(s_{in,j_h}, u, p-1)T^L \leq \Gamma_1(s_{in,j_h}, u, p) \leq z(s_{in,j_h}, u, p-1)T^U \quad (27)$$

The result is the addition of one new continuous variable and four new continuous constraints. The result from the Glover transformation is seen in Constraint (28).

$$\begin{aligned} Q(s_{in,j_h}, u, p-1) = W(u)c_p(\Gamma_1(s_{in,j_h}, u, p) - \Gamma_2(s_{in,j_h}, u, p-1)), \\ \forall p \in P, p > p_0, s_{in,j_h} \in S_{in,j}, u \in U \end{aligned} \quad (28)$$

The heat storage capacity,  $W(u)$ , is also a continuous variable and is multiplied with the continuous Glover transformation variable. This results in another type of bilinearity which may complicate the solution procedure. A method to handle this is a linearisation-relaxation technique [Quesada and Grossmann, 1995]. This is demonstrated for Constraint (28), resulting in Constraints (29) to (35).

Let

$$W(u)\Gamma_1(s_{in,j_h}, u, p) = \Psi_1(s_{in,j_h}, u, p) \quad (29)$$

And

$$W^L \leq W(u) \leq W^U \quad (30)$$

$$T^L \leq \Gamma_1(s_{in,j_h}, u, p) \leq T^U \quad (31)$$

Then

$$\Psi_1(s_{in,j_h}, u, p) \geq W^L\Gamma_1(s_{in,j_h}, u, p) + T^LW(u) - W^LT^L \quad (32)$$

$$\Psi_1(s_{in,j_h}, u, p) \geq W^U\Gamma_1(s_{in,j_h}, u, p) + T^UW(u) - W^UT^U \quad (33)$$



$$\Psi_1(s_{in,j_h}, u, p) \leq W^U \Gamma_1(s_{in,j_h}, u, p) + T^L W(u) - W^U T^L \quad (34)$$

$$\Psi_1(s_{in,j_h}, u, p) \leq W^L \Gamma_1(s_{in,j_h}, u, p) + T^U W(u) - W^L T^U \quad (35)$$

This is an inexact linearisation technique and increases the size of the model by one continuous variable and four continuous constraints. The full linearisation procedure is carried out for each of the four trilinear terms resulting from Constraints (6) and (7).

The linearised model is solved as a MILP, the solution of which is then used as a starting point for the exact MINLP model. If the solutions from the two models are equal, the solution is globally optimal, as global optimality can be proven for MILP problems. If the solutions differ, the MINLP solution is locally optimal. The possibility also exists that no feasible solution is found.

#### 4. Case Study

The state task network for the process is shown in Figure 2 and the state sequence network is shown in Figure 3. The scheduling data may be obtained from the literature [Majozi and Zhu, 2001]. The plant consumes 55% of the steam utility in an agrochemical facility. Each of the units processes a fixed batch size of eight tons, 80% of design capacity. The process requires three consecutive chemical reactions which take place in four available reactors. Reaction 1 takes place in either Reactor 1 or Reactor 2 and takes two hours. The intermediate from Reaction 1 is then transferred either to Reactor 3 or Reactor 4, where two consecutive reactions take place. Reaction 2 takes three hours and Reaction 3, one hour. Reaction 2 is highly exothermic and requires almost nine tons of cooling water (equivalent to 100 kWh). For operational purposes, these two consecutive reactions take place in a single reactor. Some of the intermediate from the first of these two reactions can be stored in an intermediate buffer tank prior to the final reaction to improve throughput. Both the second and third reactions form sodium chloride as a byproduct. The intermediate from Reaction 3 is transferred to one of three Settlers, to separate the sodium chloride from the aqueous solution containing the active ingredient. This process takes one hour. This salt-free solution is then transferred to one of two Evaporators, where steam (equivalent to 110 kWh) is used to remove excess water from the product, which takes three hours. This water is dispensed with as effluent. The final product is collected in storage tanks before final formulation, packaging and transportation to customers.

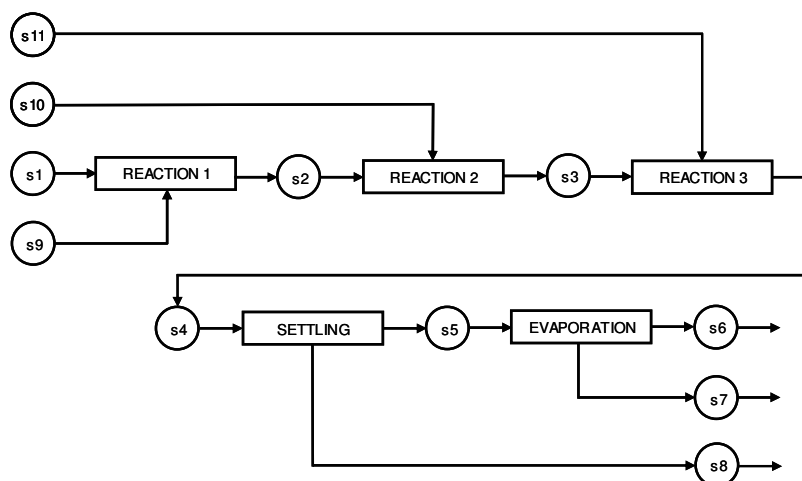
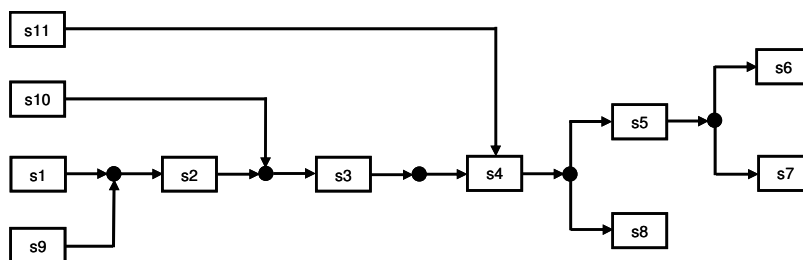

Figure 2: State Task Network of Industrial Case Study



**Figure 3: State Sequence Network of Industrial Case Study**

The temperatures for the exothermic second reaction (150°C) and endothermic evaporation stage (90°C) allow for possible heat integration. The size of the heat storage available and the initial temperature of the heat storage fluid will affect optimal energy use in the process.

Necessary data for the case study may be found in Table 1. Water was chosen as a heat storage fluid as its high heat capacity will provide good temperature control and facilitate easy heat recovery.

**Table 1: Data for Case Study**

Specific Heat Capacity of Water , $c_p$ (kJ/kg°C)	4.2
Production Cost (cu/ton)	10 000
Steam Cost (cu/kWh)	20
Cooling Water Cost (cu/kWh)	8

## 5. Results

In order truly to minimise energy, the heat that is stored in the heat storage unit should be reused later in the process. From Figure 4, it can be seen that this is achievable over the given time horizon. Heat integration is indicated with arrows. One heat storage unit was used and heat losses were not considered. The heat storage capacity and initial heat storage temperature were optimised.

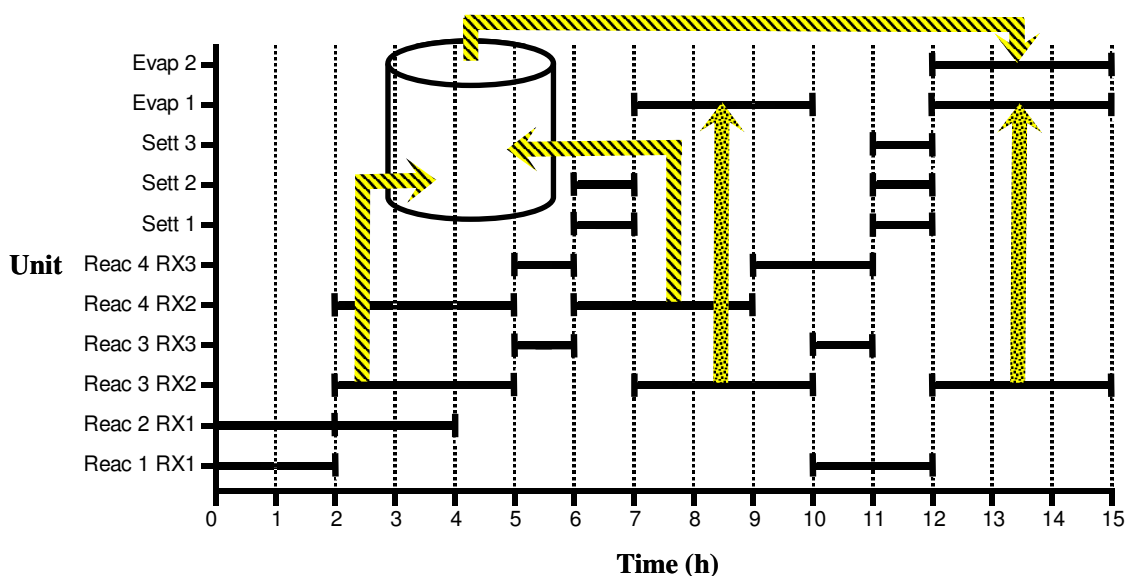

**Figure 4: Schedule with Improvement in Energy Usage**

For non-optimal values for the heat storage capacity and initial heat storage temperature, heat was stored, but not reused. From Figure 4, it is observed that heat which was stored in the heat storage unit is later used in the evaporation stage. The results for different scenarios are summarised in Table 2.

**Table 2: Results for Case Study**

	No Heat Integration	Direct Heat Integration Only	Indirect Heat Integration Only – Optimal Heat Storage Capacity	Direct and Indirect Heat Integration – Optimal Heat Storage Capacity
Performance Index (cost units) †	131 376.471	138 176.471	137 376.471	139 976.471
External Cold Duty (kWh)	400	300	200	100
External Hot Duty (kWh)	330	30	110	20
Heat Storage Capacity (ton)			1.048	0.524
Initial Heat Storage Temperature (°C)			99.543	54.091

† Performance Index = Revenue – Utility Costs

The solution procedure as described previously was used in solving the MINLP problems encountered for cases using heat storage. The results obtained from the linearised models were the same as for the exact models meaning the results obtained were globally optimal.

## 6. Conclusions

Using both direct heat integration and indirect heat integration via heat storage may significantly improve energy usage in a batch processing plant. This is due to an increase in flexibility in the process, since heat sources and heat sinks need not be active over a common time interval in order to exploit heat integration opportunities. The model presented in this paper leads to an optimum production and energy minimisation schedule. The size of the heat storage vessel as well as the initial temperature of the heat storage fluid affect optimality of the solution. Trilinear terms result in a nonconvex MINLP problem which may be challenging to solve.

## References

1. Glover F. Improved Linear Integer Programming Formulations of Nonlinear Integer Problems, *Man Sci*, **22** (4), 455-460, 1975.
2. Majozi T. and Zhu X. X. A Novel Continuous-time MILP Formulation for Multipurpose Batch Plants. 1. Short-term Scheduling, *Ind Eng Chem Res*, **40** (25), 5935-5949, 2001.
3. Majozi, T. Heat Integration of Multipurpose Batch Plants using a Continuous-time Framework, *App Therm Eng*, **26**, 1369 – 1377, 2006.
4. Majozi T. Minimization of Energy Use in Multipurpose Batch Plants using Heat Storage: An Aspect of Cleaner Production, *J Clean Prod*, **17**, 945-950, 2009.
5. Mignon D. and Hermia J. Using BATCHES for Modeling and Optimizing the Brewhouses of an Industrial Brewery, *Comput Chem Eng*, **17S**, S51-S56, 1993.
6. Quesada I. and Grossmann I. E. Global Optimization of Bilinear Process Networks with Multicomponent Flows, *Comput Chem Eng*, **19** (12), 1219-1242, 1995.