

**THE DEVELOPMENT AND EVALUATION OF A
PERFORMANCE-BASED STANDARDS APPROACH
FOR REGULATING THE USE OF HEAVY VEHICLES
IN SOUTH AFRICA**

Paul Anthony Nordengen

Submitted in fulfilment of the
requirement for the degree of PhD

College of Agriculture, Engineering and Science
University of KwaZulu-Natal

December 2013

Supervisor: Prof. P. Lyne

Co-Supervisor: Prof. C. Bezuidenhout

COLLEGE OF AGRICULTURE, ENGINEERING AND SCIENCE

As the candidate's Supervisor I agree/do not agree to the submission of this thesis.

Signed:

.....

DECLARATION 1 - PLAGIARISM

I, Paul Anthony Nordengen, declare that:

1. The research reported in this thesis, except where otherwise indicated, is my original research.
2. This thesis has not been submitted for any degree or examination at any other university.
3. This thesis does not contain other persons' data, pictures, graphs or other information, unless specifically acknowledged as being sourced from other persons.
4. This thesis does not contain other persons' writing, unless specifically acknowledged as being sourced from other researchers. Where other written sources have been quoted, then:
 - a. Their words have been re-written but the general information attributed to them has been referenced
 - b. Where their exact words have been used, then their writing has been placed in italics and inside quotation marks, and referenced.
5. This thesis does not contain text, graphics or tables copied and pasted from the Internet, unless specifically acknowledged, and the source being detailed in the thesis and in the References sections.

Signed:

.....

COLLEGE OF AGRICULTURE, ENGINEERING AND SCIENCE**DECLARATION 2 - PUBLICATIONS**

DETAILS OF CONTRIBUTION TO PUBLICATIONS that form part and/or include research presented in this thesis:

- De Saxe, C.C., Kienhöfer, F. and Nordengen, P.A. 2012. Tail swing performance of the South African car-carrier fleet. *Proceedings of the Twelfth International Symposium on Heavy Vehicle Transport Technology*. Stockholm, Sweden. (Co-author)
- De Saxe, C.C., Nordengen, P.A. and Kienhöfer, F. 2013. A performance-based standards scheme to regulate car-carriers in South Africa. *Proceedings of the 32nd Southern African Transport Conference*. Pretoria, South Africa. (Co-author)
- Dessein, T., Kienhöfer, F. and Nordengen, P.A. 2012. Determining the optimal performance-based standards heavy vehicle design. *Proceedings of the Twelfth International Symposium on Heavy Vehicle Transport Technology*, Stockholm, Sweden. (Co-author)
- Dessein, T., Nordengen, P.A. and Kienhöfer, F. 2010. A South African performance-based vehicle to transport steel pipes. *Proceedings of the Eleventh International Symposium on Heavy Vehicle Transport Technology*. Melbourne, Australia. (Co-author)
- Kienhöfer, F., Dessein, T. and Nordengen, P.A. 2012. The PBS assessment of a South African bi-articulated bus design. *Proceedings of the Twelfth International Symposium on Heavy Vehicle Transport Technology*, Stockholm, Sweden. (Co-author)
- Kienhöfer, F., Dessein, T. and Nordengen, P.A. 2012. The future of SA transport: designing road trains using multibody dynamics simulation. *Proceedings of the Eighth South African Conference on Computational and Applied Mechanics (SACAM 2012)*, Johannesburg, South Africa. (Co-author)
- Nordengen, P.A. and Oberholzer, F. 2006. A self-regulation initiative in heavy vehicle transport to address road safety, accelerated road deterioration and transport productivity in South Africa. *Proceeding of the Ninth International Symposium on Heavy Vehicle Weights and Dimensions*, Penn State University, State College, USA. (Main author)

- Nordengen, P.A., Prem, H., Mai, L. 2008. An initiative to introduce a performance-based standards (PBS) approach for heavy vehicle design and operations in South Africa, *Proceedings of the Tenth International Symposium on Heavy Vehicle Transport Technology*. Paris, France, pp. 61–70. (Main author)
- Nordengen, P.A. 2009. *Performance-Based Standards for heavy vehicles: Monitoring report on two PBS vehicles operating in the forestry industry: November 2007 to July 2008*. CSIR Built Environment, Pretoria, South Africa. (Main author)
- Nordengen, P.A. 2010. Monitoring results of two PBS demonstration vehicles in the forestry industry in South Africa. *Proceedings of the Eleventh International Symposium on Heavy Vehicle Transport Technology*. Melbourne, Australia. (Main author)
- Nordengen, P.A. 2010. Improving the road wear performance of heavy vehicles in South Africa using a performance-based standards approach. *Proceedings of the 16th International Road Federation World Meeting*. Lisbon, Portugal. (Main author)
- Nordengen, P.A. 2012. Monitoring results of PBS vehicles in South Africa in terms of productivity, safety and road wear performance. *Proceedings of the Twelfth International Symposium on Heavy Vehicle Transport Technology*, Stockholm, Sweden. (Main author)
- Nordengen, P.A. and Pienaar, N. 2008. The Road Transport Management System (RTMS) self-regulation initiative in heavy vehicle transport in South Africa. *Proceedings of the Transport Research Arena – Europe 2008*. Ljubljana, Slovenia. (Main author)
- Nordengen, P.A., Prem, H. and Lyne, P.W.L. 2009. *Performance-based standards (PBS) vehicles for transport in the agricultural sector*. Sugar Cane International, Vol. 27, No. 2. Tunbridge Wells, U.K. (Main author)
- Nordengen, P.A. and Roux, M.P. 2012. Improving the safety and road wear performance of heavy vehicles in South Africa using a performance-based standards approach. *Proceedings of the Transport Research Arena – Europe 2012*. Elsevier Ltd. Athens, Greece. (Main author)
- Nordengen, P.A. and Roux, M.P. 2013. Evaluation of a performance-based standards approach to heavy vehicle design to reduce pavement wear. *Proceedings of the 17th International Road Federation World Meeting*. Riyadh, Saudi Arabia. (Main author)
- OECD. 2011. *Moving Freight with Better Trucks: Improving Safety, Productivity and Sustainability*. ISBN 978-92-821-0293-0. OECD Publishing. Paris, France. (Co-author, Ch. 4 and Ch. 9; Member of Working Group and Editorial committee)

- Roux, M.P. and Nordengen, P.A. 2010. *Study on axle loads; turning circles; and lane widths for freight vehicles in sub-Saharan Africa: Final report*. CSIR Built Environment, Pretoria, South Africa. (Co-author)
- Woodrooffe, J., Glaeser, K-P. and Nordengen, P.A. 2010. Truck productivity, efficiency, energy use and CO2 output – international performance benchmarking. *Proceedings of the 89th Annual Transportation Research Board Meeting*. Washington, D.C., USA. (Co-author)

*To Charmaine, Ingrid, Jonathan and Mom
For your support and patience.*

ACKNOWLEDGEMENTS

I would like to acknowledge my supervisor, Prof. Peter Lyne, and my co-supervisor, Prof. Carel Bezuidenhout, for the professional way in which they have provided mentoring, guidance, support and encouragement during the past seven years.

For the implementation of the research for this thesis, I am indebted to the KwaZulu-Natal Department of Transport, in the persons of Chris Stretch, Senior Manager: Road Freight, Shane Millward and Kevin Robert, and to representatives of Mondi and Sappi, including Des Armstrong, Lorraine Lengton and Russell Morkel from Mondi and Robin Pretorius, Eric Aspeling and Hendrik de Jongh from Sappi, for supporting what initially appeared to be a high risk project. I would also like to acknowledge the national Department of Transport and the South African National Roads Agency Limited for their support of the PBS initiative and in particular, Skhumbuzo Macozoma, Prasanth Mohan and Geoff Ackermann. The commitment of these and others has made it possible for significant progress of the PBS initiative in South Africa.

I would like to acknowledge Brian Hunt, Managing Director of Timber Logistics Services and Francois Joubert, Managing Director of Timberology, for readily providing additional vehicle trip data and the explanation of various patterns and trends regarding their respective transport operations.

Further afield, I would like to acknowledge the Australian National Transport Commission, VicRoads, Melbourne, and Queensland Transport, Brisbane, for hosting the author on a number of occasions and for sharing valuable information and their experience regarding the PBS initiative in Australia. In addition, Dr Hans Prem, Mechanical System Dynamics, Melbourne, and Dr Peter Sweatman, Director, UMTRI, University of Michigan (previously Director, Road User Research, Melbourne), for sharing their experiences of PBS in Australia, and Les Bruzsa, of the National Heavy Vehicle Regulator and previously Queensland Transport, Brisbane, for sharing information and his very practical experience of PBS in Australia.

I would like to acknowledge Dr John de Pont, TERNZ, New Zealand, and John Billing, consultant to the National Research Council of Canada, for their assistance in providing relevant papers and reports and their insight regarding the PBS initiatives in New Zealand and Canada respectively. And Chris Winkler, University of Michigan Transport Research Institute, for sharing his extensive experience of vehicle dynamics during the author's visit

to UMTRI and during his two visits to South Africa to present the UMTRI vehicle dynamics course. And John Edgar, previously with the Australian National Road Transport Commission, for inviting the author to participate in the PBS seminar in Melbourne in 2003, which sparked the author's initial interest in the PBS approach to heavy vehicles.

I would like to thank the CSIR Built Environment for supporting my PhD research, involvement in the PBS national committee and PBS Review Panel and the PBS demonstration projects, through Parliamentary Grant funding. I would also like to thank my colleagues, Jenny Holloway, Michael Roux and Ismail Sallie for their assistance during the write-up of the thesis.

ABSTRACT

The regulation of the use of vehicles on the road network is aimed at ensuring acceptable safety and recovery of road maintenance costs, as well as minimising congestion, road wear, excessive noise and air pollution. The traditional approach of regulating heavy vehicles is prescriptive, *i.e.* enforcing regulations that primarily limit the mass and dimensions of these vehicles. This approach is generally favoured because such regulations are easy to understand and enforce. However, an underlying disadvantage is that the prescriptive approach does not always adequately safeguard the dynamic performance of heavy vehicles while travelling on the road. Principle-based and performance-based standards are primarily aimed at specifying desired outcomes, rather than how these outcomes should be achieved.

Under a performance-based standards (PBS) approach, performance measures (such as low-speed swept path, rearward amplification, load transfer ratio and high-speed offtracking) are utilised to specify the performance required from vehicles. Although more complex to regulate, a PBS approach has a number of potential benefits such as: (a) improved vehicle safety, (b) improved productivity, (c) reduced infrastructure wear and emissions, (d) a more optimal use of the existing road network, and (e) the encouragement of innovation in vehicle design.

The aim of this research was to apply, refine and demonstrate an alternative approach to the design and operation of heavy vehicles in South Africa with improved outcomes in terms of road transport productivity, vehicle safety performance, emissions, congestion and preservation of road infrastructure. The research included the development and implementation of a PBS demonstration project in South Africa and the monitoring and evaluation of PBS demonstration vehicles operating in the forestry industry in the provinces of KwaZulu-Natal and Mpumalanga. Evaluation focused on improvements in productivity (fuel efficiency and trip reduction) and load control with reference to initial results regarding road wear and safety performance.

Results show a significant improvement in payload control and fuel efficiency of the PBS vehicles compared with the baseline vehicles. This also resulted in a reduction in CO₂ emissions per ton.km. Road wear assessments of PBS and baseline vehicles showed that in some cases a reduction in road wear of up to 200% per ton of payload can be achieved through the use of PBS vehicles. Safety assessment results of four PBS vehicle designs showed various shortcomings of prescriptive baseline vehicles in terms of the performance standards.

TABLE OF CONTENTS

	Page
ACKNOWLEDGEMENTS	vi
ABSTRACT	viii
GLOSSARY OF TERMS	xv
ABBREVIATIONS	xvi
1 INTRODUCTION	1
2 LITERATURE REVIEW	4
2.1 Regulatory principles and options	4
2.1.1 A comparison of regulatory and enforcement approaches	4
2.2 Development of performance-based standards for heavy vehicles in New Zealand	6
2.2.1 Incorporation of two performance standards into heavy vehicle regulations	7
2.2.2 The SRT calculator	8
2.2.3 Fleet performance in forestry	11
2.2.4 Vehicle dimensions and mass rule amendment.....	12
2.3 Development of performance-based standards for heavy vehicles in Canada.....	13
2.3.1 National bridge capacity study.....	14
2.3.2 Vehicle weights and dimensions study (1984 – 1986).....	15
2.3.3 Memorandum of Understanding regarding heavy vehicle weights and dimensions	17
2.3.4 Further developments since the Memorandum of Understanding	19
2.4 Development of performance-based standards for heavy vehicles in Australia.....	20
2.4.1 PBS initiative in Australia.....	20
2.4.2 Performance measures and standards (Phase A).....	21
2.4.3 Regulatory and compliance processes (Phase B).....	23
2.4.4 Guidelines (Phase C).....	23
2.4.5 Legislation (Phase D).....	24
2.4.6 Case studies (Phase E)	24
2.4.7 Implementation (Phase F)	24
2.4.8 Intelligent Access Programme	25
2.4.9 National Heavy Vehicle Regulator	25
2.4.10 Conclusions.....	25

2.5	Discussion and conclusions	26
3	DEVELOPMENT OF A PBS PROJECT FRAMEWORK FOR SOUTH AFRICA	28
3.1	Background.....	28
3.1.1	The Road Transport Management System (RTMS)	29
3.1.2	PBS committee structures	30
3.1.3	Operation requirements for PBS demonstration vehicles on the South African road network	30
3.1.4	PBS strategy	31
3.2	Safety performance standards.....	32
3.2.1	PBS assessors.....	33
3.3	Infrastructure performance standards	34
3.3.1	Mass and dimensional limitations for PBS demonstration vehicles	34
3.3.2	Road pavements	34
3.3.3	Bridge structures	36
3.4	Rules for application to participate.....	38
3.5	PBS demonstration vehicles	39
3.5.1	Forestry	39
3.5.2	Mining.....	42
3.5.3	Car-carriers.....	44
3.5.4	Other	45
4	METHODOLOGY.....	46
4.1	Vehicle trip monitoring.....	46
4.2	Data validation.....	49
4.3	Analysis of trip combination mass	50
4.4	Analysis of Fuel Efficiency	52
4.5	Payload efficiency	53
4.6	Road wear and safety performance.....	54
5	RESULTS AND DISCUSSION	55
5.1	Overview of PBS dataset.....	55
5.2	Trip combination mass	57
5.3	Fuel efficiency	66

5.4	Payload efficiency	70
5.5	Road wear	71
5.6	Safety performance improvements	74
6	DISCUSSION, CONCLUSIONS AND RECOMMENDATIONS	77
6.1	Conclusions	78
6.2	Recommendations for further research.....	82
6.2.1	Volume versus mass constraints for commodities (such as timber) with a variable bulk density	82
6.2.2	South African performance standard for roads	82
6.2.3	South African performance standard for road structures	82
6.2.4	Performance characteristics of the South African heavy vehicle fleet.....	83
6.2.5	Comparative analysis of crash rates.....	83
6.2.6	Prototype PBS designs	83
	REFERENCES.....	84
	APPENDIX A	100
	APPENDIX B	104
	APPENDIX C	113
	APPENDIX D1	124
	APPENDIX D2	126
	APPENDIX D3	133
	APPENDIX D4	137
	APPENDIX D5	139

LIST OF TABLES

	Page
Table 2-1 Performance measures adopted in Canada as a basis for defining improved heavy vehicle configurations for inter-provincial operations.....	17
Table 2-2 Phases of the PBS initiative in Australia (Rolland <i>et al.</i> , 2006).....	21
Table 2-3 Safety standards and performance levels for PBS vehicles in Australia (NTC, 2008a). Definitions of terms are described by ARTSA (2003).....	22
Table 2-4 Infrastructure standards for PBS vehicles in Australia (NTC, 2008a).....	22
Table 3-1 Operational PBS vehicles in the forestry industry as at November 2013.....	42
Table 3-2 Operational and planned PBS vehicles in the mining industry as at November 2013.....	44
Table 3-3 Operational PBS vehicles in the car-carrier industry as at November 2013.....	45
Table 3-4 Planned PBS vehicles in various industries as at November 2013.....	45
Table 4-1 Trips per vehicle combination category for forestry pulp mill dataset.....	48
Table 4-2 Vehicle trips per PBS permissible mass category for forestry pulp mill dataset....	48
Table 4-3 Vehicle trips per PBS operator for forestry pulp mill dataset.....	49
Table 4-4 Category A trips transferred to Category B dataset per PBS operator.....	50
Table 4-5 Summary of PBS data used for fuel efficiency analysis.....	52
Table 5-1 Summary statistics for PBS and non-PBS vehicles, Categories A to D and > 30 t for the sample period.....	60
Table 5-2 Height restrictions of prescriptive vehicles and three PBS demonstration vehicle designs.....	65
Table 5-3 Extent of overloading and under-loading of PBS operators for the sample period.....	65
Table 5-4 Trip savings of PBS demonstration vehicles compared with 56 t legal baseline vehicles, January 2011 to September 2013.....	66
Table 5-5 Fuel efficiency improvements and estimated fuel savings per PBS operator, January 2011 to September 2013.....	68

LIST OF FIGURES

	Page
Figure 2-1 Hierarchy of possible approaches to regulation (NRTC, 2001a).....	5
Figure 2-2 A comparison of Relative Crash Rate against Static Rollover Threshold (SRT) for all vehicles in New Zealand (de Pont et al., 2002a).....	7
Figure 2-3 A comparison of Relative crash rate against Dynamic Load Transfer Ratio (DLTR) for all vehicles in New Zealand (de Pont et al., 2002a).....	8
Figure 2-4 2-D truck model for SRT calculation (de Pont <i>et al.</i> , 2002c).....	9
Figure 2-5 Graphical solution of SRT for simple case with compliant suspension and tyres (adapted from Winkler <i>et al.</i> , 2000).....	10
Figure 2-6 Comparison of SRT calculator results with user-defined suspension parameters and Yaw–Roll results (de Pont <i>et al.</i> , 2002c).....	10
Figure 2-7 On-highway log truck rollovers per 100 million km in New Zealand over the period 1999 to 2004 (de Pont <i>et al.</i> , 2006)	12
Figure 2-8 Permissible dimensions for 5-axle tractor semitrailer (RTAC, 1988).....	18
Figure 2-9 Permissible masses for 8-axle B-double combination (RTAC, 1988).....	18
Figure 3-1 Eight flexible road pavement structures and their material properties used for the mechanistic analysis for the PBS road wear comparative analysis. Classification according to TRH14. (CSRA, 1985)	37
Figure 3-2 Layout of the 22 m baseline (legal) and initial Mondi (24 m) and Sappi (27 m) PBS demonstration vehicles	40
Figure 3-3 Mondi PBS demonstration vehicle	40
Figure 3-4 Sappi PBS demonstration vehicle.....	41
Figure 3-5 Mondi PBS demonstration vehicle Mk II (68.22 tons, 26.63 m).....	41
Figure 3-6 Mondi PBS demonstration vehicle Mk III (70 tons, 25.00 m)	42
Figure 3-7 Unitrans Mining baseline and PBS road trains (Richards Bay Minerals mining operation).....	43
Figure 5-1 Percentage of PBS vehicle trips and tons transported in the forestry pulp industry for 2011 (June – Dec), 2012 and 2013 (Jan – Sept)	56
Figure 5-2 PBS demonstration vehicle trips from 2008 to 2013 (2013 value projected from January to September 2013 data).....	56
Figure 5-3 PBS demonstration vehicle kms travelled from 2008 to 2013 (2013 value projected from January to September 2013 data).....	57
Figure 5-4 Distribution of trip combination mass for vehicle categories A to D for combination mass > 30 t.....	58
Figure 5-5 Trip combination mass distribution of RTMS/non-PBS < 56 t (Category E) and Non-RTMS < 56 t (Category F) vehicles	58
Figure 5-6 Distribution of trip combination mass for Timber Logistics Services (PMCM=67.5 t) and Timberology (PMCM=70 t).....	59
Figure 5-7 Trip combination mass distribution per timber species for Timberology, data sample from January 2011 to September 2013.....	62

Figure 5-8	A comparison of measurable (aligned) levels of under-loading for vehicle categories A to F.....	63
Figure 5-9	A comparison of measurable (aligned) levels of overloading for vehicle categories A to F.....	64
Figure 5-10	Histograms of fuel efficiency for baseline and PBS vehicles, January 2008 to September 2013	67
Figure 5-11	Average fuel efficiencies of PBS and baseline vehicles of the forestry PBS transport operators for the sample period	68
Figure 5-12	Fuel efficiencies of Timber Logistics Services' PBS and baseline vehicles operating in similar forestry areas in KwaZulu-Natal, July – September 2013.....	69
Figure 5-13	A comparison of Payload Efficiency Factors for SA forestry baseline and PBS vehicles with OECD study truck sample (source: OECD, 2011).....	70
Figure 5-14	A comparison of Payload Efficiency Factors for SA forestry baseline and PBS vehicles and common timber transport vehicles in different countries	71
Figure 5-15	Summary of forestry industry PBS road wear assessments.....	72
Figure 5-16	Summary of mining industry PBS road wear assessments.....	73
Figure 5-17	Summary of selected baseline and PBS vehicle assessment results for four vehicles	75

GLOSSARY OF TERMS

Acceleration capability. Ability of a vehicle to accelerate either from rest or to increase speed on a level road (no grade).

Directional stability under braking. The ability to maintain stability under braking.

Dynamic Load Transfer Ratio (DLTR). A measure of the load transfer from one side of a vehicle to the other during a rapid lane change manoeuvre.

Frontal swing. The maximum lateral outswing of the front outside corner of the prime mover and trailer in a prescribed 90° low-speed turn.

Gradeability. The ability of a vehicle to maintain a) forward motion and b) minimum speed on a specified grade.

Handling quality. The rate of response of steering to steering wheel input (standard still to be developed).

High-Speed Transient Offtracking (HSTO). The lateral distance that the last axle on the rear trailer tracks outside the path of the steer axle in a prescribed sudden evasive manoeuvre.

Low-speed swept path. The maximum width of the swept path in a prescribed 90° low-speed turn.

Rearward Amplification (RA). The degree to which the trailing unit(s) amplify or exaggerate lateral motions of the hauling unit.

Ride quality. Level of vibration to which a driver is exposed.

Startability. Ability of a vehicle to commence forward motion on a specified grade.

Static Rollover Threshold (SRT). The steady-state level of lateral acceleration that a vehicle can sustain during turning without rolling over.

Steer-tyre friction demand. The maximum friction level demanded of the steer-tyres of the hauling unit in a prescribed low speed turn.

Tail swing. The maximum lateral out-swing of the outside rear corner of the truck or trailer as the turn commences.

Tracking Ability on a Straight Path (TASP). The total swept width while travelling on a straight path, including the influence of variations due to crossfall, road surface unevenness and driver steering activity.

Yaw Damping Coefficient (YDC). The rate of decay of the 'sway' or yaw oscillations of the rearmost trailer after a single pulse steer input at the hauling unit.

ABBREVIATIONS

AASHTO	American Association of State Highway and Transportation Officials
ALTC	(South African) Abnormal Loads Technical Committee
ARRB	Australian Road Research Board (ARRB Group)
CCMTA	Canadian Council of Motor Transport Administrators
CSIR	Council for Scientific and Industrial Research
DoT	(South African) Department of Transport
FS	Frontal Swing
HSTO	High Speed Transient Offtracking
IAP	(Australian) Intelligent Access Programme
ITS	Intelligent Transport Systems
LEF	Load Equivalency Factor
LSSP	Low Speed Swept Path
MoU	Memorandum of Understanding
NHVAS	(Australian) National Heavy Vehicle Accreditation Scheme
NHVR	(Australian) National Heavy Vehicle Regulator
NRTA	(South African) National Road Traffic Act
NRTR	(South African) National Road Traffic Regulations
NRTC	(Australian) National Road Transport Commission
NTC	(Australian) National Transport Commission
OECD	Organisation for Economic Co-operation and Development
OEM	Original Equipment Manufacturer
PBS	Performance-Based Standards
PEF	Payload Efficiency Factor
PMCM	Permissible Maximum Combination Mass
RA	Rearward Amplification
RTAC	Road Transport Association of Canada
RTMS	Road Transport Management System
SAMDM	South African Mechanistic-Empirical Design and Analysis Methodology
SANRAL	South African National Roads Agency Limited
SRT	Static Rollover Threshold
STFD	Steer Tyre Friction Demand
TASP	Tracking Ability on a Straight Path
TS	Tail Swing
UMTRI	University of Michigan Transport Research Institute
VDM	Vehicle Dimensions and Mass (New Zealand)
vtpm	Vehicle trips per month
YDC	Yaw Damping Coefficient

1 INTRODUCTION

Worldwide the use of heavy vehicles on the public road network is predominantly regulated by prescriptive rules. These rules may differ substantially from country to country and even between jurisdictions in the same country (*e.g.* the USA), usually having a negative impact on road transport efficiency. Typically, the prescriptive approach involves setting tightly defined vehicle mass and dimension limits to ensure that (a) transport operators use vehicles that are safe, (b) do not cause unacceptable damage to the road infrastructure, and (c) do not disrupt traffic flows. Prescriptive standards are an indirect, yet simple, means of achieving specific safety and infrastructure preservation outcomes. However, having these standards in place does not guarantee that vehicles meet certain requirements for good safety performance. Safety issues, such as low-speed swept path, vehicle stability, handling and high-speed tracking are not directly evaluated with a prescriptive standards approach.

Under a performance-based standards (PBS) approach, performance measures (such as those mentioned above) and performance levels, which may vary for different categories of the road network, are utilised to specify the performance required from vehicles, rather than prescribing how this performance should be achieved. PBS allows longer and/or heavier vehicles to operate on parts of the road network, as long as the required safety and infrastructure performance standards are met. PBS encourages vehicle designers to use innovative approaches and the latest technologies to develop vehicle combinations that are more efficient in performing the required transport task. This performance-based approach results in a better match between the vehicles and the roads on which they operate, and inevitably results in vehicles that are safer and more road-friendly. Because PBS vehicles are normally operated under special permit conditions, more responsibility is placed on the operator to ensure compliance. Non-compliance may lead to the withdrawal of the right to operate PBS vehicles, resulting in generally improved levels of compliance. The PBS approach to regulation is well established in other sectors such as occupational health and safety, food standards and road construction and maintenance (OECD, 2005).

Usually, in an effort to improve road freight productivity, reduce congestion and vehicle emissions, improve road infrastructure protection, or a combination of these, most countries undertake a partial or comprehensive review of their mass and dimensions regulations for heavy vehicles every 10 to 20 years. During the past two decades a number of countries have considered a performance-based approach as part of their mass and dimension reviews. These include New Zealand (Edgar, 1995; de Pont *et al.*, 2002c), Canada (RTAC, 1986; RTAC 1988; Billing and Madill, 2010), Australia (Peters and Stevenson, 2000; Calvert, 2004; Edgar, 2004)

and the United States (US DoT, 2000; TRB, 2002; Fepke *et al.*, 2006a; Fepke *et al.*, 2006b). More recently, the European Parliament is reviewing a proposal by the EU Committee on Transport and Tourism to revise the permissible maximum masses and dimensions of heavy vehicles operating in the European Union (European Parliament, 2013). In addition, the Organisation for Economic Co-operation and Development (OECD) carried out a project entitled, “Moving Freight with Better Trucks: Improving Safety, Productivity and Sustainability” (OECD, 2007; Woodrooffe *et al.*, 2010; OECD, 2011). This project included a benchmarking survey of the safety and productivity performance of heavy vehicles in a number of OECD member countries, based on a selection of performance measures that have been adopted in New Zealand, Canada and Australia. Although not a member of the OECD, South Africa was invited to participate in this project because of its PBS initiative.

In countries where a PBS approach to heavy vehicle design and regulation has been adopted, various models have been implemented. These include (a) a generic PBS approach, which has the greatest potential for significant safety and productivity gains (Australian approach), (b) the incorporation of one or more performance standards into the prescriptive regulations (initial approach in New Zealand), (c) the development of *pro forma* PBS designs for common heavy vehicle configurations (Canadian approach and more recently New Zealand) and (d) a combination of the above (New Zealand).

Many of the references that have informed the research for this thesis have been drawn from a series of heavy vehicle symposia/conferences hosted by the International Forum for Road Transport Technology (IFRTT, www.road-transport-technology.org). The first International Symposium for Heavy Vehicle Weights and Dimensions (ISHVWD), was held in 1986 (see Section 2.3.3) with the most recent being held in 2012. This forum has been used to discuss the research on aspects of heavy vehicle dynamics, which forms the basis of the PBS approach regarding vehicle safety performance.

The aim of this research was to apply, refine and demonstrate an alternative approach to the design and operation of heavy vehicles in South Africa with improved outcomes in terms of road transport productivity, vehicle safety performance, emissions, congestion and preservation of road infrastructure. The research includes the development and implementation of a PBS demonstration project and the monitoring and evaluation of vehicles operating in the forestry industry in the provinces of KwaZulu-Natal and Mpumalanga. The evaluation focused on improvements in productivity (fuel efficiency and trip reduction) and load control with reference to initial results regarding road wear and safety performance.

Specific objectives included:

1. Review literature regarding the development and implementation of PBS approaches for heavy vehicles in various countries (Chapter 2).
2. Develop a framework for the design and operation of heavy vehicles in South Africa using a PBS approach as a demonstration project (This is summarised in Chapter 3).
3. Evaluate PBS and non-PBS vehicles operating in the forestry industry in terms of productivity, specifically payload optimisation, fuel efficiency and trip reduction (This is done in Chapters 4 and 5).
4. Provide initial results towards developing a South African road pavement infrastructure performance-based standard based on road wear assessments of PBS and baseline vehicles in the forestry and mining industries (Chapter 5, Section 5.5).
5. Provide assessment results highlighting improved safety performance of PBS demonstration vehicles compared with baseline vehicles (Chapter 5, Section 5.6).

2 LITERATURE REVIEW

2.1 Regulatory principles and options

The regulation of road use by vehicles is aimed at ensuring acceptable safety, recovery of road maintenance costs as well as minimising congestion, road wear, excessive noise and air pollution. The predominant approach worldwide for regulating the use of heavy vehicles is by prescriptive rules. However, as numerous new technologies have become available and more affordable for use on a large scale, other more optimal approaches to regulate heavy vehicles should be considered, as suggested in the OECD Report to Ministers on Regulatory Reform (OECD, 1997):

“All governments have a responsibility to review their own regulations and regulatory structures and processes to ensure that they promote efficiently and effectively the economic and social well-being of their people.”

“Incentives have too often favoured vocal rather than general interests, short term over long term views, pursuit of narrow mission goals at any cost, and use of detailed and traditional controls rather than flexible and innovative approaches.”

The introduction of improved regulation has a number of potential positive outcomes such as (OECD, 2005):

- (a) encouraging innovation,
- (b) providing a better match between vehicles and roads,
- (c) increasing regulatory transparency through more consistent and rational regulatory approaches,
- (d) improving performance through better controls on safety and infrastructure wear, and
- (e) improving compliance.

2.1.1 A comparison of regulatory and enforcement approaches

The various approaches to regulation and enforcement are shown in Figure 2-1 (NRTC, 2001a; OECD, 2005). The prescriptive standards approach involves detailed and inflexible regulations that are generally only indirectly related to the desired outcomes, *e.g.* vehicle performance. In this literature review, ‘performance’ refers to the impact of a vehicle in terms of safety – with regard to dynamic performance in particular, infrastructure preservation and productivity. However, enforcement of the regulations is simple and can be done on the road (*e.g.* with a tape measure and weighbridge). On the other extreme, principle-based standards are more flexible and specify only broad objectives. Outcomes are specified, rather than how they are to be achieved. Enforcement and compliance is more complex and may involve accreditation and

quality management systems to ensure compliance with the operating conditions, which are often specific to a particular vehicle configuration. On-road enforcement is supported by audits of management systems and other forms of monitoring (*e.g.* GPS tracking).

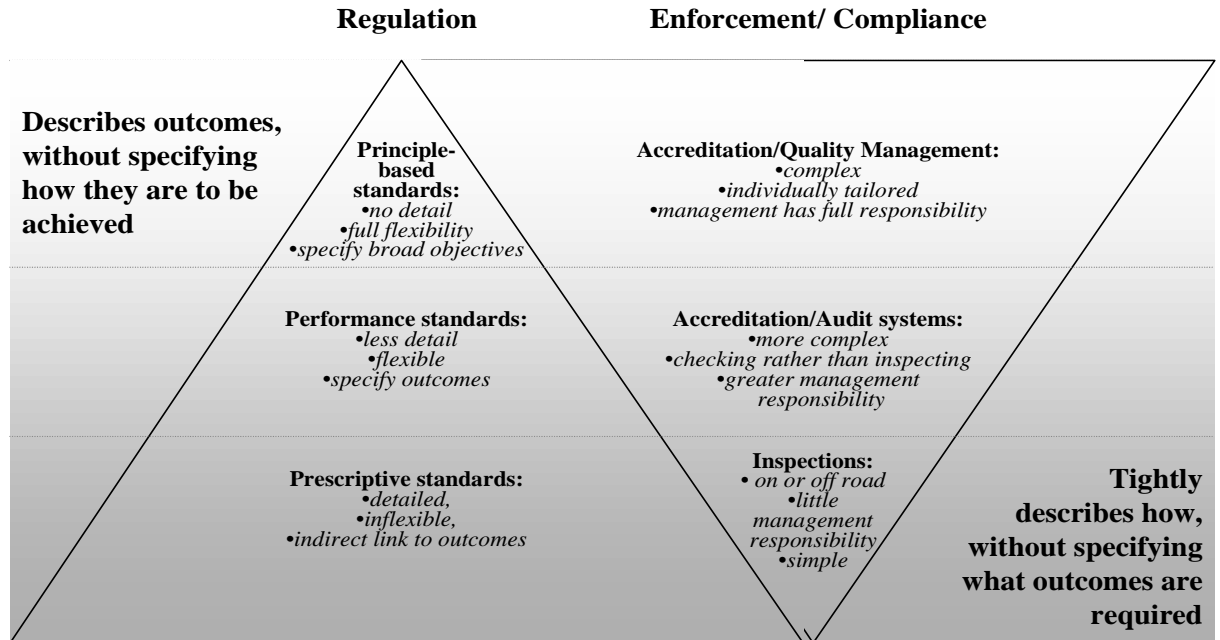

Figure 2-1 Hierarchy of possible approaches to regulation (NRTC, 2001a)

The PBS approach falls between the two extremes shown above. Performance-based standards are more precise than principle-based standards, but still allow sufficient flexibility regarding the manner in which the standards are achieved. Another regulatory approach is the introduction of performance-based prescriptive regulations that have been derived from PBS analyses. Under this approach, prescriptive rules are developed to achieve the same or similar outcomes that will meet specific performance criteria. This approach is likely to be less optimal than the PBS approach, as any innovative designs that do not meet the prescribed limits will not be allowed, even where the design meets the original performance criteria.

Six approaches for regulating the use of heavy vehicles have been identified (OECD, 2005):

- Prescriptive rules that have been developed over a long period of time and are most commonly used worldwide. They are usually not directly linked to performance criteria.
- The use of PBS as a basis for setting prescriptive rules.
- The use of PBS for evaluating and issuing exemption permits for vehicles exceeding the mass and dimension limits (abnormal loads).
- A holistic PBS approach which replaces prescriptive regulations with a PBS approach.

- A hybrid PBS approach which combines the advantages of the first three options. The majority of heavy vehicles would continue to operate in accordance with prescriptive rules; new vehicle combinations that meet either specified performance standards or modified prescriptive rules that are based on performance-based standards would be allowed to operate on specified sections of the road network.
- A road network approach, where varying performance levels for specific performance measures are assigned to different parts of the road network, thereby ensuring that lower road standards are matched by vehicles with improved performance. This approach may allow all existing vehicles access to the entire network, but with varying operating conditions on different sections of the network.

If successfully implemented, a regulatory framework for heavy vehicles incorporating a PBS approach is more likely to result in improved productivity, enhanced road safety and reduced negative environmental impacts (Peters and Stevenson, 2000; Bennett *et al.*, 2003). This will be achieved by:

- Permitting the operation of safer, higher productivity vehicles controlled by critical performance measures such as rollover stability.
- More closely matching heavy vehicles and the roads on which they travel.
- Reducing the total emissions of the heavy vehicle fleet.
- Encouraging innovation in the heavy vehicle industry to meet customer needs by providing a significant 'reward for effort'.
- Accelerating new vehicle and Intelligent Transport Systems (ITS) technology.
- Improving compliance with transport regulations.

2.2 Development of performance-based standards for heavy vehicles in New Zealand

New Zealand was the first country to implement performance standards for regulating heavy vehicles (OECD, 2005). In the late 1980s, New Zealand increased the permissible maximum combination mass (PMCM) for large vehicles from 39 to 44 t. This mass increase was limited to certain combinations, *viz.* B-trains and some truck-trailer configurations (Baas and White, 1989). The choice of vehicle configurations eligible for the 44 t combination mass was based on a PBS assessment. Subsequently, some A-trains were issued with permits for 44 t, provided they satisfied PBS criteria.

A government-initiated study on truck crashes in New Zealand (Anderson and Sinclair, 1996) identified the stability of trucks in the forestry industry as an area of particular concern. An analysis of crash statistics (Baas and Latto, 1997) showed that trucks in the forestry industry were involved in a disproportionately high number of crashes. The University of Michigan

Transport Research Institute (UMTRI) Yaw-Roll software was used to simulate a range of heavy vehicles under typical loading conditions and to evaluate a range of performance measures. Two of the critical performance measures identified with respect to rollover were Static Rollover Threshold (SRT) and Dynamic Load Transfer Ratio (DLTR). The results showed that many vehicle configurations commonly used in the forestry industry had poor performance in relation to these two measures (de Pont *et al.*, 2002a). The predominant vehicle configuration in the forestry industry in New Zealand is the rigid-drawbar (truck-trailer), which makes up about 90% of the timber vehicle fleet. The remainder are truck-semitrailers and interlinks (B-doubles).

2.2.1 Incorporation of two performance standards into heavy vehicle regulations

A study by White and Baas (1993) recommended a lower limit of SRT of 0.35 g and an upper limit of DLTR of 0.6 as benchmarks for acceptable performance. Marginal performance was defined as between 0.3 g and 0.35 g for SRT and between 0.6 and 0.8 for DLTR. Further studies (Mueller *et al.*, 1999; de Pont *et al.*, 2000) investigated various performance measures in relation to crash rates in New Zealand. The results showed a clear relationship between relative crash rate and SRT (Figure 2-2) and crash rate and DLTR (Figure 2-3).

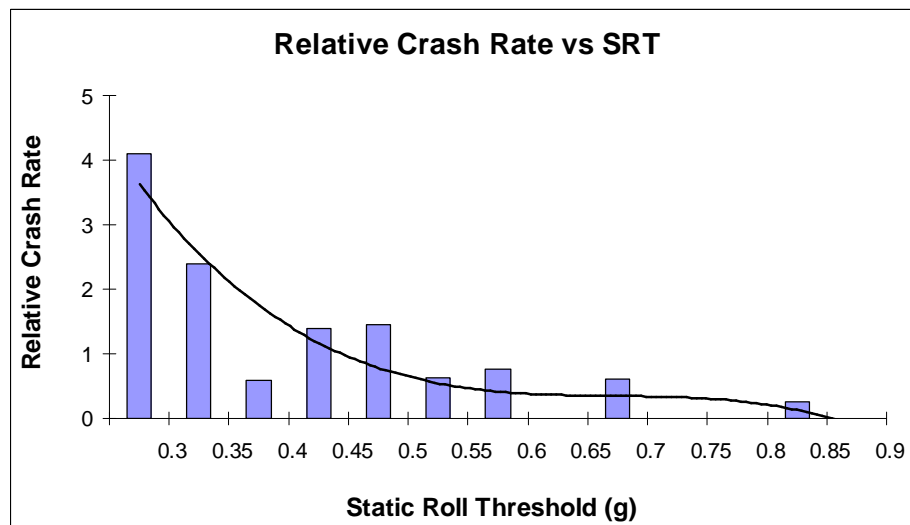

Figure 2-2 A comparison of Relative Crash Rate against Static Rollover Threshold (SRT) for all vehicles in New Zealand (de Pont *et al.*, 2002a)

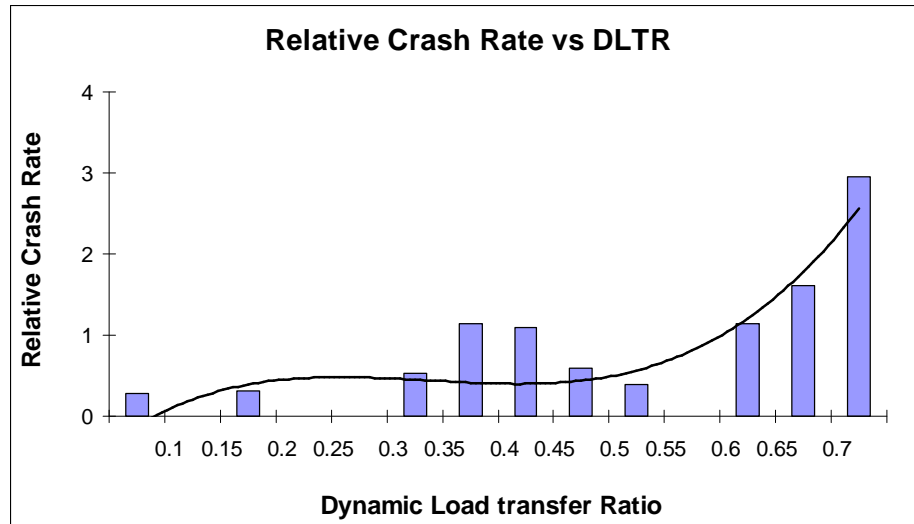

Figure 2-3 A comparison of Relative crash rate against Dynamic Load Transfer Ratio (DLTR) for all vehicles in New Zealand (de Pont et al., 2002a)

The above studies formed an important input to the Vehicle Dimensions and Mass (VDM) Rule 41001 (LTSA, 2002), which came into effect on 1 July 2002. For the first time anywhere in the world, so-called prescriptive regulations included a minimum rollover stability requirement for most heavy vehicles in the fleet. Some countries do have minimum stability requirements for certain categories of vehicles. For example, in the United Kingdom, there is a stability requirement for buses and coaches (HMSO, 1922) and in the European Union for tankers (ECE, 2001). Furthermore, in many countries, including South Africa, stability checks are required for abnormal vehicles carrying indivisible loads if the height to width ratio exceeds a certain limit (DoT, 2010).

2.2.2 The SRT calculator

The stability requirement in the VDM Rule applies to all heavy trucks in the class NC (>12 tons) and class TD (greater than 10 tons). Heavy vehicles in these classes must achieve a minimum SRT of 0.35 g (de Pont *et al.*, 2004). In order to make this requirement possible for the industry, an SRT calculator was developed. This is a simple, low-cost method for assessing SRT (de Pont *et al.*, 2002b, de Pont *et al.*, 2002c) with reasonable accuracy. The basis of the SRT calculator is an algorithm which was derived from the formula for a vehicle subject to a lateral acceleration, α , when assuming small angles (see Figure 2-4):

$$SRT = \alpha = \left(\frac{T}{2H} \right) - \Phi \quad (2.1)$$

where

- T = track width [m]
 H = centre of gravity height [m]
 Φ = total roll angle due to compliance [radians]

A mathematical solution was developed based on the graphical approach by Chalasani (Winkler *et al.*, 2000) to estimate the actual SRT (see Figure 2-5). The SRT calculator runs as a web-based application on the internet (www.ltsa.govt.nz/srt-calculator).

The SRT calculator algorithm was validated using results of 10 years of computer simulation in New Zealand using the Yaw-Roll software from UMTRI, together with the results of tilt table tests on a log transport trailer. A comparison of Yaw-Roll and SRT calculator results is shown in Figure 2-6 (de Pont *et al.*, 2002c).

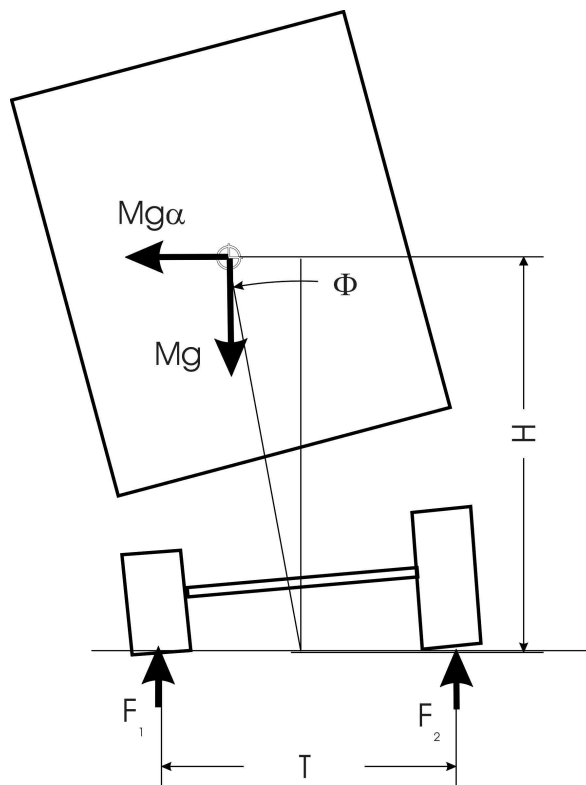

Figure 2-4 2-D truck model for SRT calculation (de Pont *et al.*, 2002c)

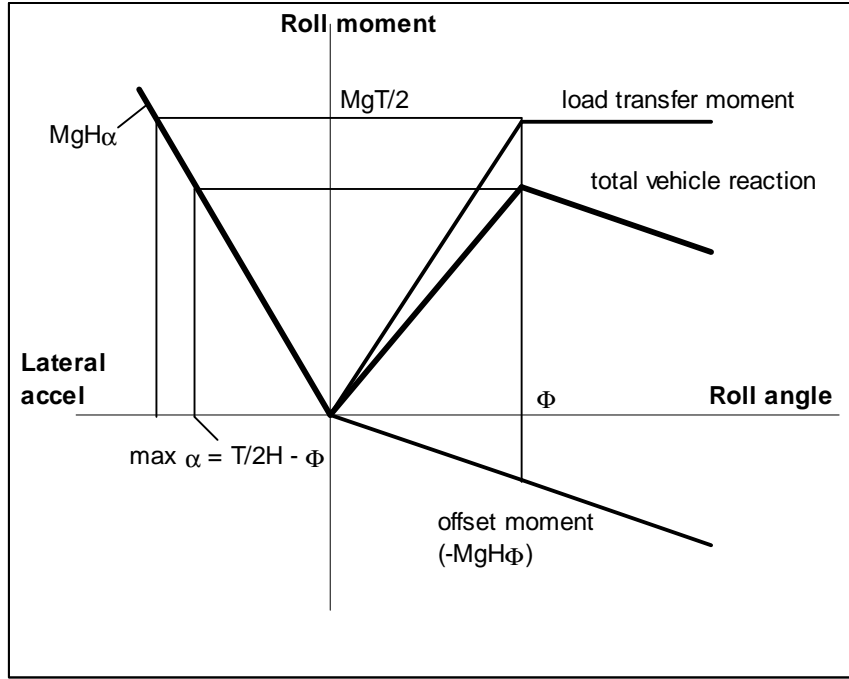

Figure 2-5 Graphical solution of SRT for simple case with compliant suspension and tyres (adapted from Winkler *et al.*, 2000)

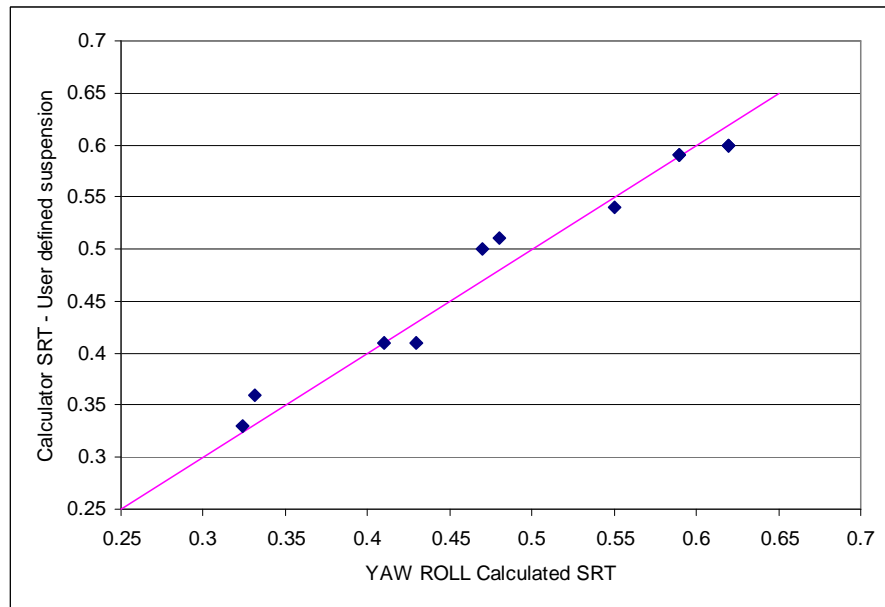

Figure 2-6 Comparison of SRT calculator results with user-defined suspension parameters and Yaw-Roll results (de Pont *et al.*, 2002c)

The advantage of this approach is that the minimum required inputs are generally known or easily measured by the transport operator.

2.2.3 Fleet performance in forestry

The incidence of rollover crashes per 100 million km travelled in the forestry industry in New Zealand has been on the decline since at least 1999 (de Pont *et al.*, 2006). Figure 2-7 shows this trend based on data from the New Zealand Police Commercial Vehicle Investigation Unit (CVIU) and the more extensive Log Transport Safety Council (LTSC) for the period 1999 to 2004. This significant reduction in crashes (more than 75% reduction from 2001 to 2004) can be attributed to a number of measures that have been implemented, including improvements in:

- (a) vehicle loading,
- (b) vehicle operations,
- (c) driver behaviour, and
- (d) company management.

Although the overall mass and dimension limits in New Zealand have not changed in the past 10 years, the following improvements in vehicle design have been implemented (de Pont *et al.*, 2006):

- Bolster bed heights are now typically up to 300 mm lower than previously, significantly improving rollover stability.
- Longer trailer wheelbases have further improved vehicle performance.
- Greater use of multi-bunk trailers. Almost all new trailers are now multi-bunk.
- Improved component design, including bolster design.
- The use of suspensions with a larger roll stiffness improving rollover stability and handling.

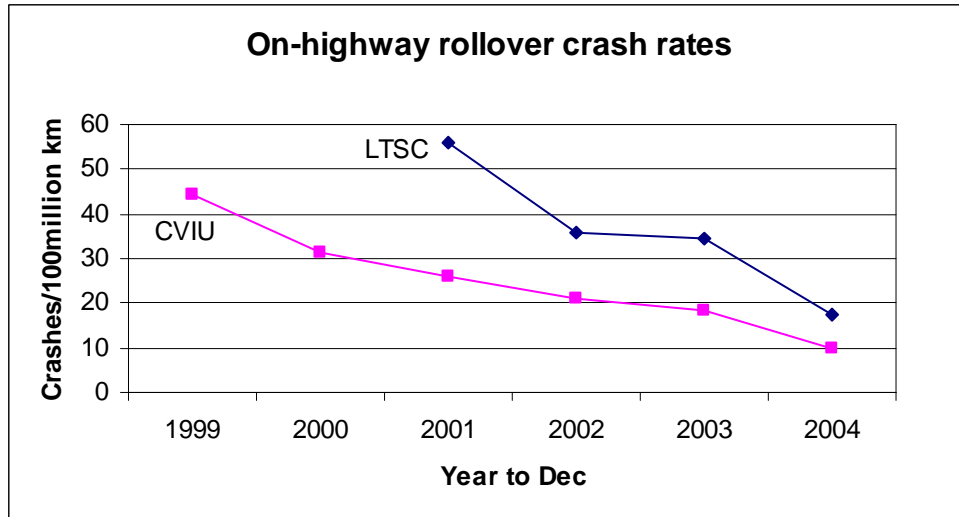

Figure 2-7 On-highway log truck rollovers per 100 million km in New Zealand over the period 1999 to 2004 (de Pont *et al.*, 2006)

The SRT of new trailers for transporting timber in New Zealand is now typically 0.42 *g*, compared with less than 0.35 *g* before the establishment of the LTSC and the subsequent initiatives to improve vehicle stability in the forestry industry.

In the road freight industry in general, fatal truck crashes per 100 million kilometres travelled declined by more than 50% from 1990 to 2003 (OAG, 2005).

2.2.4 Vehicle dimensions and mass rule amendment

In 2010 the New Zealand Transport Agency (NZTA), which was established on 1 August 2008 by the merging of Transit New Zealand and Land Transport New Zealand, published an amendment to the 2002 VDM Rule, which provides for High Productivity Motor Vehicles (HPMV) to operate at higher masses and lengths under permit (NZTA, 2010). These HPMVs must comply with a low-speed turning performance standard (120° turn with a 12.5 m outer radius and a minimum inner radius of 4.9 m). The 120° turn (rather than the more common 90° turn) was specified to take into account turns at roundabouts. In addition, HPMVs must comply with the following performance standards: Static Rollover Threshold, Rearward Amplification, Load Transfer Ratio, High Speed Transient Offtracking, Frontal Swing, Tail Swing, Steer Tyre Friction Demand, High Speed Steady Offtracking and Yaw Damping Ratio. Most of these performance standards are applied in the same manner as the Australian PBS scheme (NTC, 2008a).

In order to reduce development and implementation costs and facilitate the uptake of the VDM Rule amendment, the NZTA in co-operation with the New Zealand Truck and Trailer

Manufacturer's Federation, developed a series of *pro forma* designs, which is not dissimilar to the Canadian PBS approach (Section 2.3). Initially three *pro forma* designs were developed: a 22 m truck and drawbar trailer, a 22 m B-double and a 23 m truck and simple trailer (De Pont, 2010; De Pont, 2012). A number of additional *pro forma* designs have subsequently been developed. This approach makes provision for higher productivity vehicles that meet a number of specified dimensions and masses to operate as PBS vehicles on the road network without additional detailed analysis. However, operators may also opt for a higher productivity vehicle design that does not meet any of the *pro forma* design specifications, in which case a full performance analysis of the proposed vehicle combination is required. An example of a non-*pro forma* combination is a 24.5 m B-double that has a route specific permit to operate at 62 tons (De Pont, 2012).

The VDM Rule amendment came into effect on 1 May 2010 and as at May 2012, 984 HPMV permits had been issued, of which the vast majority are based on *pro forma* designs.

2.3 Development of performance-based standards for heavy vehicles in Canada

Prior to 1970, the regulations in Canada were simple and prescriptive. During the 1960s, primarily as a result of pressure from the trucking industry to be more competitive, mass and dimension limits in the province of Ontario were increased. In 1967 the Ontario Department of Transport undertook a truck mass and dimensions survey (Armstrong *et al.*, 1970) and found significant overloading of axles on heavy vehicles that were within or marginally over the permissible maximum vehicle/combination mass. The survey also found that, due to the absence of control on the spacing of axles, a large proportion of short trucks with closely spaced axles had the potential to be damaging to bridge structures. However, these vehicles did not appear to cause the distress to roads or bridges that would have been expected. The results of this survey led to further studies by the Ontario Department of Transport on the load carrying capacity of existing bridges, which resulted in the development of the Ontario Bridge Formula as a safe limit for heavy vehicle loads on bridges (Jung, 1969; Armstrong *et al.*, 1970; Jung and Witecki, 1971).

The Ontario Bridge Formula was included in the Highways Traffic Act in 1970. It allowed increased mass on axle units with a greater spread, especially on shorter heavy vehicles. It also allowed an increase in the axle load limits of about 10%. The permissible load on single axles was governed by pavement wear principles; the bridge formula extended this regulation to ensure safe loads on structures by limiting the load on a group of consecutive axles based on the axle spacing. The PMCM was increased from 55 338 kg (122 000 lb) to 63 503 kg (140 000 lb), while the permissible maximum overall length remained at 19.81 m (65 ft). The bridge formula

did not control vehicle configurations, and vehicle designers soon developed numerous new vehicle configurations to maximise payloads under the new regulations. The new configurations resulted in significant transport productivity improvements for industries involved in transporting bulk and heavy commodities (Agarwal and Billing, 1986).

2.3.1 National bridge capacity study

Because freight transport in Canada was primarily east-west prior to the Canada-USA Free Trade Agreement of 1988, Ontario's heavy vehicle mass increases in 1970 put pressure on other provinces to also implement increases. Other Canadian provinces thus increased their PMCMs during the 1970s. The three Prairie provinces and the four Atlantic provinces made changes to their regulations, resulting in considerable regional uniformity. However, significant differences remained between these two regions and the other three provinces. These changes in regulations tended to increase rather than decrease the diversity of heavy vehicle configurations in Canada. The 1973 oil crisis highlighted the need for improved road transport efficiency, which resulted in the Road Transportation Association of Canada (RTAC) forming a Vehicle Weights and Dimensions Committee with the aim of achieving uniformity in heavy vehicle masses, dimensions and vehicle configurations across Canada. The committee felt that there was insufficient clarity with regard to the live load capacity of bridges in Canada, particularly in terms of abnormal loads, and hence commissioned a national bridge capacity study (RTAC, 1980; cited in NCHRP, 2008). The study showed that provincial mass and dimension regulations followed Ontario's bridge formula fairly closely (Agarwal, 1978), which was not surprising considering that all provinces designed their bridges to the AASHTO (AASHTO, 1977) or Canadian Standards Association (CSA, 1978) codes.

When Ontario adopted the metric system in 1978, the regulations regarding the mass and dimensions of heavy vehicles were updated. A number of important changes were made at the same time including an increase in the permissible maximum length from 19.81 m (65 ft) to 21.0 m. In the early 1980s, the Ontario Commission of Truck Safety made a number of recommendations regarding vehicle dimensions, which resulted in an increase in the permissible maximum length from 21.0 to 23.0 m in 1983. However, there was a restriction on the kingpin-to-rear dimension for a double trailer combination in an attempt to reverse the trend of shortening truck tractor dimensions to maximise the trailer deck loading area.

The 1980 national bridge study had shown that further increases in axle unit and combination masses (towards the mass limits in Ontario) were possible, but most of the other provinces were not prepared to adopt the Ontario form of regulation, nor many of the truck configurations and axle arrangements (particularly liftable axles and tridem axle units) common in Ontario.

2.3.2 Vehicle weights and dimensions study (1984 – 1986)

The joint Committee on Heavy Vehicle Weights and Dimensions of the Road Transportation Association of Canada (RTAC) and the Canadian Council of Motor Transport Administrators (CCMTA), which represented the provincial transport ministries responsible for size and weight regulations, commissioned a multi-disciplinary research project in 1984 involving research on vehicle dynamic performance and pavement response to axle unit loads (RTAC, 1986). The project was funded jointly by all provinces and territories (50%), the federal government (25%) and industry (25%). The CCMTA/RTAC vehicle mass and dimensions study included (all references are cited in NCHRP, 2008):

- A simulation study of candidate configurations (Ervin and Guy, 1986a; Ervin and Guy, 1986b), supported by a small amount of full-scale testing (Ervin and Guy, 1986b), and other assessments of simulation methodology (Gagne, 1986; Wong and El-Gindy, 1986).
- A full-scale test programme (Billing, 1986a; Billing, 1986b), supported by a simulation study to compare simulation results of test conditions (Billing, 1986c), and a specific examination of C-train stability (Billing, 1986d).
- An evaluation of rollover thresholds of heavy vehicles using a tilt table (Delisle and Pearson, 1986), supported by a study of simplified means to assess the roll threshold (Bedard, 1986).
- A pavement test programme (Christison, 1986a; Christison, 1986b; Christison, 1986c), supported by an investigation of heavy truck suspension characteristics (Woodrooffe *et al.*, 1986b).

After completion of the research, a seminar was held to present the findings to stakeholders. The study generated international interest and remains one of the most significant heavy vehicle mass and dimension studies to date. The work was subsequently presented at the first International Symposium on Heavy Vehicle Weights and Dimensions held in Kelowna, British Columbia, in June 1986. This symposium has been succeeded by eleven others in eight countries, including South Africa.

Following the mass and dimension study, the CCMTA/RTAC committee formed an Implementation Planning Subcommittee in 1986, with the following tasks (NCHRP, 2008):

- Develop a plan to assist each jurisdiction in implementing vehicle mass, dimension and configuration regulatory principles that would lead to national uniformity.
- Develop schedules for proposed implementation of recommendations.

- Monitor the progress of the implementation of the recommendations as they may be agreed to by the Council of Ministers Responsible for Transportation and Highway Safety at its meeting in September 1987.

The Vehicle Weights and Dimensions Study provided a rational and objective means based on vehicle dynamic performance and pavement loading to define heavy vehicle mass and dimension parameters and vehicle configurations (RTAC, 1986). The national bridge study (RTAC, 1980; Agarwal, 1978) had established guidelines for regulating vehicle masses and dimensions in terms of structures, but the provinces had diverse approaches for assessing vehicle impacts on bridges. The Implementation Planning Subcommittee met with the provincial bridge engineers and agreed on various issues regarding axle unit masses, minimum inter-axle spacings and PMCMs.

The Implementation Planning Committee developed recommended regulatory principles, which provided improved opportunities to safely exploit the available capacities of both the highway system and the motor transport fleet on a national basis (RTAC, 1987). These principles took the following into consideration:

- (a) the findings of the research programme,
- (b) recognition of the safety of the users of the system,
- (c) engineering, economic and operational constraints of the highway system,
- (d) the operational requirements of the trucking industry, and
- (e) the capabilities of the truck and trailer manufacturing industries.

The regulatory principles were developed in the context of the following objectives:

- To encourage the use of the most stable heavy vehicle configurations through the implementation of practical, enforceable weight and dimension limits.
- To balance the available capacities of the national highway transportation system by encouraging the use of the most productive vehicle configurations relative to their impact on the infrastructure.
- To provide the motor transport industry with the ability to serve markets across Canada using safe, productive, nationally acceptable equipment.

The seven performance standards (and target performance levels) that form the basis of the regulatory principles are listed in Table 2-1. This was the first time that performance measures had been used to regulate vehicle design in Canada.

Table 2-1 Performance measures adopted in Canada as a basis for defining improved heavy vehicle configurations for inter-provincial operations

Performance measure	Target performance level
Static rollover threshold	Vehicles, in the loaded condition, should exhibit a static rollover threshold of 0.4 g or better.
Dynamic load transfer ratio	When a vehicle in the loaded condition negotiates an obstacle avoidance, or lane change manoeuvre at highway speeds, the load transfer ratio should not exceed 0.60.
Friction demand in a tight turn	When a vehicle negotiates a 90° turn with an outside radius of 11 m, the peak required coefficient of friction of the highway surface to avoid loss of traction by the tractor drive tires should not exceed 0.1.
Braking efficiency	Vehicles in the loaded or unloaded condition should exhibit braking efficiencies of 70% or better. Braking efficiency is defined as the percentage of available tyre/road friction limit that can be utilised in an emergency stop of 0.4 g deceleration without incurring wheel lockup.
Low-speed offtracking	When a vehicle negotiates a 90° turn with an outside radius of 11 m, the maximum extent of lateral excursion of the last axle of the vehicle, relative to the path followed by the truck tractor steering axle, should not exceed 6 m.
High-speed offtracking	When a vehicle negotiates a turn with a radius of 393 m at a speed of 100 km/h, the maximum extent of outboard lateral excursion of the last axle of the vehicle, relative to the path followed by the truck tractor steering axle, should not exceed 0.46 m.
Transient high-speed offtracking	When a vehicle negotiates an obstacle avoidance or lane change manoeuvre at highway speeds, the maximum lateral excursion of the rearmost axle of the vehicle, relative to the final lateral path displacement of the steering axle, should not exceed 0.8 m.

2.3.3 Memorandum of Understanding regarding heavy vehicle weights and dimensions

Based on these regulatory principles, the Implementation Planning Committee took a conscious decision to regulate configurations using a prescriptive approach with parameters generally based on the dynamic performance of the configurations, rather than attempting to develop a performance-based system of standards (Billing, 2008). The committee developed detailed specifications for the most common vehicles for inter-provincial highway transportation (RTAC, 1988). The specifications included a drawing, maximum/minimum dimensions and permissible maximum masses for each configuration. Examples of dimension limits for a 5-axle tractor semitrailer and mass limits for an 8-axle B-double combination are given in Figure 2-8 and Figure 2-9, respectively.

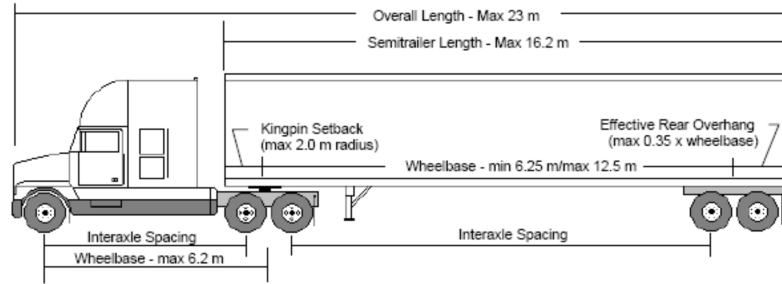

DIMENSION	LIMIT
Overall Length	Maximum 23 m
Overall Width	Maximum 2.6 m
Overall Height	Maximum 4.15 m
Tractor:	
Wheelbase	Maximum 6.2 m
Tandem Axle Spread	Minimum 1.2 m/Maximum 1.85 m
Semitrailer	
Length	Maximum 16.2 m
Wheelbase	
Single, Tandem or Tridem Axle Group	Minimum 6.25 m/Maximum 12.5 m
Kingpin Setback	Maximum 2.0 m radius
Effective Rear Overhang	Maximum 35% of wheelbase
Tandem Axle Spread	Minimum 1.2 m/Maximum 1.85 m
Tridem Axle Spread	Minimum 2.4 m/Maximum 3.7 m
Track Width	Minimum 2.5 m/Maximum 2.6 m
Interaxle Spacings	
Single Axle to Single, Tandem or Tridem Axle	Minimum 3.0 m
Tandem Axle to Tandem Axle	Minimum 5.0 m
Tandem Axle to Tridem Axle	Minimum 5.5 m

Figure 2-8 Permissible dimensions for 5-axle tractor semitrailer (RTAC, 1988)

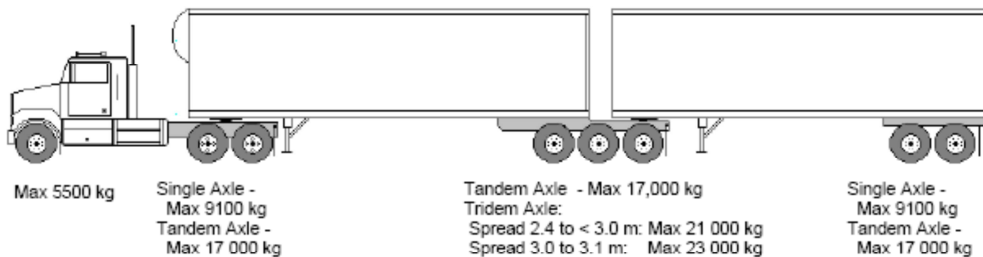

WEIGHT	LIMIT
Axle Weight Limits:	
Steering Axle	Maximum 5500 kg
Single Axle (dual tires)	Maximum 9100 kg
Tandem Axle:	
Axle Spread 1.2 m - 1.85 m	Maximum 17 000 kg
Tridem Axle:	
Axle Spread 2.4 m to less than 3.0 m	Maximum 21 000 kg
Axle Spread 3.0 m to 3.1 m	Maximum 23 000 kg
Gross Vehicle Weight Limits:	
Five Axles	Maximum 40 700 kg
Six Axles	Maximum 48 600 kg
Seven Axles	Maximum 56 500 kg
Eight Axles	Maximum 62 500 kg

Figure 2-9 Permissible masses for 8-axle B-double combination (RTAC, 1988)

The specifications were sufficiently detailed to ensure that pavement, bridge and dynamic performance were all within acceptable limits. The specifications formed part of a Memorandum of Understanding (MoU) on Inter-provincial Heavy Vehicle Weights and Dimensions (RTAC, 1988), which was concluded in 1988 at the meeting of the Council of Ministers Responsible for Highway Safety. The MoU did not require that all provinces adopt it as their only form of regulation, but that the vehicle configurations it defined, with their mass and dimensional restrictions, be allowed to operate in all provinces on a highway network defined by each province.

The MoU was developed with recommendations for a semitrailer length of 16.2 m and an overall length for a B-double combination of 25 m. However, as a result of public opposition in Ontario to these increased lengths, and following consultations, a political decision was taken not to increase the current lengths of 14.65 m for a semitrailer and 23 m for a B-double combination. The other provinces agreed to support this decision. During the following 12 years, on the basis of the results of a number of studies (Good *et al.*, 1991; RTAC, 1992; cited in NCHRP, 2008) and consultations, the various provinces decided to adopt the increased lengths as originally proposed in the MoU.

2.3.4 Further developments since the Memorandum of Understanding

The initial MoU that was adopted in 1988 produced specifications (maximum and minimum dimensions and permissible masses) for the most common vehicle configurations operating inter-provincially in Canada. These limits were derived from dynamic performance measures and target performance levels identified during the Vehicle Weights and Dimensions research project. However, each province had a range of other vehicle configurations that were commonly in use. The question was asked: How should these vehicle combinations be configured to ensure that they meet the same objective standards for dynamic performance as the configurations addressed by the MoU? Thus followed a number of studies to evaluate various vehicle configurations and components such as straight trucks and truck-trailer combinations (Billing and Lam, 1992; Billing *et al.*, 1989), rigid liftable axles (Billing and Patten, 2003; Billing and Patten, 2004), the C-dolly and its hitches (Woodrooffe *et al.*, 1986a; CMVSS, 2007a; CMVSS, 2007b), the quad semitrailer (Nix *et al.*, 1996; Agarwal *et al.*, 1997), semitrailers with self-steering axles (Corbin *et al.*, 1995) and vehicle combinations with a tridem drive tractor (Parker *et al.*, 1998). This approach has also been applied to vehicle configurations that are very different to those defined in the MoU, such as the log truck fleets in Alberta and British Columbia. The forestry industry underwent a process to evaluate the performance of a range of existing and proposed configurations (FERIC, 1998). Vehicles with poor performance were either transitioned out of the fleet, or the configuration was modified to

improve its performance. Subsequently, a range of new vehicle configurations was developed. Some of these configurations operate at combination masses considerably higher than the prevailing legal limits by special permit during the winter.

This approach has continued to be used by all provinces as part of the assessment of vehicle configurations proposed either for regulation or operation under a special permit. The provinces have different approaches to the process for approval, but the underlying assessment has remained consistent with that used for the MoU for the past 20 years. There has been no demand for a performance-based standards approach nor has there been a demand for further increases in vehicle mass limits (Billing, 2008).

2.4 Development of performance-based standards for heavy vehicles in Australia

Heavy vehicles in Australia are regulated by prescriptive standards that have been developed over a long period, largely through empirical approaches (Peters and Stevenson, 2000). The National Transport Commission (NTC), formerly the National Road Transport Commission (NRTC), was established to achieve uniformity in road (and subsequently rail) regulations between all the States and Territories. The preferred approach of the NTC is to harmonise transport regulations through a performance-based regulatory environment (Moore, 2007). The heavy vehicle PBS project is the largest and most advanced of various reform projects being developed by the NTC on a performance basis (Rolland *et al.*, 2006). During the period 1990 to 2000 there was a 50% reduction in heavy vehicle accidents and a 25% improvement in productivity. During the same period heavy vehicle road use in Australia increased by 53% and is expected to grow by another 100% by 2015 (Peters and Stevenson, 2000; NRTC, 2002d).

For several decades a number of States in Australia have permitted heavy vehicles (for example 'road trains'), which do not comply with the prescriptive standards, to operate on parts of the road network. However, this segment of heavy vehicle operations reached a stage where the need for a national uniform approach was identified.

2.4.1 PBS initiative in Australia

In 1999 the NRTC embarked on a process to develop a framework for introducing a performance-based approach for heavy vehicle regulation (Sweatman *et al.*, 1998; Borbely *et al.*, 2000; NRTC, 2000a; NRTC, 2001a). Initially four phases were identified (NRTC, 2000c) but at a later stage two additional phases were added, as shown in Table 2-2 (Rolland *et al.*, 2006). An overview of these phases is presented in the following sub-sections.

Table 2-2 Phases of the PBS initiative in Australia (Rolland *et al.*, 2006)

Phase	Phase objectives
A: Performance measures and standards	Identify appropriate performance measures and standards and evaluate the performance of the existing heavy vehicle fleet.
B: Regulatory and compliance processes	Establish a regulatory system in which PBS can operate as a seamless national alternative to existing prescriptive regulations.
C: Guidelines	Prepare guidelines detailing the procedures and processes for the consistent application of PBS.
D: Legislation	Develop legislative arrangements for PBS to operate as an alternative to prescriptive regulations.
E: Case studies	Assemble work previously conducted and demonstrate the practical application of PBS to nationally agreed priorities.
F: Implementation	Put in place the necessary legislative and administrative systems to allow PBS to operate nationally and provide the training and information to support these changes.

2.4.2 Performance measures and standards (Phase A)

A number of studies (Woodroffe *et al.*, 1998; NRTC, 1999a; NRTC, 2000b; NRTC, 2001b; NRTC, 2001c) were commissioned by the NRTC to establish the minimum required performance measures to ensure acceptable levels of safety and infrastructure protection. Initially, 97 potential measures were identified and were structured into a number of groups including safety, infrastructure, productivity and environmental impact. Through a rigorous process of design, assessment, consultation and independent review, 16 safety and four infrastructure performance standards were developed (Vuong *et al.*, 2002; NRTC, 2003b; NRTC, 2003c; NRTC, 2003d; Pearson and Leyden, 2004; Moore, 2007; NTC, 2008a). The safety and infrastructure performance measures and levels are given in Table 2-3 and Table 2-4 respectively (Edgar, 2004; NTC, 2008a). More detailed definitions of the standards are given in ARTSA (2003) and NTC (2008a).

Further work was carried out to determine the mass and dimension characteristics of the existing Australian heavy vehicle fleet (NRTC, 2001d) and then to assess the performance of the fleet in terms of the proposed standards (NRTC, 2002c).

In order to optimise the existing road network in terms of the types of heavy vehicles that can be operated on various parts of the network, four road types were defined (Levels 1 to 4). Where appropriate, different performance levels are specified for each of the four levels (see Table 2-3). Road authorities are in the process of using the PBS Network Classification Guidelines (NTC, 2007a) to classify their road networks into the four levels.

Table 2-3 Safety standards and performance levels for PBS vehicles in Australia (NTC, 2008a). Definitions of terms are described by ARTSA (2003)

Performance measure	Performance level			
	Road Class			
	L1	L2	L3	L4
Startability (% slope)	≥ 15%	≥ 12%	≥ 10%	≥ 5%
Gradeability A (% slope) (maintain forward motion on grade)	≥ 20%	≥ 15%	≥ 12%	≥ 8%
Gradeability B (minimum speed on 1% grade)	≥ 80 km/h	≥ 70 km/h	≥ 70 km/h	≥ 60 km/h
Acceleration capability	≤ 20.0 s	≤ 23.0 s	≤ 26.0 s	≤ 29.0 s
Overtaking provision	Requirements moved to the Network Classification Guidelines (NTC, 2007a). NTC 2008a gives vehicle length limits for various access classes.			
Tracking ability on a straight path	≤ 2.9 m	≤ 3.0 m	≤ 3.1 m	≤ 3.3 m
Ride quality (driver comfort)	Yet to be defined			
Low-speed swept path width	≤ 7.4 m	≤ 8.7 m	≤ 10.6 m	≤ 13.7 m
Frontal swing: Rigid trucks, truck tractors and buses	Trucks and truck tractors: ≤ 0.7 m; Buses: ≤ 1.5 m			
Frontal swing: Semi-trailers	Maximum of difference (MoD): ≤ 0.4 m Difference of maxima (DoM): ≤ 0.2 m			
Tail swing	≤ 0.3 m	≤ 0.35 m	≤ 0.35 m	≤ 0.5 m
Steer-tyre friction demand	≤ 80% of the max. available tyre/road friction limit			
Static rollover threshold	≥ 0.35 g (≥ 0.40 g for road tankers and buses)			
Rearward amplification	≤ 5.7 SRT of rearmost unit or roll-coupled set of units			
High-speed transient offtracking	≤ 0.6 m	≤ 0.8 m	≤ 1.0 m	≤ 1.2 m
Yaw damping coefficient	≥ 0.15			
Handling quality (understeer/oversteer)	Yet to be defined			
Directional stability under braking	Vehicle must comply with requirements of the TASP standard under specified average decelerations from 60 km/h for various vehicle configurations.			

Table 2-4 Infrastructure standards for PBS vehicles in Australia (NTC, 2008a)

Performance measure	Performance level
Pavement vertical loading	Currently based on prescriptive regulations for axle unit and vehicle loads.
Pavement horizontal loading	Requirements relate to: axle spacing and steering axles for axle units; distribution of tractive force and maximum masses (dependent on road class) for drive axle units.
Tyre contact pressure distribution	Currently based on prescriptive requirements relating to minimum tyre width and maximum tyre pressure.
Bridge loading	Requirements are given for 3 tiers. Tier 1 requires compliance with various bridge formulae; Tiers 2 and 3 require bridge assessments by a qualified bridge engineer or road authority engineer.

2.4.3 Regulatory and compliance processes (Phase B)

Various processes were developed to provide a framework for a national alternative to the prescriptive regulations (NRTC, 2000c; NRTC, 2002a; NRTC, 2003a; NTC, 2005a). These processes include the following steps, which are required to operate a PBS vehicle:

- (a) application,
- (b) assessment of application by an accredited performance assessor,
- (c) draft approval,
- (d) verification of the vehicle after manufacture/modification, and certification of the operator, as having systems in place to ensure on-going compliance with the PBS conditions,
- (e) possible field testing,
- (f) initial monitoring to ensure that actual performance matches expectations,
- (g) final approval based on outcomes of monitoring period,
- (h) addition to national PBS database, and
- (i) operation of PBS-approved vehicle in accordance with conditions of approval.

2.4.4 Guidelines (Phase C)

Various documents (technical and administrative guidelines, codes and rules) were developed to assist those involved in the PBS process and to ensure a consistent application of PBS as follows (Rolland *et al.*, 2006):

- (a) standards and vehicle assessment rules (NTC, 2005b; NTC, 2008a),
- (b) network classification guidelines (NRTC, 2004a; NTC, 2007a),
- (c) PBS assessor accreditation rules (NTC, 2007b),
- (d) vehicle assurance and operating rules (NTC, 2006a),
- (e) vehicle certification rules (NTC, 2007c),
- (f) guidelines for determining national operating conditions (NTC, 2007d),
- (g) Review Panel business rules (NTC, 2007e),
- (h) operator certification guidelines (NTC, 2006b),
- (i) compliance assurance guidelines (NTC, 2006c; NTC, 2006d), and
- (j) enforcement guidelines.

The rules for assessment of PBS vehicles specify in detail how a vehicle assessment, either by field testing or computer modelling, should be undertaken. Differences in approach with computer modelling can produce different results (NRTC, 2001e), hence a detailed specification is required to ensure consistency in modelling results. In addition, an accreditation system was

developed for PBS assessors to further ensure uniformity and an acceptable standard of assessments (Baas *et al.*, 2002; NTC, 2007b).

2.4.5 Legislation (Phase D)

Phase D of the PBS initiative involved the development of new legislation. The purpose of the legislation is threefold:

- To support the establishment and on-going operating authority of the PBS approval body.
- To support institutional arrangements to give effect to PBS approvals on a national basis.
- To enable the application of enforcement and compliance systems.

The development of the PBS legislation follows the Compliance and Enforcement Bill that has extended the responsibility of goods transport to the consignor and/or consignee – the ‘chain of responsibility’ accountability structure – for a range of road traffic offences (NRTC, 2003e; NRTC, 2003f; McIntyre and Moore, 2002; McIntyre, 2005). By linking into this regulatory structure, the amount of new legislation to support PBS has been reduced.

2.4.6 Case studies (Phase E)

Since the commencement of the PBS initiative in Australia, various PBS case studies have monitored and evaluated the benefits of the PBS approach to heavy vehicle regulation (NRTC, 1999b; NTC, 2008b). Various state road authorities have used the PBS standards, as they have become available, as a basis for issuing permits for abnormal vehicles such as road trains and for assessing innovative vehicles. Many of these were approved as case studies and were used by the NTC to demonstrate the potential safety and productivity benefits of PBS (NRTC, 2002b; Coleman *et al.*, 2003; Di Cristoforo *et al.*, 2003; Sweatman *et al.*, 2003a; Sweatman *et al.*, 2003b; Di Cristoforo, 2004; Prem *et al.*, 2006a; Prem *et al.*, 2006b; Johnston and Bruzsa, 2008; Prem *et al.*, 2008).

2.4.7 Implementation (Phase F)

The first step in Phase F was the establishment of an Interim Review Panel (IRP) whose function was to assess PBS applications in terms of the Rules for Assessment (NTC, 2005b; NTC, 2008a). Of the initial eight applications to the IRP, only one was found to comply with the complete set of safety standards. As a result of these initial assessments, members of the IRP requested the NTC to review several of the approved performance standards.

During 2007, the IRP was replaced with a permanent Review Panel, whose main functions are as follows (NTC, 2007e):

- Determine whether or not a vehicle meets the PBS requirements.
- If necessary, specify special conditions under which a PBS vehicles is to operate.
- Maintain a database for tracking PBS applications and approvals.
- Accredite vehicle certifiers on the basis of recommendations of the States and Territories.
- Accredite and audit third party assessors.
- Facilitate a mapping platform for the national road network.

2.4.8 Intelligent Access Programme

The Intelligent Access Programme (IAP) is an initiative in Australia that enables the remote monitoring of heavy vehicles to ensure that they adhere to certain agreed operating conditions (Baring and Koniditsiotis, 2008; Koniditsiotis and Karl, 2010). Monitoring is done through in-vehicle systems that utilise sensors to monitor parameters such as position, time, speed, and axle unit masses, and wireless communication networks to transmit data (Austroads, 2004a; Austroads, 2004b). Queensland Transport is leading the initiative in Australia to include the IAP as a condition for operating certain PBS vehicles, which represents a fundamental shift in the management of heavy vehicles in Australia (Brusza *et al.*, 2008). Vehicles are fitted with a GPS tracking system and an on-board monitoring system, and their operation is monitored by a third party service provider (vehicle tracking company) who makes the data available to the relevant stakeholders. Service providers are also responsible for reporting to the road authorities any non-compliance events such as time and route restrictions, maximum speed and maximum mass.

2.4.9 National Heavy Vehicle Regulator

In July 2009, the Council of Australian Governments (COAG) agreed to establish a single national system of laws for heavy vehicles greater than 4.5 tons. The National Heavy Vehicle Regulator (NHVR) started operations in January 2013 with its head office in Brisbane, Queensland. Initially, the NHVR is managing accreditations in terms of the National Heavy Vehicle Accreditation Scheme (NHVAS) and design and vehicle approvals on a national basis for the PBS scheme (NHVR, 2013). During the period February to September 2013, The NHVR issued more than 320 PBS approvals, representing over 500 combinations (Brusza, 2013).

2.4.10 Conclusions

The approach adopted in Australia for the design, manufacture and operation of PBS vehicles is more comprehensive and generic than the approaches in Canada and New Zealand. Provision is made in legislation for any transport operator to develop an innovative heavy vehicle design and

operate the vehicle on the whole or a subset of the road network on condition that it meets all the specified requirements.

2.5 Discussion and conclusions

In terms of the different approaches to regulating heavy vehicles on the road network described in this chapter, three countries, *viz.* Australia, Canada and New Zealand, have implemented a PBS approach in various ways.

In New Zealand, a problem with heavy vehicle crashes, *i.e.* rollovers, was identified and, subsequent to in-depth research, one performance standard (SRT) was included in the Vehicle Mass and Dimension rule. As from 1 July 2002 all trucks with a mass greater than 10 tons had to comply with this new rule. The SRT calculator was developed to assist operators with the assessment of their vehicles. Although only one performance standard was incorporated into the legislation, the impact was positive – the SRT for new timber trailers is typically 0.42 g compared with less than 0.35 g for timber trailers before the SRT limit was introduced, and the rate of rollover crashes has continued to decrease. The advantage of this approach is that it is relatively simple and focussed. One or more additional performance standards could be incorporated into the legislation at a future date should a need be identified. Such an approach could be considered in South Africa to address problems in the existing heavy vehicle fleet. However, as in the case of New Zealand, sufficient data should be collected and analysed in order to assess the nature of the problem. Data should include causes of heavy vehicle crashes, and the performance standards of the existing fleet (in particular those of heavy vehicles that are involved in crashes). Unfortunately, in South Africa, these data are not readily available.

The Canadian approach was to introduce performance-based prescriptive regulations (based on seven performance measures) through the MoU of 1988, applicable to certain vehicle configurations. The MoU required that vehicles complying with these regulations be allowed to operate in all provinces on routes defined by each province. Subsequent to the implementation of the MoU, other vehicle configurations have been assessed using the same PBS approach. If compliant, such vehicle configurations have been allowed to operate on parts of the road network. The advantage of this approach is that the performance-based prescriptive regulations are simple to enforce on-road. However, each time an operator wishes to use a vehicle configuration that has not been previously approved, new assessments must be carried out. In the South African context, this approach could address about 80% of the existing heavy vehicle fleet that operate primarily on the rural road network if assessments were limited to five- and six-axle articulated and seven-axle B-doubles (interlinks).

Australia has adopted a holistic PBS approach for heavy vehicles. Because it is the most generic approach, it probably has the greatest potential for significant safety and productivity gains. However, the implementation of such a system is a massive (and costly) task, and could be too daunting for many transport operators. In addition, the classification of the entire network into the identified four levels is a costly and time-consuming exercise. Changes in the geometrics of the network due to upgrading will also require that the Road Classification System be upgraded periodically.

The use of the approach embodied in the Intelligent Access Programme supports the self-regulation philosophy, allowing all parties in the value logistic chain as well as the road authority and enforcement agency to monitor certain parameters of the heavy vehicle operation at any time as opposed to relying solely on on-road enforcement. Such an approach would have significant merit in South Africa where non-compliance with road traffic regulations is widespread, law enforcement is inadequate and the justice system is not sufficiently punitive with regard to traffic violations due to under-capacity problems (Killian *et al.*, 2008; Nordengen, 1998; Nordengen and Hellens, 1995).

The potential benefits of a PBS approach in terms of vehicle safety; road infrastructure wear; productivity; and vehicle emissions have been highlighted in all three countries described in this literature review as well as by the OECD report on performance-based standards for the road sector (OECD, 2005). The current road freight environment in South Africa is one that features significant growth in heavy vehicle volumes, increasing global competitiveness, increases in fuel prices, traffic congestion, CO₂ emissions and high vehicle crash and road fatality rates. Taking this into account, consideration should be given to the development and implementation of a PBS approach in South Africa. Such an approach could be made applicable to the existing heavy vehicle fleet (or a portion thereof), a new category of PBS vehicles, abnormal load vehicles or a combination of the above.

3 DEVELOPMENT OF A PBS PROJECT FRAMEWORK FOR SOUTH AFRICA

A component of the research work for this thesis involved the development of a framework for the PBS demonstration project in South Africa. Section 3.1 provides a background to the development of the PBS demonstration project. This includes the requirement of PBS operators being certified in terms of the Road Transport Management System (RTMS) accreditation scheme, the establishment of a national PBS committee and Review Panel, general operational requirements for PBS demonstration vehicles and the development of a national PBS strategy. Sections 3.2 and 3.3 describe requirements regarding the PBS safety and infrastructure performance standards respectively. Section 3.4 provides an overview of the rules for participation in the PBS demonstration project. Section 3.5 provides information regarding a number of the PBS demonstration vehicles, some of which have been approved and are operational and others of which were in the approval or design phase as at November 2013.

3.1 Background

The introduction of PBS for heavy vehicles in South Africa was first identified in the National Overload Control Strategy (Steyn *et al.*, 2004) as a potential concession of a proposed self-regulation initiative. In order to investigate and evaluate the potential benefits of a PBS approach to the design and operation of heavy vehicles in South Africa, a PBS research programme was initiated at the CSIR Built Environment. Parliamentary Grant (PG) funding from the Department of Science and Technology was obtained through the CSIR PG Project approval process. Initial funding for the project commenced in the 2006/07 financial year. A PBS steering committee was established and held its first meeting on 24 August 2004 at the Institute for Commercial Forestry Research (ICFR) in Pietermaritzburg. Committee members included representatives from the CSIR, the national Department of Transport, the KwaZulu-Natal Department of Transport, the ICFR, the National Productivity Institute (NPI, now Productivity SA), Institute of Road Transport Engineers (IRTE), Forest Engineering South Africa, Mondi Business Paper (Mondi) and Sappi Forests (Pty) Ltd (Sappi). The South African National Roads Agency Limited (SANRAL) joined the steering committee in 2007 and representatives of the universities of KwaZulu-Natal and Witwatersrand joined the committee in July 2006 and May 2010 respectively. The author, representing the CSIR, has served as chairman of this committee since its establishment. As part of the PBS research programme, a need was identified to design, manufacture and operate a number of PBS demonstration projects in South Africa in order to gain practical experience in the performance-based standards

approach to heavy vehicle design and operations and to quantify and evaluate the potential safety and productivity benefits of this approach for road freight transport.

Initial considerations for the PBS research programme and demonstration project that were raised at the initial meetings of the PBS steering committee included:

- Certification in terms of the RTMS accreditation scheme as a prerequisite for participation in the project.
- Adoption of the Australian PBS scheme for the purpose of the demonstration project in South Africa.
- Use of NTC-certified PBS assessors in Australia.
- Development of PBS assessment capability in South Africa.
- Operation of PBS demonstration vehicles under the provisions of Section 81 of the National Road Traffic Act (DoT, 2003) through the issuing of Abnormal Load permits.
- Retention of selected prescriptive heavy vehicle mass and dimensional limitations for the demonstration project.
- Development of a national PBS strategy for South Africa.
- Obtaining official support of the programme from the Minister of Transport.
- Use of Gerotek Facilities near Pretoria for validating computerised PBS assessments through field testing.

3.1.1 The Road Transport Management System (RTMS)

The RTMS is an industry-led, voluntary self-regulation scheme that encourages consignees, consignors and transport operators engaged in the road logistics value chain to implement a vehicle management system that promotes the preservation of the road infrastructure, the improvement of road safety and an increase in the productivity of the logistics value chain (National Productivity Institute, 2006; Nordengen and Oberholzer, 2006). This scheme also supports the Department of Transport's National Freight Logistics Strategy (DoT, 2005).

Because of the higher risk associated with operating longer and/or heavier vehicles on the public road network, transport operators that participate in the PBS demonstration project are required to have their fleet, of which their PBS vehicles are a part, certified in terms of the RTMS standard for transport operators (Standards South Africa, 2007). The internal benefits of RTMS certification in terms of a number of indicators including crash rate, overloading, fuel efficiency, tyre wear and speeding offences have been observed by a number of operators that have participated in the RTMS scheme since 2006 (RTMS, 2012).

3.1.2 PBS committee structures

The objective of the PBS steering committee was to promote, implement and evaluate PBS demonstration projects in South Africa. Initially, besides members representing national and provincial government, the NPI, the IRTE, the CSIR and consignors/consignees in the forestry industry (Sappi and Mondi), transport operators, OEMs and trailer manufacturers that were involved in the initial two pilot projects were also included on the committee. However, as the number of demonstration projects increased, the committee decided in February 2010 that, for commercial reasons, the OEMs, trailer manufacturers and transport operators should be excluded from the committee. This decision took effect in August 2010.

In December 2009, the committee decided to establish a sub-committee, the PBS Review Panel (following the Australian PBS structure), with the main purpose of reviewing and approving PBS applications. The Review Panel consists of members representing the CSIR, universities of KwaZulu-Natal and Witwatersrand, national DoT, SANRAL and the provinces of KwaZulu-Natal, Eastern Cape, Limpopo and Mpumalanga. Because of limited PBS applications at the time, the first meeting of the Review Panel only took place on 5 October 2010.

In an effort to more effectively communicate the objectives of the PBS project to various stakeholders and to the public at large, the PBS steering committee decided at a committee meeting on 19 August 2010 to introduce the term “Smart Truck” to refer to the PBS project, the PBS demonstration vehicles, the steering committee and the Review Panel. The term “PBS” is still used widely, particularly when referring to vehicle assessments and in more technical discussions and meetings.

3.1.3 Operation requirements for PBS demonstration vehicles on the South African road network

Vehicles that do not comply with the National Road Traffic Regulations (NRTR) (DoT, 2013) are required to be issued with an abnormal load permit in terms of Section 81 of the National Road Traffic Act (DoT, 2003). Such permits are generally reserved for the movement of indivisible loads, which, when transported by road, exceed permissible maximum masses and/or dimensions as prescribed in the NRTR. Abnormal load permits are issued on a provincial basis, although countrywide permits can be issued by a single province for smaller dimensional abnormal loads that do not exceed any mass limitations. PBS demonstration vehicles that exceed permissible maximum masses or dimensions are required to be issued with an abnormal load permit by the relevant province(s).

The Abnormal Loads Technical Committee (ALTC) is chaired by the national Department of Transport and has representation from the nine provinces in South Africa and the CSIR. The

committee meets bi-annually with the main purpose of dealing with issues relating to abnormal loads and as far as possible maintaining a uniform abnormal load policy throughout the country. Guidelines for the conditions under which abnormal load permits are issued are given in the TRH11: Dimensional and mass limitations and other requirements for abnormal load vehicles (DoT, 2010). An ALTC Working Group meets between the ALTC meetings to discuss issues of a technical nature and to make recommendations to the ALTC for approval.

Since the commencement of the PBS initiative, the ALTC has been kept informed of the PBS projects through feedback at the ALTC and ALTC Working Group meetings. The level of support of the PBS initiative by the provincial abnormal load permit offices and the manner in which PBS applications are treated has varied considerably. Abnormal load permits for PBS vehicles are generally issued on an annual basis; however in some cases, permits are issued for shorter periods.

3.1.4 PBS strategy

One of the first tasks identified by the PBS steering committee was to develop a PBS strategy for South Africa. An initial draft was circulated to various stakeholders in January 2005. The final version of the strategy (version 7) was completed in June 2007 (CSIR, 2007), some eight months before the first two PBS vehicles were commissioned.

The strategy addresses a number of issues including:

- (a) PBS committee structure,
- (b) support from Government and other stakeholders,
- (c) PBS demonstration projects,
- (d) PBS framework, which included the following:
 - (i) technical evaluation and approval of designs
 - (ii) road network classification
 - (iii) operations and control/monitoring
 - (iv) develop/evaluate standards
 - (v) develop legislative framework
 - (vi) application and assessment guidelines
 - (vii) SA heavy vehicle fleet characterisation
- (e) project reporting and feedback,
- (f) PBS research programme,
- (g) funding, and
- (h) marketing and awareness.

Two of the primary purposes of the strategy were to set guidelines for engaging key stakeholders in government and the private sector and for the development of a PBS demonstration project.

3.2 Safety performance standards

For the purpose of the PBS demonstration project in South Africa, it was decided to make use of international heavy vehicle PBS research, development and implementation. After reviewing the PBS initiatives in Australia, Canada and New Zealand (see Chapter 2), the Australian PBS scheme (NTC, 2008a) was selected as the basis for the South African PBS project. It was recognised that if this scheme was adopted by the South African Department of Transport in the long term, it would need to be adapted to accommodate South African-specific conditions *e.g.* maximum vehicle width is 2.5 m in Australia and is 2.6 m in South Africa.

After consideration of both the safety and infrastructure performance standards contained in the Australian PBS scheme, it was decided that only the safety performance standards would be used; infrastructure performance standards would be developed based on existing approaches in South Africa for pavement and bridge design and assessment. The safety performance standards that were adopted were thus (see Table 2-3):

- (a) Startability,
- (b) Gradeability (A and B),
- (c) Acceleration capability,
- (d) Tracking Ability on a Straight Path,
- (e) Low Speed Swept Path,
- (f) Frontal Swing,
- (g) Tail Swing,
- (h) Steer Tyre Friction Demand,
- (i) Static Rollover Threshold,
- (j) Rearward Amplification,
- (k) High Speed Transient Offtracking,
- (l) Yaw Damping Coefficient, and
- (m) Directional Stability under Braking

Details of the infrastructure standards for pavements and road structures are discussed in Section 3.3.

3.2.1 PBS assessors

During the planning stages of the first two PBS demonstration vehicles in South Africa it was recognised that the most effective approach to carrying out the initial PBS assessments would be to engage Australian NTC-accredited PBS assessors. Contact had previously been made with two of the PBS assessors, Mechanical System Dynamics (MSD) and ARRB Group as a result of participation in a PBS seminar in Melbourne in 2003, a forestry industry study visit to Australia in 2004 and a Road Freight Association study tour in 2005. Organisations such as the NRTC, VicRoads, Queensland Transport, MSD and ARRB Group provided valuable information and guidance regarding the development and implementation of both self-regulatory and PBS schemes for heavy vehicles in South Africa. MSD and ARRB Group were appointed by Sappi and Mondi respectively to conduct PBS assessments on the first two PBS concept vehicle designs.

The PBS committee identified the need to develop PBS assessment capability in South Africa and thus approached a number of universities (Engineering Departments), the Council for Scientific and Industrial Research (CSIR) and private consulting firms with a view to becoming involved in the project. During the past five years three students at the University of KwaZulu-Natal (UKZN) and the University of Witwatersrand (Wits) have completed PBS-related MSc (Eng) degrees (Thorogood, 2009; De Saxe, 2012; Sharma, 2013) and more than 25 Mechanical Engineering final year design or research projects have been submitted related to heavy vehicle dynamics or PBS for heavy vehicles.

As part of an initiative to stimulate interest in and develop an understanding of the PBS approach to heavy vehicle design and heavy vehicle dynamics in general in South Africa, the CSIR in conjunction with Wits and the South African Road Federation organised the presentation of a University of Michigan Transport Research Institute (UMTRI) four-day course “Mechanics of Heavy-Duty Truck Systems” in Stellenbosch (April 2009) and in Johannesburg (April 2011). The two courses were attended by a total of 58 delegates. A third course is planned for 2014.

In October 2012, the Smart Truck Review Panel agreed that, for the purposes of the PBS demonstration project, potential PBS assessors in South Africa would be required to have three of their own PBS assessments validated by an NTC-accredited assessor in order to be recognised as an accredited PBS assessor in South Africa. A list of NTC-assessors is available on the Australian National Heavy Vehicle Regulator website under the PBS section (<https://www.nhvr.gov.au/road-access/performance-based-standards/pbs-useful-contacts>). By November 2013, one PBS assessor had been accredited by the Review Panel and another PBS assessor was in the process of having three PBS assessments validated by Australian NTC-

accredited PBS assessors. Should the PBS approach be officially adopted in South Africa, a more formal accreditation process will be developed.

3.3 Infrastructure performance standards

3.3.1 Mass and dimensional limitations for PBS demonstration vehicles

For the PBS demonstration project, non-compliance with the NRTR is generally limited to overall vehicle combination length and Permissible Maximum Combination Mass (PMCM). All PBS demonstration vehicles are required to comply with axle and axle unit load limits for steering and non-steering axles and for axles fitted with single and dual tyres as specified in Regulations 238, 239 and 240 of the NRTR (DoT, 2013). Generally this means that a tandem axle unit with dual tyres (a typical drive axle unit) is limited to 18 tons and a tridem axle unit with either single or dual tyres is limited to 24 tons. Single non-steering axles are limited to 8 tons (single tyres) and 9 tons (dual tyres). Steering axles are limited to a maximum mass of 7.7 tons, but in most cases either the vehicle manufacture's rating or tyre manufacture's rating is the limiting factor.

Besides being limited to the sum of the permissible maximum masses of the axles and axle units, the permissible maximum mass of a combination of vehicles is limited to 56 tons in terms of Regulation 237 of the NRTR (DoT, 2013). This limit is generally relaxed for most PBS demonstration vehicles.

3.3.2 Road pavements

As indicated in Section 3.2, the infrastructure performance standards for the PBS demonstration project are based on South African pavement and bridge design loading approaches. For road pavements, the current South African Mechanistic-Empirical Design and Analysis Methodology (SAMDM) (Theyse *et al*, 1996), which is the basis of the South African pavement design manual for flexible pavements, TRH4 (DoT, 1996), is used to assess the relative road wear of the proposed PBS vehicle combination and a representative baseline vehicle. The baseline vehicle is usually the vehicle that is being used in the transport operation for which the proposed PBS vehicle is intended to replace. The requirement for PBS demonstration vehicles is that the road wear per ton of payload of the PBS vehicle must be less than the equivalent road wear of the baseline vehicle. As the number of different PBS demonstration vehicles increases, the intention is to develop a set of road wear benchmarks (for different vehicle configuration categories) against which proposed PBS vehicles can be assessed.

The CSIR Pavement Design Software, MePads (mePADS, 2008), is an electronic version of the SAMDM and is currently being used to assess baseline and proposed PBS vehicles. Should the

PBS approach to heavy vehicles be accepted into South African legislation, it is intended that this methodology will be used to develop a pavement infrastructure performance standard for Smart Trucks in South Africa. The software combines a stress-strain computational engine with pavement material models developed in South Africa. Pavement layer life is expressed in terms of the number of repetitions of an axle load until failure. Layer life is based on the typical linear-log damage functions (or “transfer functions”) obtained (and calibrated) from experience and from the results of Heavy Vehicle Simulator (HVS) testing on various pavement types carried out in South Africa since 1975.

The SAMDM approach is used to estimate the Load Equivalency Factors (LEFs) of each vehicle under static loading based on the critical pavement layer life approach (De Beer *et al*, 2008; De Beer *et al*, 2009). The philosophy of “Equivalent Pavement Response - Equivalent Pavement Damage” (EPR-EPD) is used rather than reducing a vehicle to a single Equivalent Standard Wheel Mass (ESWM), or to an Equivalent Standard Axle Load (ESAL). With the EPR-EPD approach, no “fixed equivalencies” are used *per se*, and each vehicle is considered with its full axle/tyre configuration (*i.e.* tyre/axle loading and its associated tyre inflation pressure) as input into the SAMDM and the road wear caused by the freight vehicle is directly estimated for the pavement type under consideration. With the EPR-EPD approach the stresses and strains (*i.e.* mechanistic pavement response parameters) are directly related through the associated transfer functions for pavement damage to layer life and hence “pavement life”. With this approach, the pavement life is considered as being equal to the “critical layer life”, *i.e.* the life of the structural layer with the shortest life in the pavement structure (De Beer *et al.*, 2012).

The pavement life or bearing capacity of the pavement under consideration is also determined under a Standard 80 kN axle with four tyres (two dual sets) at a tyre inflation pressure of 520 kPa. The LEF of the vehicle is calculated as the sum of the ratios (for all axles of a particular vehicle) between the critical layer life of the pavement determined from the Standard 80 kN axle with four tyres (two dual sets) at an inflation pressure of 520 kPa (*i.e.* the bearing capacity of the pavement), divided by the critical layer life under each individual axle load and its associated tyre pressures as follows:

$$LEF_v = \sum_{i=1}^n \frac{N_{critical}(SA)}{N_{critical}(A_i)} \quad (3.1)$$

where:

LEF_v = Load Equivalency Factor of vehicle
 n = Number of axles on vehicle

$N_{critical}(SA)$ = Minimum layer life of pavement under the loading of the Standard axle of 80 kN and 520 kPa inflation pressure on 4 tyres (*i.e.* 20 kN per tyre @ 520 kPa contact stress (= inflation pressure)) [No. of repetitions]

$N_{critical}(A_i)$ = Minimum layer life of pavement under the loading of axle i of vehicle under consideration [No. of repetitions]

This is done for eight typical South Africa pavement design types in both wet and dry conditions (Figure 3-1). LEFs for a wet pavement are typically 50 to 100% more than the same pavement in a dry condition, depending on the pavement type. For the purposes of comparison, and to simplify the presentation of results, an average wear cost is calculated for the 16 cases (8 pavement types, wet and dry conditions) for the baseline and PBS vehicles (Nordengen and Roux, 2013).

3.3.3 Bridge structures

For the purpose of the protection of structures, Regulation 241 of the NRTR limits the concentration of load on any group of axles within a vehicle combination through the formula:

$$P = 2.1 \times L + 18 \quad (3.2)$$

where:

P = permissible mass [ton]

L = distance between the centres of the extreme axles of any group of axles/axle units [m]

At the beginning of 2010, it was decided to apply the more complex, but less conservative “Abnormal Load” bridge formula (ALBF) (DoT, 2010), which is based on South African bridge design loading, NA + NB30 (CSRA, 1981), to PBS vehicles rather than the standard bridge formula that is applicable to all legal heavy vehicles. The adoption of the abnormal load bridge formula for PBS demonstration projects is based on the premise that the PBS vehicles operate in a more controlled environment, including the RTMS self-regulation accreditation requirement, than the general heavy vehicle fleet and this has been shown to be the case (Section 5.2). Hence the risk of non-compliant behaviour including overloading, speeding and reckless driving is considerably reduced. In fact, because of the monitoring requirements of PBS demonstration vehicles (including on-line access to PBS vehicle tracking systems by the relevant road/enforcement authorities), it is likely that the operations involving PBS vehicles are considerably more controlled and compliant than many abnormal load operations.

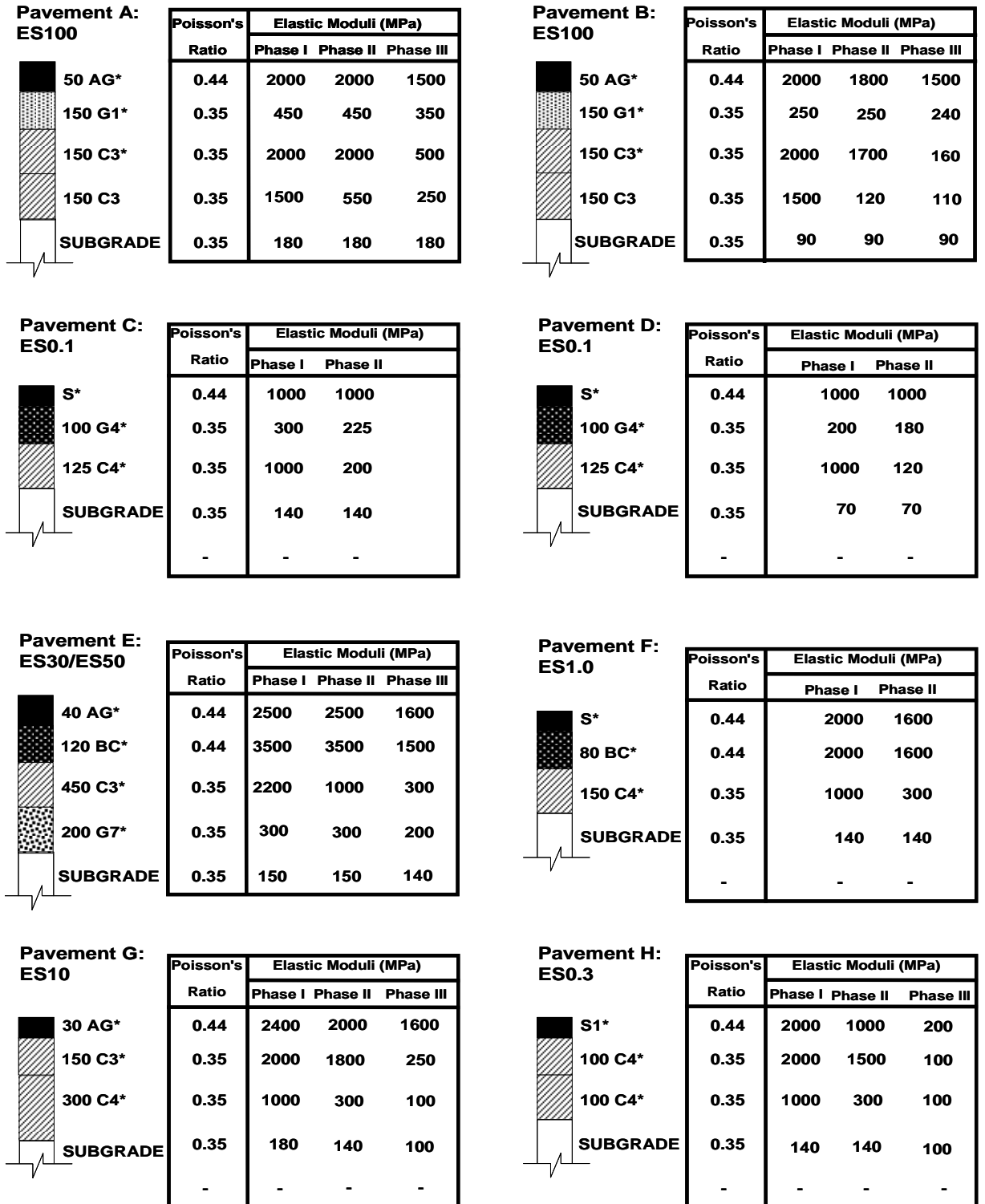

Figure 3-1 Eight flexible road pavement structures and their material properties used for the mechanistic analysis for the PBS road wear comparative analysis. Classification according to TRH14. (CSRA, 1985)

The adoption of the ALBF enabled one of the original PBS vehicles to be shortened by 1.24 m from 27 m to 25.76 m by reducing the length of the trailer drawbar without compromising on the permissible maximum payload. This combination, at 67.5 tons, has a minimum factor of safety of 44.8% in terms of the ALBF. A reassessment of the safety standards showed an improved performance in terms of Tracking Ability on a Straight Path, Low Speed Swept Path, Steer Tyre Friction Demand and Static Rollover Threshold. Although there was a reduced performance in terms of Rearward Amplification (2.8%), High Speed Transient Offtracking (5.6%) and Yaw Damping Coefficient (15%), the modified vehicle combination still meets all the requirements of a Level 2 PBS vehicle.

During 2012, the Smart Truck Review Panel decided to investigate another more fundamental approach for assessing the safety of structures. A computer application that was originally developed for assessing the effect of abnormal load all-terrain mobile cranes on structures (Anderson, 2011), compares maximum bending moments and shear forces generated on a range of span lengths (including two- and three-span continuous structures) by the vehicle being assessed with those of a reference load, in this case the TMH7 NA + NB30 design load. Currently all proposed PBS projects are being assessed in terms of structures using both methods (De Saxe and Roux, 2013a; De Saxe and Roux, 2013b; De Saxe and Roux, 2013c; De Saxe *et al*, 2013; Roux and De Saxe, 2013). It is likely that in the near future the assessment approach comparing maximum bending moments and shear forces will be adopted for the PBS assessment of structures.

3.4 Rules for application to participate

In order to facilitate the participation of transport operators, consignors, consignees and trailer manufacturers in the PBS demonstration project, a set of guidelines was developed providing a step-by-step approach for submitting applications, obtaining approval, design development, assessment and commissioning (Appendix B; CSIR, 2013a). These guidelines cover aspects such as:

- (a) RTMS-certification requirement,
- (b) letter requesting operational approval,
- (c) detail design approval and assessment,
- (d) driver requirements,
- (e) vehicle tracking,
- (f) data monitoring, and
- (g) sanctions.

For the purpose of the PBS demonstration project, PBS assessments of both the baseline and the PBS design vehicles are required. This enables a quantification of the improvement in safety performance of the PBS vehicle compared with the baseline vehicle. It also provides the opportunity to identify design weaknesses of typical vehicles in the South African heavy vehicle fleet.

3.5 PBS demonstration vehicles

This section describes the PBS vehicles that currently form part of the demonstration project in South Africa. Most of the forestry PBS vehicles are operational whereas in the other industries, most were in the planning, design or “awaiting approval” phases in November 2013. Although a number of car-carrier PBS vehicles are operational, these will continue to be restricted to the prescriptive height and length limits until the proposed roadmap for car-carriers in South Africa, which requires all new over-height/over-length car-carriers to be PBS-compliant, is approved by the Abnormal Loads Technical Committee and the national DoT.

Because the majority of the operational PBS vehicles are in the forestry industry, it was decided to limit the performance analyses of the PBS vehicles in this study to the 49 forestry PBS vehicle combinations, representing 28.3 million vehicle kms. The 13 PBS combinations operating in the mining industry represent only two PBS designs and had only covered 1.3 million vehicle kms by September 2013. Statistically, the forestry PBS data allowed a more meaningful analysis.

3.5.1 Forestry

Because the RTMS self-regulation scheme was initiated in the forestry industry, it was identified as the logical industry to commence with PBS demonstration projects. Sappi and Mondi, the two major timber growers and pulp and paper companies in South Africa, decided to initiate PBS demonstration projects, and both companies set up project teams consisting of their selected truck OEM, trailer manufacturer, other suppliers and consultants. Sappi appointed Mechanical System Dynamics Pty Ltd (MSD) and Mondi appointed the Australia Road Research Board (ARRB Group) in Australia to assist with the development and analysis of the PBS vehicles. Both PBS design teams commenced work during the latter half of 2004. Based on the respective Sappi and Mondi PBS designs, operational approval was granted by the KwaZulu-Natal Department of Transport to both companies in January 2006. An overview of the design process of the Sappi PBS demonstration vehicle is given in Nordengen *et al.*, 2008.

The Sappi PBS vehicle has an overall length of 27.0 m and a Permissible Maximum Combination Mass (PMCM) of 67.5 tons. The Mondi PBS vehicle has an overall length of 24.0 m and a PMCM of 64 tons. These PBS vehicles compare with the baseline (legal) vehicle

of similar configuration, which has a maximum overall length of 22.0 m and PMCM of 56 tons. All the axle and axle unit loads of the PBS vehicles comply with the requirements of NRTR. The layout of the baseline and the two PBS vehicles are shown in Figure 3-2 and the PBS vehicles are illustrated in Figures 3-3 and 3-4. The Sappi PBS vehicle commenced operations at the end of November 2007 and the Mondi PBS vehicle in mid-December 2007 (Nordengen, 2009; Nordengen, 2010, Nordengen, 2012).

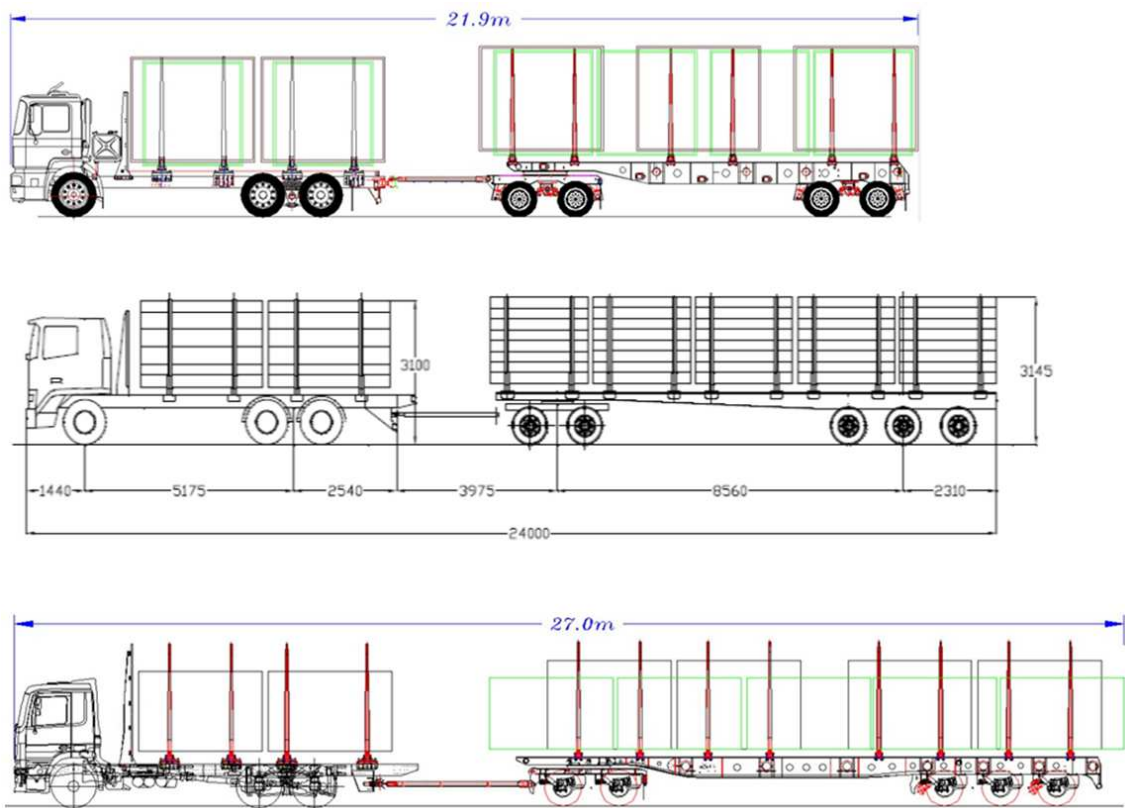

Figure 3-2 Layout of the 22 m baseline (legal) and initial Mondi (24 m) and Sappi (27 m) PBS demonstration vehicles



Figure 3-3 Mondi PBS demonstration vehicle



Figure 3-4 Sappi PBS demonstration vehicle

At the beginning of 2009 the KZN DoT approved 30 additional PBS permits for the forestry industry; 15 permits were allocated to Sappi and 15 permits to Mondi. One of the motivating factors for this decision was the need to accumulate a significant number of vehicle kilometres for the purpose of evaluating safety performance. Fatality rates are typically measured per million vehicle kms; fatality rates associated with heavy vehicles are typically measured per 100 million kms (OECD, 2011). The initial two PBS vehicles were together averaging approximately 41 000 km/month or approximately 492 000 km/annum. Sappi decided to apply for 15 additional permits based on the original PBS design, whereas Mondi decided to develop two new designs. These are shown in Figure 3-5 and Figure 3-6.

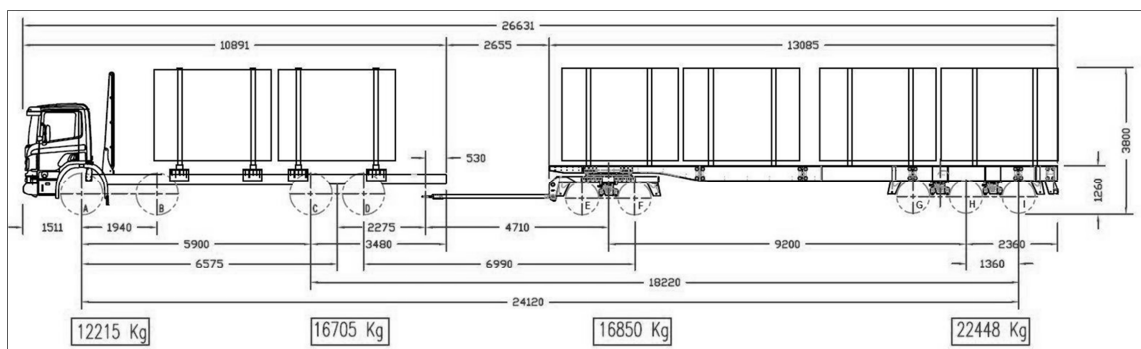

Figure 3-5 Mondi PBS demonstration vehicle Mk II (68.22 tons, 26.63 m)

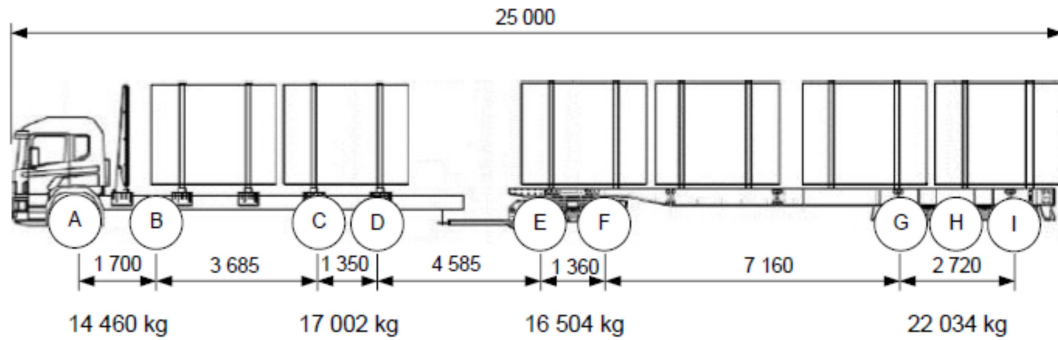

Figure 3-6 Mondi PBS demonstration vehicle Mk III (70 tons, 25.00 m)

As at the end of November 2013, eight different PBS designs, representing 49 operational PBS vehicles, had been approved in the forestry industry. A summary of these projects is given in Table 3-1.

Table 3-1 Operational PBS vehicles in the forestry industry as at November 2013

Date of first commissioning	Transport Operator	No. of vehicles	Overall length (m)	PMCM (ton)
Nov 2007	Timber 24	1	27.00/25.76 ¹	67.5
Dec 2007	Super Group	1	24.00	64.0
Sept 2009	Timber Logistics Services	16	27.00/25.76 ¹	67.5
Oct 2010	Timberology	7	25.00	70.0
Aug 2011	Unitrans timber	7	25.08/24.25 ²	70.0/67.0
Aug 2011	Gaskells	5	25.08	67.0
May 2012	Buhle Betfu	10	25.75	67.5
July 2013	Zabalaza Hauliers	2	22.90	67.5

Notes: ¹ Design change as a result of adoption of the ALBF (Section 3.3.3)

² Two PBS designs

3.5.2 Mining

The second industry to participate in the PBS project was the mining industry. Four road train operations have been in existence in South Africa for some decades, the first of which commenced in the 1980s. The routes on which these road trains operate are either lightly-trafficked provincial roads in remote areas (Western Cape and Northern Cape provinces) or within the property of a mine (Richards Bay Minerals, KwaZulu-Natal province). Applications by various transport operators since 2006 to increase the length and payload of the vehicle combinations were approved on condition that the new vehicle designs complied with the requirements of the PBS demonstration project. Unitrans Mining embarked on three such

demonstration projects, two of which have been operational since October 2011 and January 2013 respectively. The baseline road train at the Richards Bay Minerals mining operation consisted of a truck tractor and three trailers (A-triple) and had a maximum combination mass of 145.1 tons and an overall length of 34.95 m. The PBS road train consists of a truck tractor (tri-drive axle unit) and four trailers (BAB quad) with a maximum combination mass of 185 tons and an overall length of 42.77 m. The baseline and PBS combinations are shown in Figure 3-7.

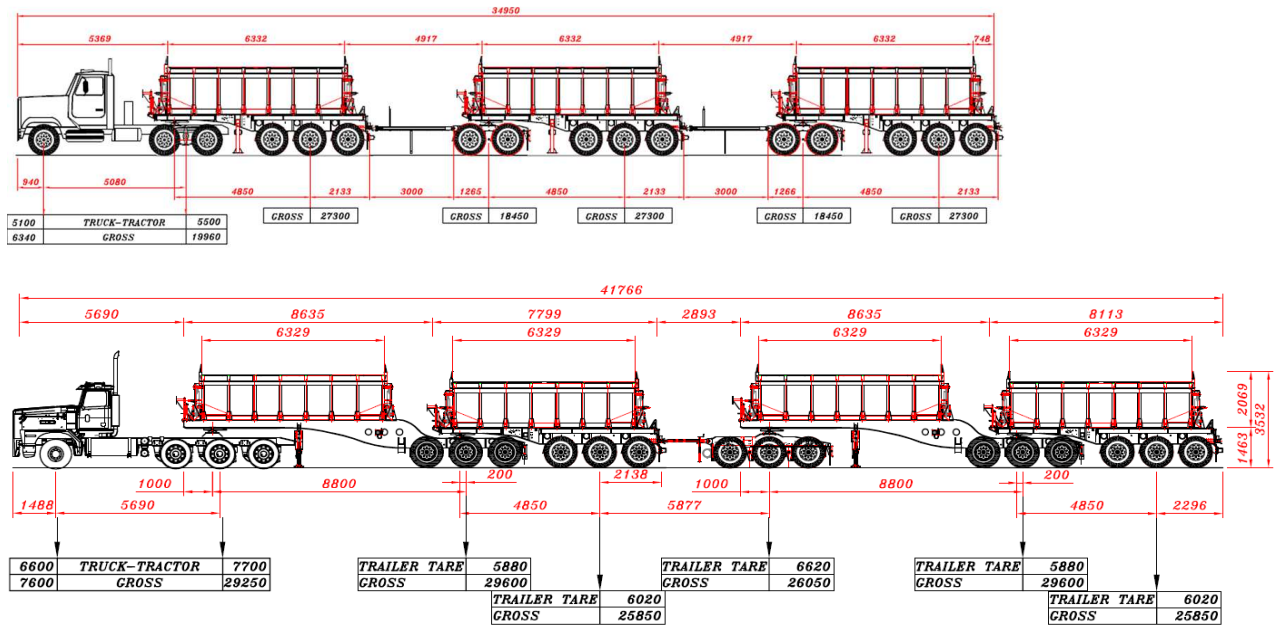

Figure 3-7 Unitrans Mining baseline and PBS road trains (Richards Bay Minerals mining operation)

The upgrading of a third road train operation at Namakwa Sands mine in the Western Cape has been approved by the provincial road authority, but will only become operational in January 2014. Three additional PBS projects in mining are in the design/approval stage. All three are within the permissible maximum legal length and will operate on the general public road network in various provinces.

A summary of the operational and planned PBS demonstration vehicles in the mining industry as at November 2013 is given in Table 3-2.

Table 3-2 Operational and planned PBS vehicles in the mining industry as at November 2013

Date of first commissioning	Transport Operator	Commodity	No. of vehicles	Overall length (m)	PMCM (ton)
Oct 2011	Unitrans Mining	Gypsum	2	40.48	148.00
Jan 2013	Unitrans Mining	HMC ¹	11	42.77	185.00
Planned	Unitrans Mining	HMC ¹	5	31.29	121.25
Planned	Unitrans Mining	Various	tbd ²	20.54	73.25
Planned	Ngululu Bulk Services	Chrome ore	29	21.53	71.90
Planned	Barloworld Logistics	Platinum conc.	7	22.00	72.00

Notes: ¹ Heavy Metal Concentrate

² To be determined

3.5.3 Car-carriers

For the past three decades, it has been standard practice for South African car-carriers to operate under abnormal load permits, issued under Section 81 of the NRTA (DoT, 2003). These permits allow the vehicles to exceed legislated height and length limits by 300 mm and 500 mm respectively. Generally speaking, abnormal load permits are granted for indivisible loads (*e.g.* large machinery components), and so the granting of these permits to car-carrier operators has been under a special concession of the TRH11 (Technical Recommendations for Highways: Dimensional and Mass Limitations and Other Requirements for Abnormal Load Vehicles) (DoT, 2010). This concession was originally granted in response to requests from the car-carrier industry so as to improve productivity and remain economically competitive.

In 2006, at a meeting of the South African Abnormal Loads Technical Committee (ALTC), it was decided that this practice would be phased out due to concerns of vehicle safety (due to increased height), the definition of “indivisible load”, and instances of non-compliance by some operators. This decision is currently enforced by the omission of any reference to car-carriers in the latest edition of the TRH11 (DoT, 2010). The committee proposed that the granting of limited-period abnormal load permits would continue for existing car-carriers registered before 1st April 2010 on condition that the operator is RTMS-certified; any car-carriers registered after this date may not be granted permits (including new vehicles of the same design as existing vehicles).

To maintain levels of productivity to which the industry is accustomed, the ALTC has proposed a replacement framework for over-length and over-height car-carriers. The proposal suggests

that if an operator wishes to operate a car-carrier that exceeds prescribed height and length limits, two requirements must be met, namely:

- The transport operator must be certified in terms of the RTMS.
- The vehicle design must comply with the requirements of the PBS demonstration project in South Africa.

At this stage, PBS car carriers are required to meet the PBS Level 1 measures (Table 2-3), which allows them general accessibility on the road network. PBS car-carrier designs that have been approved as at November 2013 are summarised in Table 3-3.

Table 3-3 Operational PBS vehicles in the car-carrier industry as at November 2013

Manufacturer	Model	No. of vehicles	Overall length (m) ¹	PMCM (ton)
Unipower	Maxiporter Mk3 (short-long)	27	23	45.00
Unipower	Flexiporter Mk2 (semi-trailer)	20	23	30.10
Lohr	MHR 3.30 AS D1 + EHR 2.03 XS (50/50)	30	23	43.33
Lohr	SHR ZA (semi-trailer)	32	23	26.57
Rolfo	Rolfo Blizzard 6 Afro	21	23	26.90

Note: ¹ The maximum overall length is a prescriptive limit, allowing for a maximum vehicle combination length of 22 m and a maximum front and/or rear projection of 1.0 m

3.5.4 Other

As at November 2013, a number of PBS projects representing various industries were in the design or “awaiting approval” stages. These projects are summarised in Table 3-4.

Table 3-4 Planned PBS vehicles in various industries as at November 2013

Transport Operator	Commodity	No. of vehicles	Overall length (m)	PMCM (ton)
Barloworld Logistics	Motor vehicle parts	5	27.0	65.00
Barloworld Logistics	Cement	15	22.0	70.63
Beefmaster	Beef cattle	1	31.4	72.17
Buscor	Passengers	24	27.0	71.90
Momentum Logistics	Containers (wattle bark)	12	23.5	68.15

4 METHODOLOGY

This chapter describes the methodology used for the comparison of PBS and non-PBS vehicles. Section 4.1 describes the data samples and the vehicle category definitions used in the analyses. Two primary datasets formed the basis of the analyses:

- Vehicle trip data from pulp mills for all timber vehicles for the period June 2011 to September 2013, representing 491 290 trips.
- PBS and baseline vehicle data provided by PBS transport operators on a monthly basis for the period January 2008 to September 2013, representing 78 545 PBS vehicle trips.

In addition, detailed trip data were obtained from Timber Logistics Services for the analysis of fuel efficiency of PBS and baseline vehicles on an area basis and from Timbernology to investigate the effect of timber species on trip combination mass distribution. Section 4.2 describes the methodology for the validation of vehicle trip data obtained from the forestry pulp mills. Section 4.3 provides the approach taken to compare the distribution of trip combination mass of various vehicle categories with respect to payload control, overloading, under-loading and trip savings. The payload efficiencies of South African forestry PBS and baseline vehicles are compared with a sample of common heavy vehicles that were part of an OECD study and a selection of typical timber vehicles from eight countries. Section 4.4 describes the approach for the comparison of fuel efficiency between PBS and baseline data received from the PBS operators. The approach for estimating fuel savings and reduction in emissions during the sample period is also presented. Statistical analyses and the generation of histograms were done using the SAS statistical analysis software package (SAS, 2011).

4.1 Vehicle trip monitoring

During the early stages of the PBS initiative, parameters were identified for the monitoring of PBS demonstration vehicles and for comparing them with selected baseline vehicles, as far as possible with similar lead distances and operating on the same route(s). Initial parameters identified for monitoring are given in Appendix A. One of the requirements of PBS vehicle operators is that they must provide data as specified in the Smart Truck Demonstration Project Guidelines (CSIR, 2013a) to the CSIR on a monthly basis. These data have been collected since the start of the commissioning of the first two PBS vehicles in November and December 2007. For the purposes of this research, the measured data (per vehicle per month) were:

- (a) number of trips,
- (b) total kilometres travelled,
- (c) total tons transported,

- (d) total fuel consumed,
- (e) average trip combination mass, and
- (f) average trip payload.

From these data, average trip distance, fuel consumption and fuel efficiency were calculated for PBS and baseline vehicles.

In addition, vehicle trip data were obtained from all the forestry pulp mills in KwaZulu-Natal and Mpumalanga through the Forestry RTMS committee for the period 1 June 2011 to 30 September 2013. Although a smaller data sample could have been used, the dataset that was selected was readily available from the current service provider of the Forestry RTMS committee who has been collecting these data since June 2011. Data are received from the pulp mills and reported at the monthly Forestry RTMS committee meetings for monitoring the overloading and under-loading of timber vehicles of both RTMS-certified and non-RTMS-certified operators. Unless otherwise specified, “data sample” or “dataset” refer to this dataset.

For the purposes of the analyses, seven categories of vehicle combinations were defined representing the dataset received from the forestry pulp mills. Category A represents PBS vehicles (all with a Permissible Maximum Combination Mass (PMCM) > 56 t); Categories B, C and D represent vehicles with a PMCM = 56 t; and Categories E and F represent vehicles with a PMCM < 56 t as follows:

- A. RTMS/PBS > 56 t: PBS demonstration vehicles (that are by definition part of an RTMS-certified fleet),
- B. RTMS/non-PBS = 56 t: Vehicle combinations that are part of an RTMS-certified fleet with a PMCM = 56 t,
- C. Non-RTMS = 56 t; ≥ 50 vehicle trips per month (vtpm): Vehicle combinations that are not part of an RTMS-certified fleet with a PMCM = 56 t; companies with an average of more than or equal to 50 vtpm during the sample period, generally representing larger commercial fleets,
- D. Non-RTMS = 56 t; < 50 vtpm: Vehicle combinations that are not part of an RTMS-certified fleet with a PMCM = 56 t; companies with an average of less than 50 vtpm during the sample period, generally representing smaller non-commercial fleets,
- E. RTMS/non-PBS < 56 t: Vehicle combinations that are part of an RTMS-certified fleet with a PMCM < 56 t,
- F. Non-RTMS < 56 t: Vehicle combinations that are not part of an RTMS-certified fleet with a PMCM < 56 t, and
- G. Uncoded: Uncoded vehicles *i.e.* vehicles for which the PMCM is not linked to the truck/truck tractor registration number on any of the pulp mill weighbridge systems.

Uncoded vehicle combinations are allocated a default PMCM of 56 t, which, since many of the uncoded vehicles are smaller, results in an under-representation of the overloading levels and an over-representation of the under-loading levels of these vehicles. Because the PMCM of the uncoded vehicles (Category G) is unknown (and the percentage of the total sample is small) these data were excluded from the analyses. A summary of the data sample is given in Table 4-1.

Table 4-1 Trips per vehicle combination category for forestry pulp mill dataset

Vehicle category	Number of trips	% of sample
A. RTMS/PBS (PMCM > 56 t)	55 967	11.4
B. RTMS/non-PBS (PMCM = 56 t)	226 256	46.1
C. Non-RTMS (PMCM = 56 t, ≥ 50 trips/mth)	82 290	16.7
D. Non-RTMS (PMCM = 56 t, < 50 trips/mth)	43 371	8.8
E. RTMS/non-PBS (PMCM < 56 t)	4 664	0.9
F. Non-RTMS (PMCM < 56 t)	40 843	8.3
G. Uncoded vehicles	37 899	7.7
Total	491 290	100.0

A breakdown of the PBS vehicle trips per PMCM category for the same period is given in Table 4-2 and per PBS operator in Table 4-3. Table 4-1 shows that RTMS-certified operators make predominant use of vehicles with a PMCM = 56 t or PBS vehicles (representing 282 223 trips) rather than smaller vehicles with a PMCM < 56 t (Category E, representing 4 664 trips).

Table 4-2 Vehicle trips per PBS permissible mass category for forestry pulp mill dataset

Permissible Maximum Combination Mass (PMCM) (ton)	Number of trips	% of sample
64.0	1 431	2.6
67.0	9 988	17.8
67.5	35 394	63.2
70.0	9 154	16.4
Total	55 967	100.0

Table 4-3 Vehicle trips per PBS operator for forestry pulp mill dataset

Transport operator	Number of trips	% of sample
Timber Logistics Services	24 308	43.4
Buhle Betfu	9 394	16.8
Timbernology	6 990	12.5
Unitrans	6 929	12.4
Gaskells	5 223	9.3
Super Group	1 431	2.6
Timber 24	1 384	2.5
Zabalaza Hauliers	308	0.6
Total	55 967	100.0

Trip combination masses < 30 t in vehicle categories A to D, which represent 1 501 trips or 0.37% of the forestry pulp mill dataset, were excluded from the analyses. Vehicle combinations in these categories with a mass of approximately 20 t or less represent empty vehicles and combination masses in the range 20 to 30 t (for vehicles with a PMCM = 56 t) can be considered as part loads *i.e.* for various reasons, a full load in terms of mass or volume was not or could not be attempted.

Because Timber Logistics Services had both PBS and 56 t baseline vehicles operating simultaneously in a number of areas, summary data for the period July to September 2013 were obtained from this operator for a comparative analysis of fuel efficiency. A sample of PBS trip data during the period January 2011 to September 2013 was obtained from Timbernology for an analysis of the effect of timber species on trip combination mass distribution.

4.2 Data validation

As indicated in Section 4.1, vehicle trip data for all timber vehicles were obtained from the pulp mills for the period June 2011 to September 2013. Despite the fact that data validation was carried out for the purpose of reporting to the Forestry RTMS committee on a monthly basis, initial analyses indicated that certain errors and anomalies existed in the dataset. A number of adjustments and corrections were therefore effected:

- In some cases, PBS trucks that were either delivered before the corresponding PBS trailer or before the Abnormal Load permits were issued, were operated for periods of up to six months in combination with a legal trailer, thus operating as a legal 56 t combination. Some of these vehicles were coded as PBS vehicles throughout their operational period, hence

resulting in an increase in the number of under-loaded PBS vehicles. These trip data were transferred from the Category A (PBS) dataset to the Category B (RTMS, 56 t) dataset.

- In the case of one operator, the PBS trucks were replaced with new ones, after which the old trucks continued to operate in combination with legal trailers as part of the legal 56 t fleet. However, these trucks were still coded as PBS vehicles in the dataset. Again, these data were transferred from the Category A to the Category B dataset.
- Analysis of the PBS vehicle trip histograms per operator indicated a high concentration of combination masses in the 28 to 32 t range. It was established that these trips represented the delivery of wood chips, primarily to the Shincel mill near Richards Bay, KwaZulu-Natal. These trips were excluded from the PBS vehicle dataset. It should be noted that all trips representing non-PBS 56 t combinations transporting wood chips would have a combination mass < 30 t and were therefore excluded from the analysis, as indicated in Section 4.1.

A summary of the corrections is given in Table 4-4. Reasons for a PBS truck being operated as a legal vehicle during the permit period include:

- Urgent demand for timber transport on routes that are not approved for PBS vehicles.
- PBS trailer out of service for repairs or major servicing.

Table 4-4 Category A trips transferred to Category B dataset per PBS operator

Transport operator	No of PBS trips before corrections	No of PBS trips after corrections	Change
Timbernology	7 861	6 990	871
Unitrans	7 404	6 929	475
Gaskells	5 341	5 242	99
Total			1 445

4.3 Analysis of trip combination mass

The aim of this analysis was to determine whether there are significant differences in the variance (or distribution) of the combination mass of four categories of vehicle combinations, in the data sample as follows:

- RTMS/PBS: PBS demonstration vehicles,
- RTMS/non-PBS=56 t,
- Non-RTMS=56 t; ≥ 50 trips/month, and
- Non-RTMS=56 t; < 50 trips/month.

For the purpose of combination mass analysis, only vehicle categories A, B, C and D, which represent 90% of the sample, were considered. Categories B, C and D represent all vehicles in the sample with a PMCM of 56 t (vehicle combinations with seven or more axles).

The dependent variable used in the analysis is the combination mass. To statistically test whether there were differences in the variance of the combination mass, a test for homogeneity of variance was used while testing two vehicle categories at a time. The significance tests were done using Levene's Test for homogeneity of variance (Levene, 1960) using the data sample of > 30 t. Levene's test uses the p -value for the ANOVA F test on the dispersion variable. A 5% significance level was used, *i.e.* p -values are compared with a significance value of $\alpha=0.05$. Therefore, for this analysis, values below 0.05 imply that the null hypothesis of homogeneity of variances should be rejected and that the variances between the vehicle types are significantly different, while values above 0.05 imply that there are no significant differences between the variances of the vehicle types.

In doing the test, the software automatically converts the combination mass variable into a dispersion variable, calculated as the squared difference between each observation and the mean of the observations in each category. Due to the fact that the PBS vehicles (Category A) from the different transport operators have different PMCMs, the combination mass values for each group of PBS demonstration vehicles with a common PMCM were adjusted to the same mean as the PBS demonstration vehicle with the lowest PMCM (64 t) without affecting the variance. This was done by subtracting the difference in means (between each group of PBS demonstration vehicles and the 64 t PBS vehicles) from the combination mass values of the "non-64 t" PBS vehicles. Detailed outputs of the homogeneity of variance analyses are provided in Appendix C.

A further analysis of combination mass was performed to assess the level of overloading and under-loading of the various categories of vehicle combinations in the dataset. In this case, all six vehicle categories were analysed. Vehicles that operate in terms of the requirements of the National Road Traffic Regulations (DoT, 2013), *i.e.* all non-PBS vehicles in the sample, are allowed a 2% mass tolerance on total combination mass before the driver is charged for overloading. Because PBS demonstration vehicles operate on the public road network in terms of the abnormal load guidelines (DoT, 2010), no mass tolerance is permitted. This difference in the chargeable threshold has a direct effect on the target payload of PBS and non-PBS vehicles and hence the distribution of combination mass in relation to the PMCM. In order to conduct a meaningful comparison between PBS and non-PBS vehicles, the overloading and under-loading analyses involved aligning these two categories of vehicles in terms of their respective maximum allowable masses, above which an overload fine would be issued.

Using the monthly data provided by the PBS operators, the following monthly averages for PBS and baseline vehicles were calculated for 2011, 2012 and 2013 (Jan. to Sept.):

- (a) distance travelled (km),
- (b) trips (no.),
- (c) timber transported (tons),
- (d) combination mass (tons),
- (e) payload (tons), and
- (f) fuel consumption (ℓ/100 km).

4.4 Analysis of Fuel Efficiency

The objective of this analysis was to study the differences in fuel efficiency between two categories of vehicles, namely PBS and baseline (non-PBS) vehicles. Both categories of vehicles are part of RTMS-certified fleets. It has been proposed that PBS vehicles provide an overall improvement in fuel efficiency when compared with baseline vehicles. The validity of this theory was determined by evaluating the statistical significance of the difference in the fuel efficiencies between the two vehicle categories.

The data from all eight PBS operators in the forestry industry were sourced from the ‘Smart Truck Monitoring’ spreadsheets which contain the PBS and baseline vehicle data as described in Section 5.1. These spreadsheets are updated on a monthly basis on receipt of data from the PBS operators. A summary of the data used for the analysis of fuel efficiency of PBS and baseline vehicles is given in Table 4-5.

Table 4-5 Summary of PBS data used for fuel efficiency analysis

Transport Operator	No. of PBS vehicles	No. of Baseline vehicles	Data sample	No. of PBS trips
Super Group	1	1	Jan 2008 - Sept 2013	3 043
Timber 24	1	1	Jan 2008 - Sept 2013	3 549
Timber Logistics Services	15	5 to 17*	Jan 2010 – Sept 2013	37 801
Timbernology	7	3 to 11*	Jan 2011 – Sept 2013	9 992
Unitrans timber	7	3 to 6*	Aug 2011 – Sept 2013	6 514
Gaskells	5	8	Jan 2012 - Sept 2013	4 721
Buhle Betfu	10	5	May 2012 - Sept 2013	9 316
Zabalaza Hauliers	2	4	July to Sept 2013	198
Total	48	30 to 53*		75 134

* Note: Number of baseline vehicles varies during the sample period

For the purposes of this analysis, a fuel efficiency variable was calculated per vehicle per month as:

$$\mu_F = \frac{F}{P} \times s \quad (4.1)$$

where

μ_F	=	fuel efficiency [ℓ /ton.km]
F	=	total fuel used [ℓ]
P	=	average payload [tons]
s	=	total distance travelled [km]

This fuel efficiency variable was then used as the dependent variable in the analysis. A simple group t -test was used to test for a significant difference in average fuel efficiency between the two vehicle categories. Both the pooled and Satterthwaite t -tests were used, assuming equal and unequal variances respectively.

The estimated fuel savings per PBS operator was calculated using the monthly average payloads, distances travelled and fuel efficiencies of the baseline and PBS vehicles for the period January 2011 to September 2013. These results were used to calculate an estimated reduction in CO₂ emissions for the same period based on a conversion factor of 2.8 kg of CO₂ per litre of diesel burnt (OECD, 2011).

4.5 Payload efficiency

The Payload Efficiency Factor (PEF) can be defined as the maximum payload of a particular vehicle combination divided by the PMCM and is thus a measure of the efficiency of a vehicle combination if it is designed to carry maximum mass. For example, a vehicle combination with a PEF = 0.7 and a PMCM = 56 t, would have a permissible maximum payload of 39.2 t. As an international benchmarking exercise, the PEFs of a selection of South African forestry PBS and baseline vehicle combinations were compared with a number of vehicles from ten OECD member countries. These included common standard prescriptive trucks, high capacity and very high capacity combinations as described in the OECD report, *Moving Freight with Better Trucks* (OECD, 2011). Although many of these vehicles are designed for optimum payload *i.e.* mass, none of them are specifically designed to transport timber. The South African timber transport vehicles were therefore also compared with typical timber vehicles used in eight countries where forestry is a major industry.

4.6 Road wear and safety performance

A PBS demonstration vehicle is required to be more road-friendly in terms of road wear per ton of payload than the baseline vehicle for the same transport task. The methodology used for this road wear assessment is the approach used in the South African Pavement Design manual as described in Section 3.3.2. The road wear assessments of a number of PBS and baseline vehicles in the forestry and mining industries are presented. Mining vehicles were included in this part of the analysis due to the fact that the road wear assessments of a number of mining PBS vehicles clearly illustrate the potential benefit of a performance-based approach to road wear (Nordengen and Roux, 2013). It is intended that further research will result in the development of a South African infrastructure performance standard for road wear.

PBS safety performance assessments are based on the Australian scheme, as indicated in Section 3.2.1. For the purposes of the demonstration project, assessments of both the baseline vehicle and the proposed PBS design are required. The assessment of the baseline vehicle highlights any safety shortcomings of a legal vehicle (that meets all the heavy vehicle prescriptive requirements) whereas the assessment of the proposed PBS vehicle may have to be iterative, with design modifications eventually resulting in a final design that meets all the PBS requirements. Four comparisons between baseline and PBS vehicle assessment results are presented to highlight some of the safety performance improvements that have resulted through the implementation of the PBS demonstration project. These include a timber truck and drawbar trailer, a mining side-tipper road train, a car-carrier and a bi-articulated bus train.

The following chapter deals with the results of the analyses of the trip combination mass and fuel efficiency datasets. The PEFs of timber PBS vehicles are compared with those of vehicles from other countries. Results of road wear assessments of forestry and mining PBS vehicles are presented and discussed. Improved safety performance of four PBS vehicles, compared with baseline vehicles, is also presented.

5 RESULTS AND DISCUSSION

This chapter presents the monitoring and analysis results of PBS and baseline vehicles in the forestry industry. The main areas of analysis are the trip combination mass, including under- and overloading, payload efficiency and fuel efficiency. Analysis of the data shows the improved performance of PBS vehicles compared with RTMS/non-PBS and non-RTMS vehicles in terms of number of trips, loading accuracy and fuel efficiency.

The payload efficiencies of the South African forestry PBS vehicles are compared with those of a sample of truck combinations from eleven countries that participated in an OECD road freight study as well as a sample of timber trucks from eight countries. In addition, results of road wear assessments of a number of forestry and mining PBS and baseline vehicles are presented. This work is on-going and is being used to develop an infrastructure performance-based standard for road wear using the methodology on which the South African pavement design manual is based to ensure that PBS vehicles are more “road-friendly” than baseline vehicles.

Further, PBS assessment results of four PBS vehicles and their corresponding baseline vehicles are presented to demonstrate the potential safety benefits of implementing a PBS approach for heavy vehicles.

5.1 Overview of PBS dataset

The percentage of PBS vehicle trips transporting timber and tonnage transported by PBS vehicles increased during the sample period as indicated in Figure 5-1 (Tables D1-1 and D1-2, Appendix D1).

Figure 5-2 shows annual growth in PBS vehicle trips from 2008 to 2013 in the forestry industry (Table D1-3, Appendix D1). The total PBS vehicle kilometres travelled per year during the same period are shown in Figure 5-3 (Table D1-4, Appendix D1). These data have been used for the comparison of fuel efficiency and trip savings between PBS and baseline vehicles.

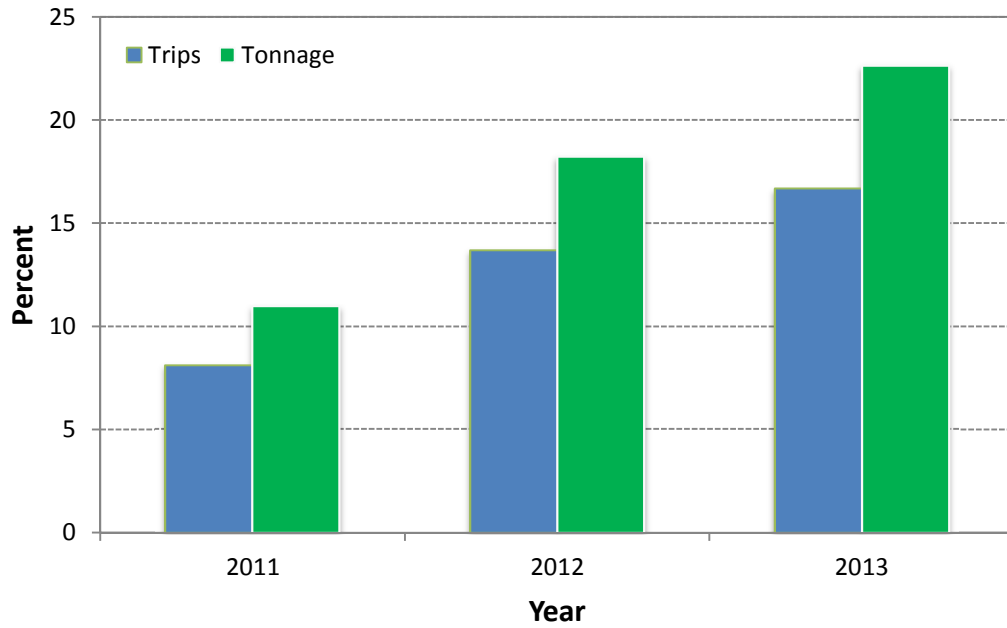

Figure 5-1 Percentage of PBS vehicle trips and tons transported in the forestry pulp industry for 2011 (June – Dec), 2012 and 2013 (Jan – Sept)

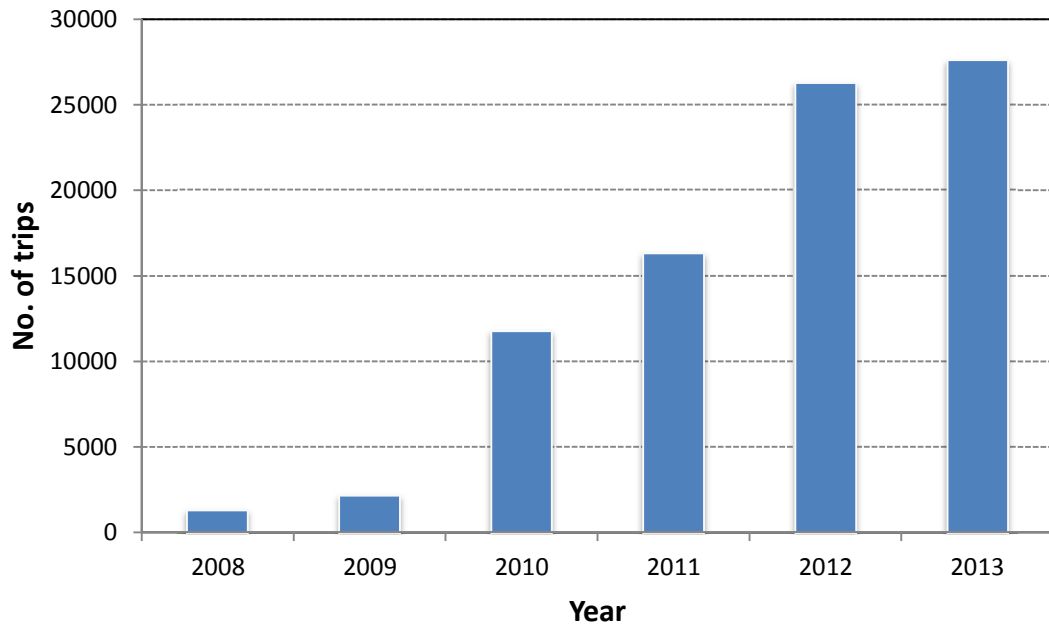

Figure 5-2 PBS demonstration vehicle trips from 2008 to 2013 (2013 value projected from January to September 2013 data)

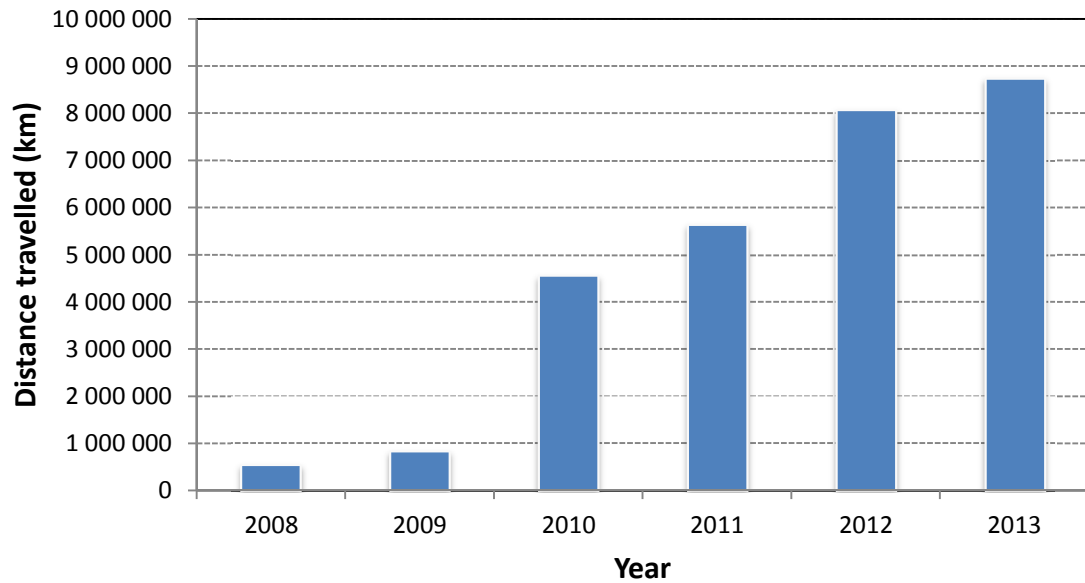

Figure 5-3 PBS demonstration vehicle kms travelled from 2008 to 2013 (2013 value projected from January to September 2013 data)

5.2 Trip combination mass

The trip combination mass distributions of vehicle categories A, B, C and D of the forestry vehicle dataset for combination mass > 30 t are shown in Figure 5-4. Histograms of the full dataset are given in Figure D2-1, Appendix D2. Similar mass distributions for vehicle categories D, E and F are shown in Figure 5-5. Vehicle Category D is included in both graphs for comparison purposes. Figure 5-5 suggests that there are three distinct vehicle combination groups with a Permissible Maximum Combination Mass (PMCM) < 56 t (Category F). Four common PMCMs were identified in this dataset *viz.* 16.5 t, 25.5 t, 43.5 t and 49.5 t. It is clear from Figure 5-4 that the 64 t and 67.5 t PMCM PBS categories are relatively well controlled in terms of loading compared with the 67 t and 70 t PMCM PBS categories. Figure 5-4 also clearly shows the 56 t PMCM limit with regards Categories B, C and D. The skewness of these datasets is discussed later in this chapter. Figure 5-6 shows the distribution of trip combination mass of two PBS operators, Timber Logistics Services and Timberology. Similar histograms of the other PBS operators are given in Figure D2-2 to D2-4, Appendix D2. The variation in trip combination mass distribution of the PBS operators is discussed later in this chapter.

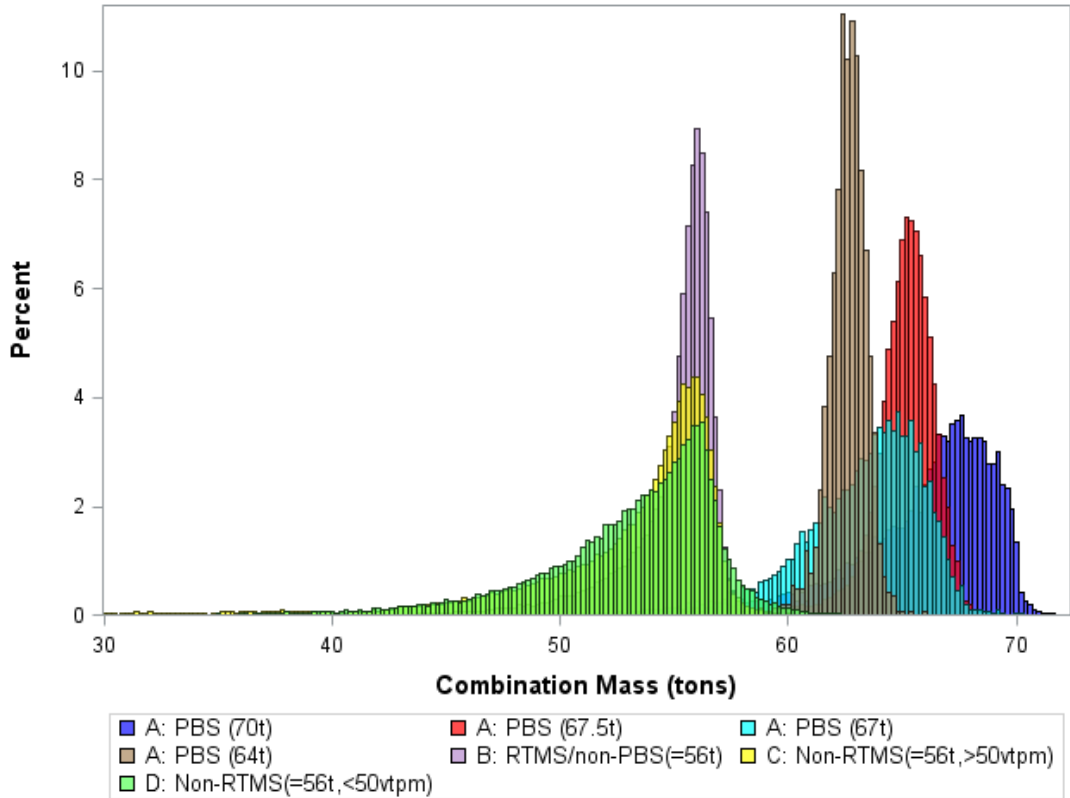

Figure 5-4 Distribution of trip combination mass for vehicle categories A to D for combination mass > 30 t

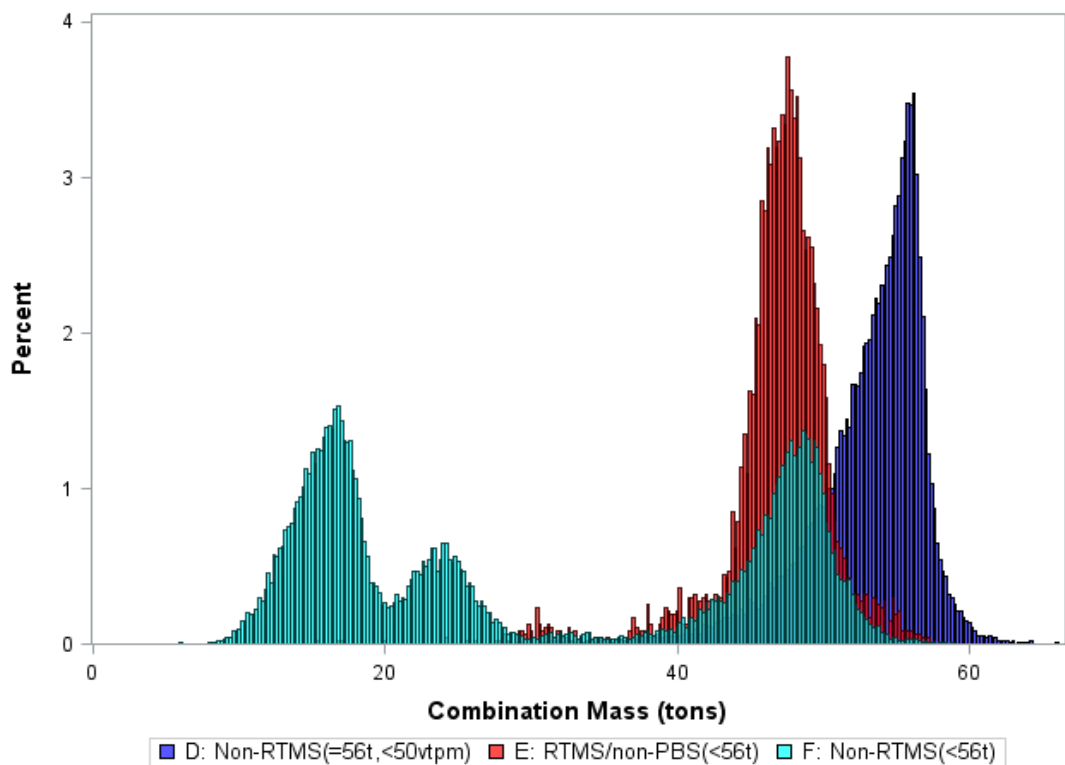

Figure 5-5 Trip combination mass distribution of RTMS/non-PBS < 56 t (Category E) and Non-RTMS < 56 t (Category F) vehicles

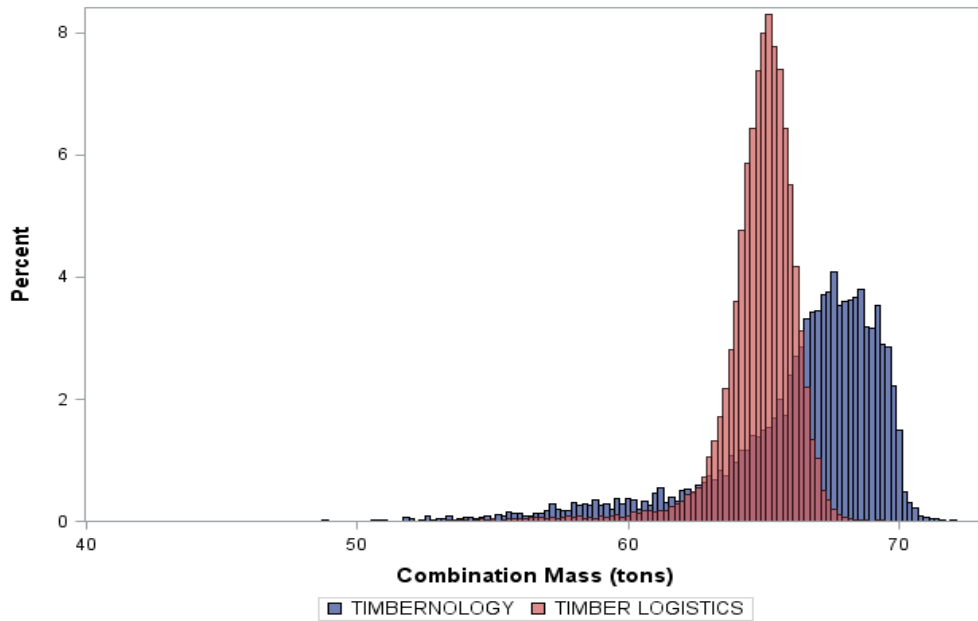

Figure 5-6 Distribution of trip combination mass for Timber Logistics Services (PMCM=67.5 t) and Timbernology (PMCM=70 t)

Statistical analysis using Levene's test for homogeneity of variance (see Appendix C and Table D2-1, Appendix D2) indicates that all the categories of PBS vehicles and the RTMS vehicles had a significantly lower variance than the 56 t non-RTMS vehicles ($p < 0.0001$). However, only two of the four categories of PBS vehicles (representing 65.8% of the PBS trips) had a significantly lower variance than the RTMS vehicles. Overall, the combination mass of the RTMS vehicles had a significantly lower variance than the PBS vehicles ($p = 0.0015$), although this test result was considerably less significant than all the other tests; the standard deviation of the PBS vehicles is only 2.8% higher than that of the RTMS/non PBS category. However, because of the large sample size, the significance test is able to confirm small differences between vehicle categories. Considering the variable nature of the bulk density of timber, which means that in some cases a full (mass) payload is not achievable, the standard deviation of the 64 t PBS vehicle category (974 kg), and even the 67.5 t PBS vehicle category (1 845 kg), is exceptionally low. Because all PBS vehicles form part of an RTMS-certified fleet, it is not unexpected that the variance of the RTMS/PBS and RTMS/non-PBS categories are not that different when compared with the non-RTMS vehicle category. One of the key indicators of the RTMS standard for transport operators is extent of overloading. Hence, all vehicles in an RTMS-certified fleet are required to be part of a load management system. In the case of forestry transport operations, because of the absence of weighbridges at loading zones, most vehicles in RTMS-certified fleets are fitted with on-board load cells. If calibrated on a regular basis, this equipment assists drivers in achieving their target payload, thereby minimising the risk of overloading and under-loading.

Significance tests were also done for all the PBS vehicle operators (per PMCM category), the results of which are provided in Table D2-3, Appendix D2. Three of these categories, representing 65.2% of the PBS trip sample, had a significantly lower combination mass variance than the RTMS/non-PBS vehicle category and two categories, representing 26.8% of the sample, had a significantly higher variance than the RTMS/non-PBS vehicle category. Zabalaza Hauliers was the only operator (representing 0.55% of the sample) with a significantly higher combination mass variance than both the RTMS and non-RTMS categories, the reason for which is suggested later in this section.

Table 5-1 provides the summary statistics of vehicle categories A to D for the data sample > 30 t. Similar statistics, excluding the skewness, are given for the whole sample for all vehicle categories in Table D2-2, Appendix D2. All the vehicle categories in Table 5-1 have negative values of skewness, indicating that these distributions have a tail to the left. This skewness is also visible in Figure 5-4, as well as most of the PBS vehicle combination mass histograms in Appendix D2 and is largely due to operators being more concerned about overloading (and the consequent risk of being penalised) than under-loading. The problem of volume-constrained loads resulting from low density timber is discussed later in this section.

Table 5-1 Summary statistics for PBS and non-PBS vehicles, Categories A to D and > 30 t for the sample period

Analysis Variable: Combination mass (kg)						
Vehicle category	N	Mean	Std Dev	Minimum	Maximum	Skewness
A. RTMS/PBS (Shifted CM) ¹	55 894	62 527	2 318	31 257	77 639	-2.24
B. RTMS/non-PBS (=56 t)	226 034	54 956	2 255	30 060	67 750	-2.71
C. Non-RTMS/>50vtpm ²	81 192	52 995	4 408	30 000	68 960	-2.15
D. Non-RTMS/<50vtpm ²	43 268	53 085	4 090	30 000	69 360	-1.48
C+D. Non-RTMS (=56 t)	124 460	53 026	4 300	30 000	69 360	-1.96
PBS vehicles per operator						
Super Group(64 t)	1 430	62 527	974	55 100	66 000	-2.27
Gaskells (67 t)	5 222	62 435	3 253	31 900	69 700	-1.69
Unitrans (67 t)	4 748	63 977	2 237	48 140	72 920	-0.81
Buhle Betfu (67.5 t)	9 392	65 498	1 844	34 260	76 540	-3.18
Timber 24(67.5 t)	1 382	64 701	2 528	49 400	72 720	-1.90
Timber Logistics (67.5 t)	24 269	64 823	1 592	44 000	70 740	-3.04
Zabalaza Hauliers (67.5 t)	308	60 885	5 622	42 900	70 150	-1.25
Timberology (70 t)	6 984	66 279	3 274	47 550	81 120	-1.71
Unitrans (70 t)	2 159	65 132	2 776	53 000	73 400	-0.53

Note: ¹ Combination masses of the 67, 67.5 and 70 t PBS vehicles aligned to the mean of the 64 t PBS vehicle for the statistical analysis of the Category A (PBS) dataset

² Vehicle trips per month

It is interesting to note that the three operators with the highest skewness values (ranging from -2.27 to -3.18) also have the lowest standard deviations (974 kg to 1 844 kg), suggesting that a higher degree of payload control results in a more effective distribution of trip combination mass in terms of the PMCM (legal mass limit). Furthermore, considering the four operators with vehicles in the 67.5 t category, the two with the highest skew values and the lowest standard deviations also have the highest average combination mass *i.e.* the highest average payloads. This demonstrates that a high degree of load control can result in improved compliance as well as a higher average payload.

It was further established that the PBS operators with the highest standard deviation of trip combination mass generally transport greater percentages of lower density timber (pine and wattle). The exception is Timber Logistics Services, which transports mostly gum. However, because this operator uses both 56 t and PBS vehicles in the same areas, the PBS vehicles are generally used to transport the higher density gum. Because the 56 t vehicles have a higher height restriction (4.3 m) than the 67.5 t PBS vehicles (4.2 m), the effect of lower density timber is less for 56 t vehicles.

Zabalaza Hauliers has a particularly high standard deviation (5 622 kg) and a relatively low average combination mass (60 885 kg) compared with the other three operators with 67.5 t PBS vehicles. Zabalaza Hauliers commenced operation of their two PBS vehicles on 2 July 2013 and by the end of September 2013 had recorded only 308 PBS vehicle trips. It was further established that for five weeks in August and September (approximately 75 trips), the PBS vehicles were used to transport a stockpile of dry gum, thus limiting the maximum achievable payload. This is also evidenced in Figure D2-3, Appendix D2.

In order to determine the reason(s) for the significant difference in the distributions of the trip combination mass of the various PBS operators, a sample of trip data (representing 6 553 trips during the period January 2011 to September 2013), which include the species of timber transported, was obtained from Timbernology, a PBS operator that operates seven of the nine 70 t PBS vehicles. Timbernology has the highest combination mass variance of the PBS operators, excluding Zabalaza Hauliers. Summary statistics per timber species are given in Table D2-4, Appendix D2, and the trip combination mass histograms per timber species are shown in Figure 5-7. It can be seen that the payload control is the best for pine (relatively high density) and the worst for wattle (low density).

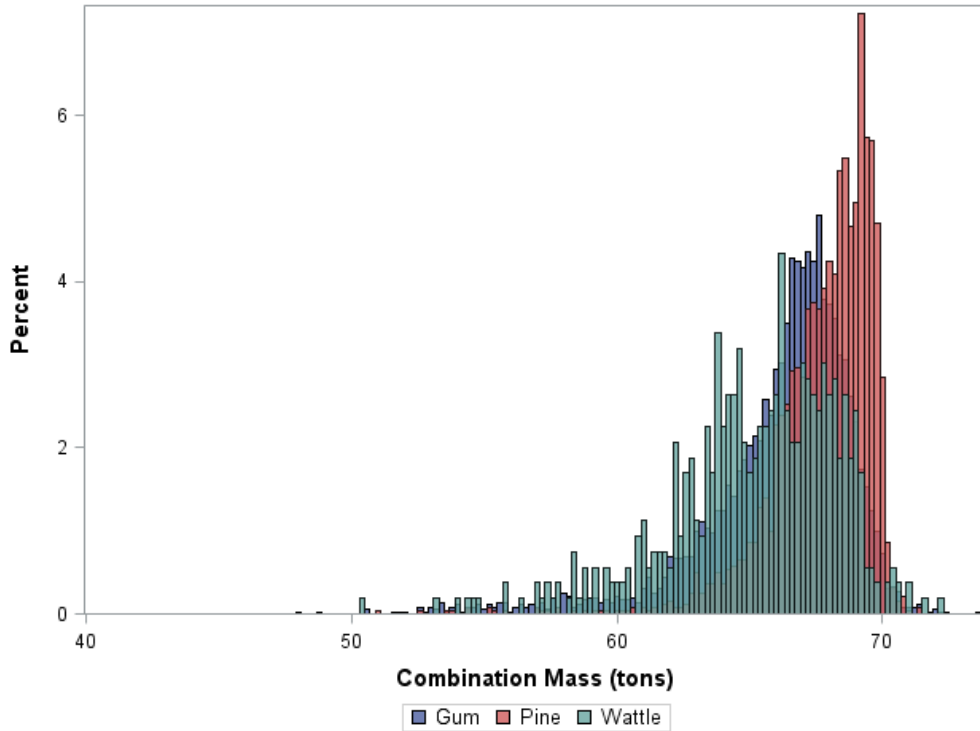

Figure 5-7 Trip combination mass distribution per timber species for Timbernology, data sample from January 2011 to September 2013

It is evident that low (and variable) density timber results in increased payload variability, which is largely due to payload volume constraints of the vehicle. However, having the flexibility of the use of smaller 56 t vehicle combinations together with higher capacity PBS vehicles can help to alleviate this problem as in the case of Timber Logistics Services. It is further evident that the selection of a PBS vehicle design should as far as possible take the primary species of timber that will be transported into account. In some cases, a PBS vehicle for transporting timber may be more productive if the volume rather than the mass capacity is maximised.

An analysis of the levels of under- and overloading of vehicle categories A to F was done, taking into account the difference in the maximum mass above which an overload fine is issued. This was achieved by aligning the critical measurable overloading and under-loading percentages of the PBS and non-PBS vehicles. Figure 5-8 and Figure 5-9 provide a comparison of the levels of under- and overloading for vehicle categories A to F respectively. A similar analysis was done using the sample excluding trips with a combination mass < 30 t (results not shown). The effect on the percentages under-loaded by more than 5% and 10% was marginal for the PBS vehicles and vehicles with a PMCM of 56 t.

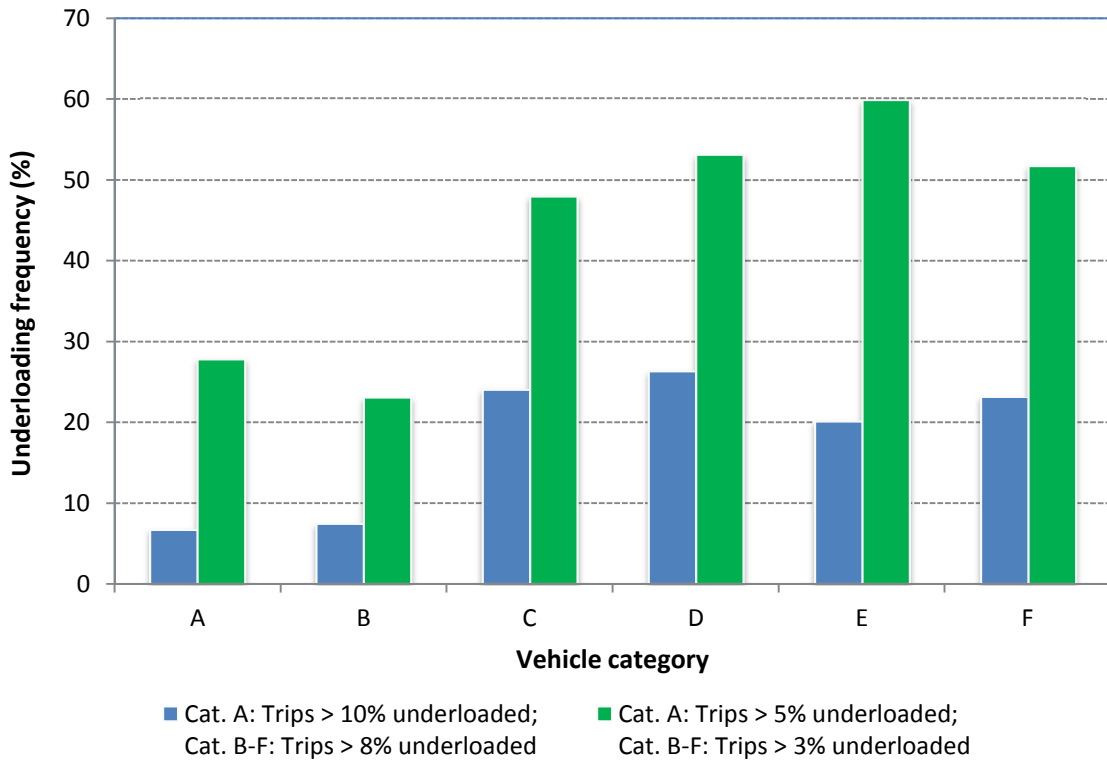

Figure 5-8 A comparison of measurable (aligned) levels of under-loading for vehicle categories A to F

Figure 5-8 (and Table D2-6, Appendix D2) shows that the frequency of under-loading beyond 5% of the PBS vehicles is higher than the corresponding frequency of under-loading for the Category B RTMS vehicles (56 t combinations). However, both these categories have considerably lower degrees of under-loading than the non-RTMS vehicles and the RTMS vehicles with a PMCM < 56 t (Category E). A possible explanation of the relatively high frequency of PBS vehicle under-loading at the 5% level is that the PBS operators are under a high level of scrutiny with regards overloading of their PBS vehicles. Repetitive overloading can lead to the withdrawal of PBS permits, which would have a significant negative impact on their productivity. Hence, operators are more likely to be over-cautious with regards the loading of their PBS vehicles. The same explanation may be applicable to the degrees of overloading for the different vehicle categories shown in Figure 5-9.

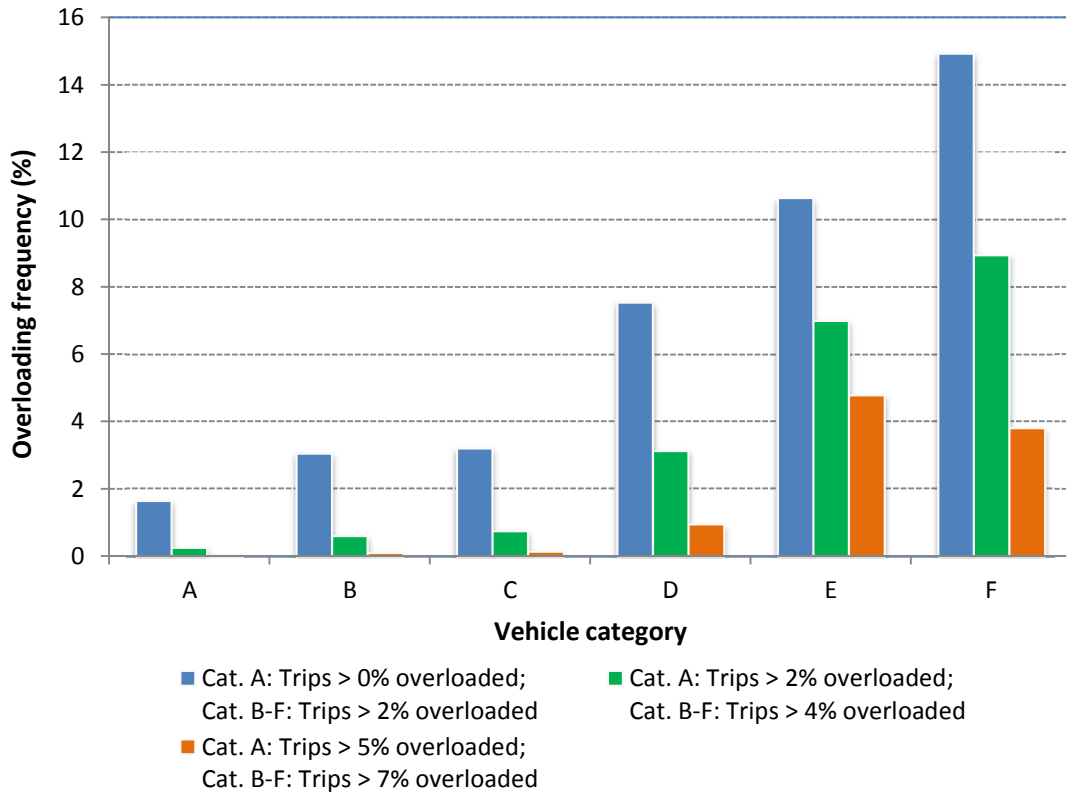

Figure 5-9 A comparison of measurable (aligned) levels of overloading for vehicle categories A to F

Figure 5-9 (and Table D2-6) illustrates the low extent of overloading of PBS vehicles above the chargeable limit (0%), as well as 2% and 5% above the chargeable limit compared with the RTMS and non-RTMS vehicles and their corresponding chargeable limits. Although the overloading frequency of 56 t RTMS (Category B) vehicles is only marginally less than that of 56 t non-RTMS (Category C) vehicles (>50 vehicle trips per month) (Figure 5-9), the under-loading frequencies of the 56 t RTMS (Category B) vehicles are considerably lower than all 56 t non-RTMS vehicles (Categories C and D) (Figure 5-8).

As indicated previously, volume constraint, in cases where the timber density is low, is a contributing factor regarding the under-loading of timber vehicles. This is a particular problem with species such as wattle and gum, and would generally apply to both PBS and non-PBS vehicles. However, in the case of most of the forestry PBS vehicles, the problem is more pronounced due to height restrictions that are imposed in the PBS assessment in order for the vehicle combination to comply with certain high speed directional performance standards, such as static rollover threshold, rearward amplification and high speed transient offtracking. The height limitations of three of the PBS demonstration vehicles (truck and trailer) are given in Table 5-2.

Table 5-2 Height restrictions of prescriptive vehicles and three PBS demonstration vehicle designs

Vehicle description	Maximum height (m)	
	Truck	Trailer
Prescriptive 56 t	4.3	4.3
PBS 67 t	4.2	3.8
PBS 67.5 t	4.2	4.2
PBS 70 t	4.2	3.8

Table 5-3 shows frequencies of overloading and under-loading per PBS operator for the sample period. Except for Timber 24, the frequencies of overloading above 2, 5 and 10% are very low. The high frequencies of under-loading below 5 and 10% of the PMCM of Zabalaza Hauliers reinforce the earlier observation regarding the combination mass standard deviation.

Table 5-3 Extent of overloading and under-loading of PBS operators for the sample period

Transport operator	No of trips	% of sample	Level of under-loading (%)			Level of overloading (%)			
			Trips >10% under-loaded	Trips >5% under-loaded	Trips >2% under-loaded	Trips >0% over-loaded	Trips >2% over-loaded	Trips >5% over-loaded	Trips >10% over-loaded
Timber Logistics Services	24 308	43.4	2.65	19.96	88.02	0.54	0.08	0.00	0.00
Buhle Betfu	9 394	16.8	2.53	11.76	62.24	2.69	0.29	0.09	0.02
Timbernology	6 990	12.5	12.96	39.18	77.11	1.65	0.23	0.09	0.01
Unitrans	6 929	12.4	11.07	46.53	81.95	3.54	0.75	0.04	0.00
Gaskells	5 223	9.3	20.14	57.96	87.88	1.23	0.11	0.00	0.00
Super Group	1 431	2.6	0.56	3.84	55.42	1.89	0.14	0.00	0.00
Timber 24	1 384	2.5	5.56	29.62	73.27	5.13	1.37	0.29	0.00
Zabalaza Hauliers	308	0.6	31.49	68.18	92.86	0.97	0.65	0.00	0.00
Total	55 967	100.0							

A summary of the average trips saved for 2011, 2012 and 2013 as a result of the increased payloads of PBS vehicles is given in Table 5-4. These data represent a summary of the data that are required by the CSIR on a monthly basis, as shown in Tables D2-7 to D2-9, Appendix D2.

Table 5-4 Trip savings of PBS demonstration vehicles compared with 56 t legal baseline vehicles, January 2011 to September 2013

Year	No. of PBS vehicles	No. of trips	Total trips saved	Average trips saved per month	Average trips saved per vehicle per month
2011	31 ^a	16 321	4 073	339	11.0
2012	46 ^b	26 268	6 517	543	11.8
2013	48 ^c	20 695 ^d	5 454 ^d	483	10.1

Notes: ^a 2 vehicles commenced operation in August and 5 in October 2011
^b 10 vehicles commenced operation in May 2012
^c 2 vehicles commenced operation in July 2013
^d Projected from January to September 2013 data

Based on the evaluation of PBS and baseline trip data, representing 63 284 PBS vehicle trips in the forestry industry from January 2011 to September 2013, a savings of approximately 11 trips per vehicle per month has been observed, or a total of 16 044 trips for the same period.

5.3 Fuel efficiency

The histograms in Figure 5-10 (and Box and Whisker plot in Figure D3-1, Appendix D3) show the distribution of fuel efficiency for the PBS and baseline vehicles for the period January 2008 to September 2013. From these plots the PBS vehicles appear to have better fuel efficiencies than the baseline vehicles. The fuel efficiencies were calculated from the data submitted by the PBS operators, as shown in Tables D3-1 to D3-3, Appendix D3. The mean fuel efficiencies for the two groups were shown to be 0.0157 ℓ /ton.km for the baseline vehicles and 0.0135 ℓ /ton.km for the PBS vehicles, an average improvement of 14.0% (Table D3-4, Appendix D3). The p -values for both the pooled t -test (which assumes equal variances) and the Satterthwaite t -test (which assumes unequal variances) are well below the significance level of 0.05 (Table D3-5, Appendix D3) and therefore indicate a highly significant difference between the fuel efficiency means and variances of the two groups.

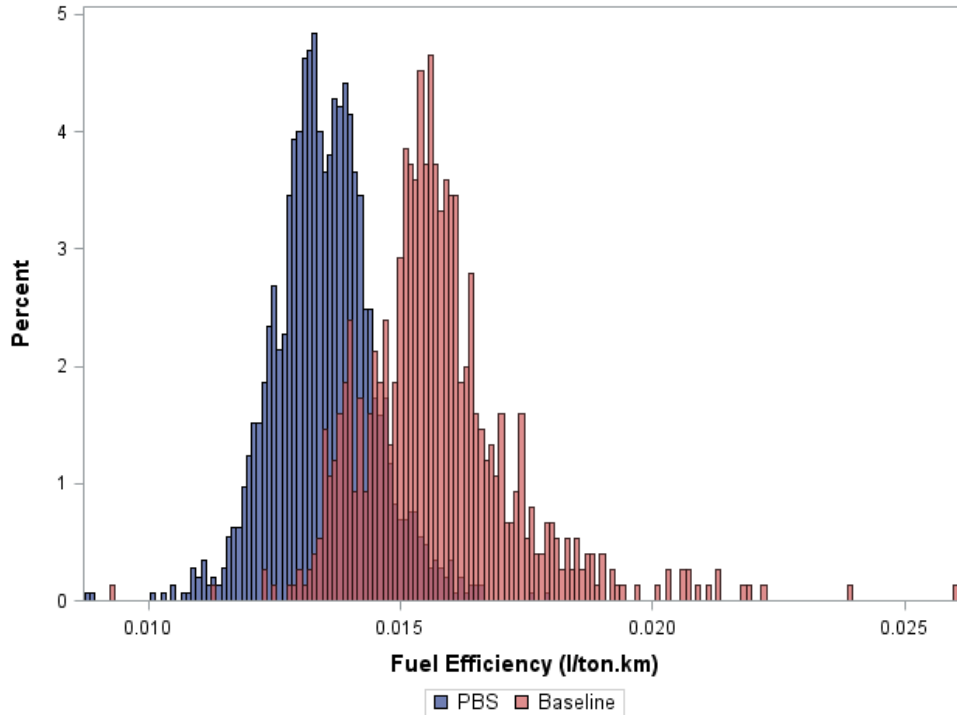

Figure 5-10 Histograms of fuel efficiency for baseline and PBS vehicles, January 2008 to September 2013

The average fuel efficiencies of the PBS and baseline vehicles per transport operator for the period January 2011 to September 2013 are shown in Figure 5-11 (and Appendix D3). It can be seen that the PBS vehicles are more fuel efficient than the baseline vehicles for all the PBS operators. The relatively high fuel efficiency of the Unitrans baseline vehicles can be partly attributed to the limited data records available for these vehicles. Only 24 data records were submitted for isolated months during the sample period compared with 165 records representing the seven PBS vehicles. This is due to the fact that the Unitrans timber fleet consists only of PBS vehicles, except when increased demand results in supplementary 56 t combinations being used for short periods of time.

Table 5-5 shows the average percentage fuel efficiency improvements per PBS operator for 2011, 2012 and 2013 (January to September) as well as the estimated fuel savings per operator as a result of using PBS vehicles, which amounts to approximately 1.85 million litres of diesel or an average of 66 000 l/month. The equivalent tons of CO₂, using a conversion factor of 2.8 kg of CO₂ per litre of diesel burnt (OECD, 2011), results in a reduction of 5 175 tons of CO₂ emissions in total during the sample period as a result of using the PBS rather than baseline vehicles. This amounts to approximately 185 tons of CO₂ per month. The savings of 5 175 tons of CO₂ is equivalent to 2 021 tons of coal or 7.33×10^6 kWh (EPA, 2013).

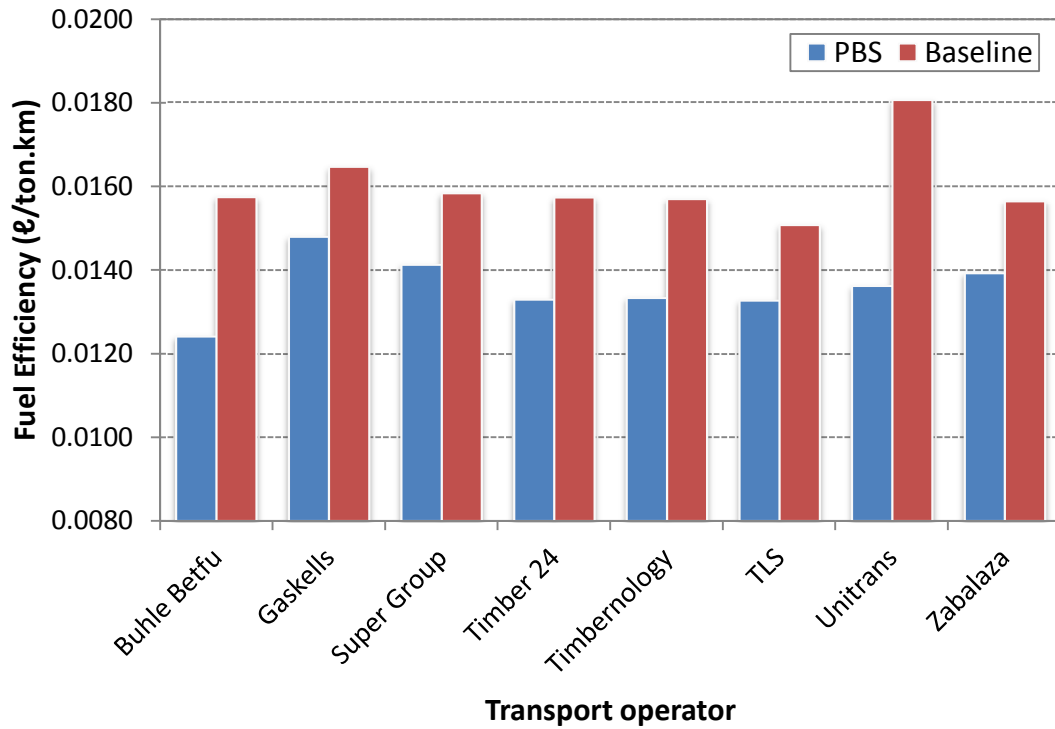

Figure 5-11 Average fuel efficiencies of PBS and baseline vehicles of the forestry PBS transport operators for the sample period

Table 5-5 Fuel efficiency improvements and estimated fuel savings per PBS operator, January 2011 to September 2013

PBS operator	Average fuel efficiency improvement (%)			Fuel savings (£/month)		
	2011	2012	2013	2011	2012	2013
SuperGroup	9.5	9.4	13.4	1 298	1 191	1 580
Timber 24	15.1	11.7	19.3	1 971	1 356	2 476
Timber Logistics Services	11.5	15.5	7.9	18 070	21 439	11 464
Timbernology	23.2	15.2	5.4	16 974	10 730	4 059
Unitrans	22.1	29.6	21.3	17 393	22 162	16 361
Gaskells	n/a	11.7	8.6	n/a	5 314	4 148
Buhle Betfu	n/a	22.7	19.7	n/a	17 666	13 283
Zabalaza Hauliers	n/a	n/a	10.9	n/a	n/a	2 186
Total fuel savings (£/month)				55 706	79 858	55 557
Total fuel savings (£/annum)				668 476	958 300	666 679
Reduction in CO ₂ emissions (tons/annum)				1 758	2 520	1 753

An average fuel efficiency improvement of 0.0022 ℓ /ton.km between the baseline and PBS vehicles translates to a reduction in CO₂ emissions of 0.0062 kg/ton.km. Based on an estimated

303 billion ton.km of road freight in South Africa during 2012 (CSIR, 2013b), and assuming 10% of this freight was transported by PBS vehicles similar to those participating in the PBS demonstration project, gives an estimated reduction in CO₂ emissions of 188 million tons per annum.

In order to isolate the effect of vehicles operating on different route profiles, an additional analysis of PBS and baseline vehicle fuel efficiency was carried out using a sample from Timber Logistics Services. The transport operator supplied summarised data of PBS and 56 t baseline vehicles operating in five different areas in KwaZulu-Natal during the period July to September 2013 (Table D3-6, Appendix D3). In this analysis, the PBS and baseline vehicles compared were operating on the same routes. Since only summary data were available, no statistical significance tests could be performed. However, from the average calculated fuel efficiencies, it can be seen in Figure 5-12 that the PBS vehicles were consistently more fuel efficient in all five areas. These average fuel efficiencies are 5.2% and 7.0% less than the averages for the full sample of the PBS and baseline vehicles, respectively.

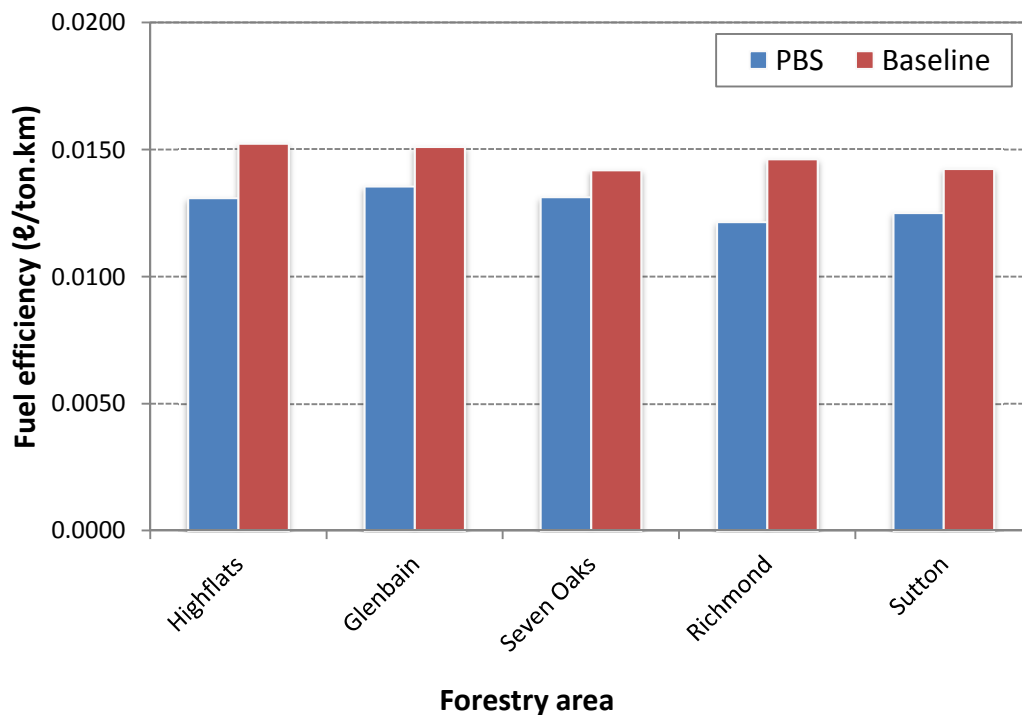

Figure 5-12 Fuel efficiencies of Timber Logistics Services' PBS and baseline vehicles operating in similar forestry areas in KwaZulu-Natal, July – September 2013

5.4 Payload efficiency

Figure 5-13 shows a comparison of the Payload Efficiency Factors (PEF) of a selection of South African forestry baseline and PBS vehicles with those of common standard prescriptive trucks, higher capacity and very high capacity vehicles from eleven countries that were used as part of the OECD study “*Moving Freight with Better Trucks*” (OECD, 2011). Some of these vehicles, particularly those with low PEFs, were designed for optimum volume rather than mass, and none of the vehicles are used for timber transport. Nevertheless, from a mass perspective, the PEFs of the South African timber vehicles compare favourably with the most efficient vehicles used in the OECD study. PEF details of the South African baseline and PBS vehicles are provided in Table D4-1, Appendix D4.

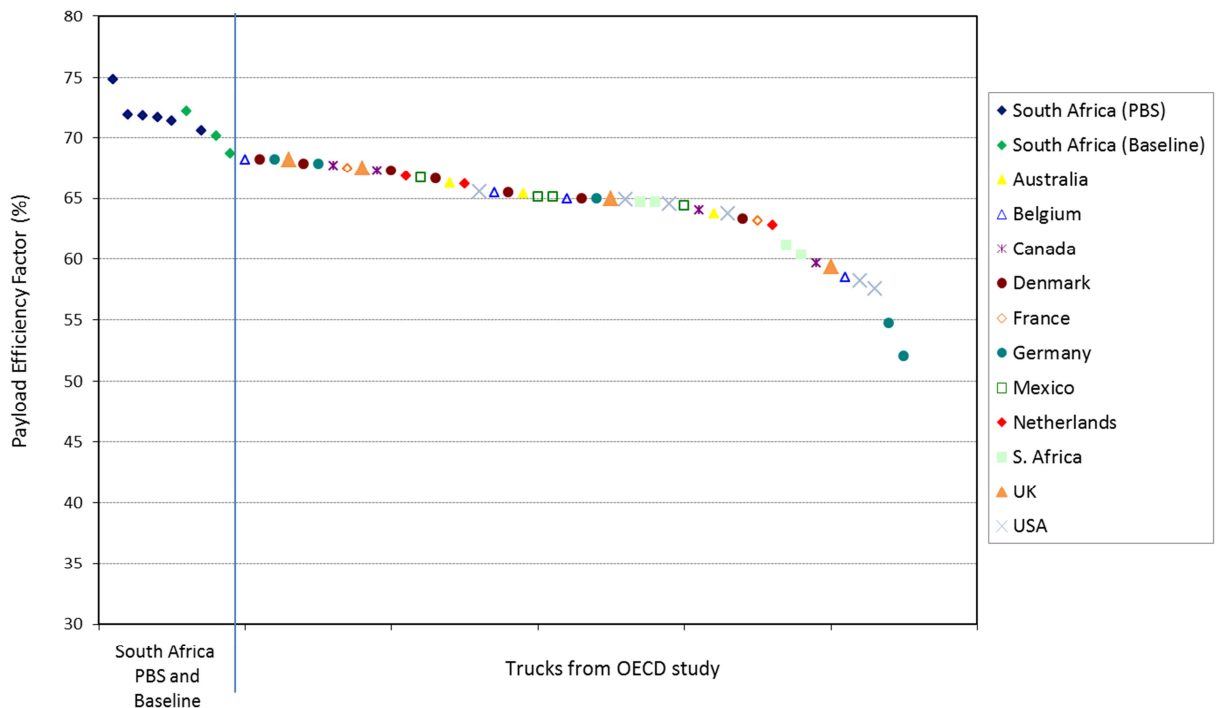

Figure 5-13 A comparison of Payload Efficiency Factors for SA forestry baseline and PBS vehicles with OECD study truck sample (source: OECD, 2011)

Figure 5-14 presents the PEFs of commonly-used standard and high capacity vehicles that are used for timber transport in Argentina, Australia, Brazil, Canada, Chile, New Zealand, Sweden and Uruguay (Baas and Latto, 1997; Efron, 2013; Elphinstone, 2003; Jokai, 2006; Lofröth *et al.*, 2012). Details are provided in Table D4-2, Appendix D4. It can be seen that the South African forestry vehicles have PEFs that are similar to the more payload-efficient forestry vehicles in other countries where forestry is a major industry.

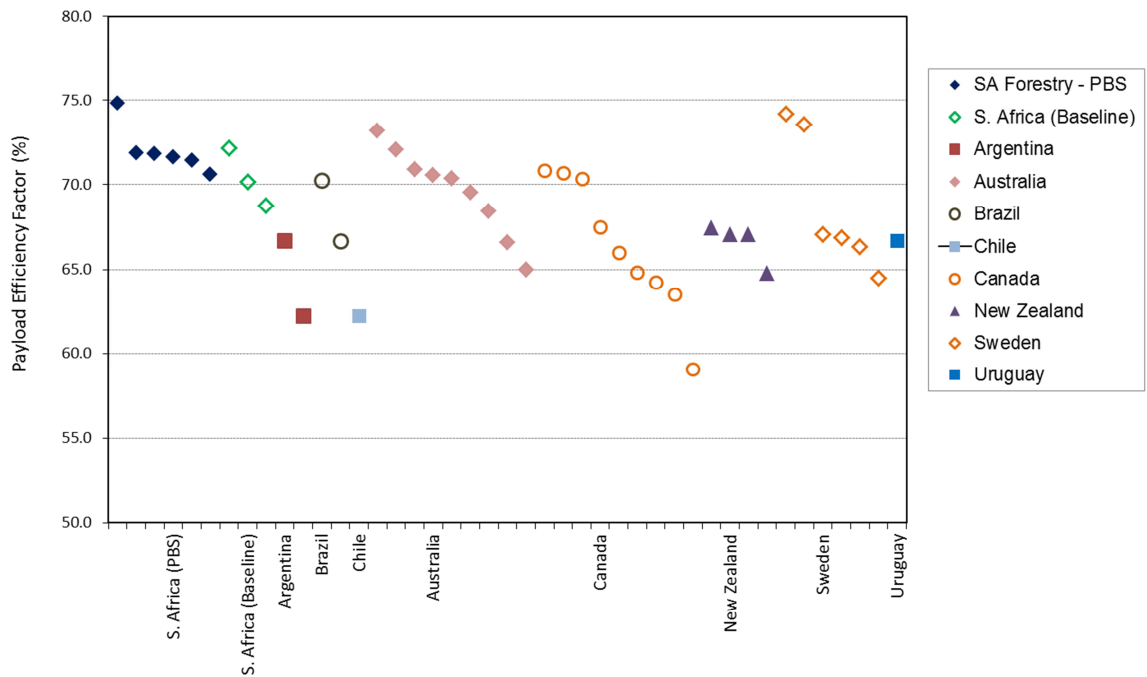

Figure 5-14 A comparison of Payload Efficiency Factors for SA forestry baseline and PBS vehicles and common timber transport vehicles in different countries

5.5 Road wear

As indicated in Section 3.3.2, the performance requirement in terms of road wear for a PBS demonstration vehicle is that it must generate less road wear per ton of payload than the baseline vehicle. A marginal increase in road wear may be allowed by the Review Panel if the other performance benefits of the proposed PBS vehicle are significant. Furthermore, as indicated in Section 3.3.1, and for the purposes of the PBS demonstration project, individual axle and axle unit loads must comply with the requirements of the NRTR.

As part of the road wear assessment of the first two PBS vehicles (introduced in November and December 2007), three baseline vehicles that are commonly used for transporting timber in South Africa were assessed. These comprised a 5-axle and a 6-axle articulated vehicle and a 7-axle rigid truck and drawbar trailer. As would be expected, the Load Equivalency Factor (LEF) per vehicle combination increases as the combination mass increases. However, the LEF per ton of payload decreases as the combination mass increases. Both the initial two PBS demonstration vehicles (PBS-F01 and PBS-F02) had an LEF/ton of payload below these three baseline vehicles.

The LEFs/ton payload of a number of forestry baseline and PBS vehicles are shown in Figure 5-15. A summary of the road wear assessment results for baseline and operational PBS vehicles in the forestry industry is given in Table D5-1, Appendix D5.

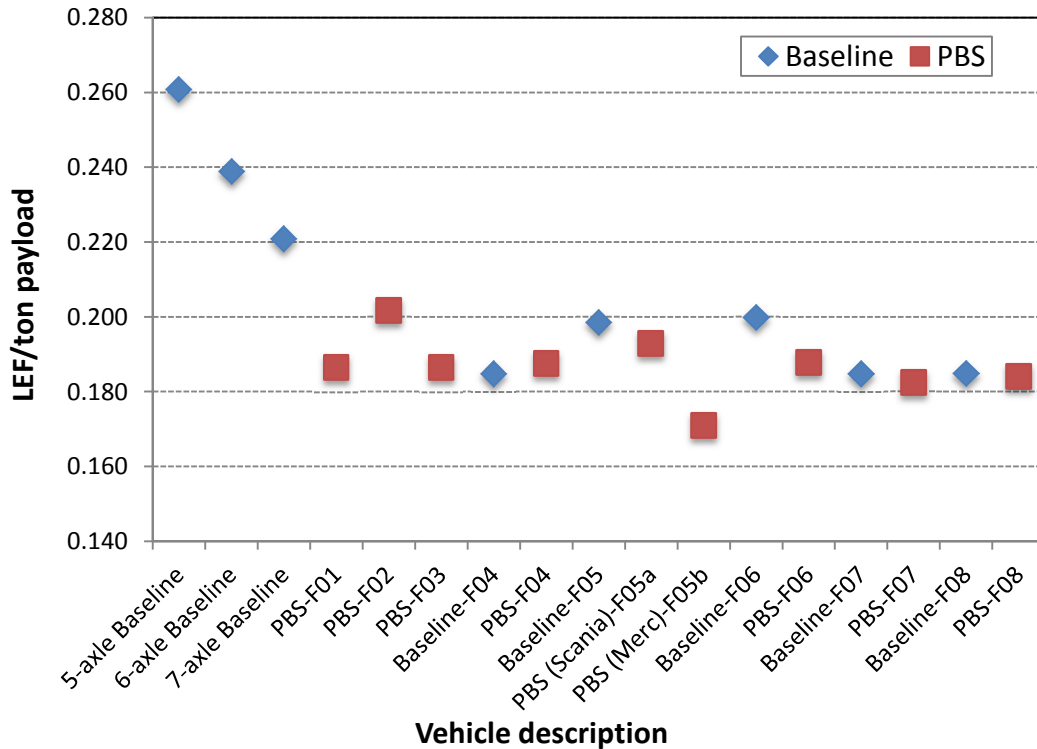

Figure 5-15 Summary of forestry industry PBS road wear assessments

As can be seen in Figure 5-15, the LEFs/ton payload of the initial baseline vehicles, in particular the 5-axle and 6-axle baseline vehicles, are significantly higher than the other forestry baseline and PBS vehicles. Figure 5-15 shows that in all cases except for the Sept. 2011 Timber Logistics Services project (Baseline-F04 and PBS-F04), the PBS vehicles have a lower LEF/ton payload than the corresponding baseline vehicles. In the case of the Sept. 2011 Timber Logistics Services project, the baseline vehicle has a particularly high payload capacity for a 56 t legal vehicle and hence a low LEF/ton payload.

Based on the results of the road wear assessments in the forestry industry, the introduction of a maximum limit of 0.200 or 0.195 LEF/ton payload (assuming the eight typical South African pavements in both wet and dry conditions as the basis of the assessment) as a performance measure of the road infrastructure performance standard would appear to be reasonable.

The LEFs/ton payload of the mining baseline and PBS vehicles are shown in Figure 5-16. A summary of the road wear assessment results of baseline and PBS demonstration vehicles in the mining industry is given in Table D5-2, Appendix D5. In November 2013 only the Unitrans

road trains at Richards Bay Minerals, KwaZulu-Natal, and Loeriesfontein, Northern Cape province, were operational. The remaining five projects were still in the design and/or approval stage(s).

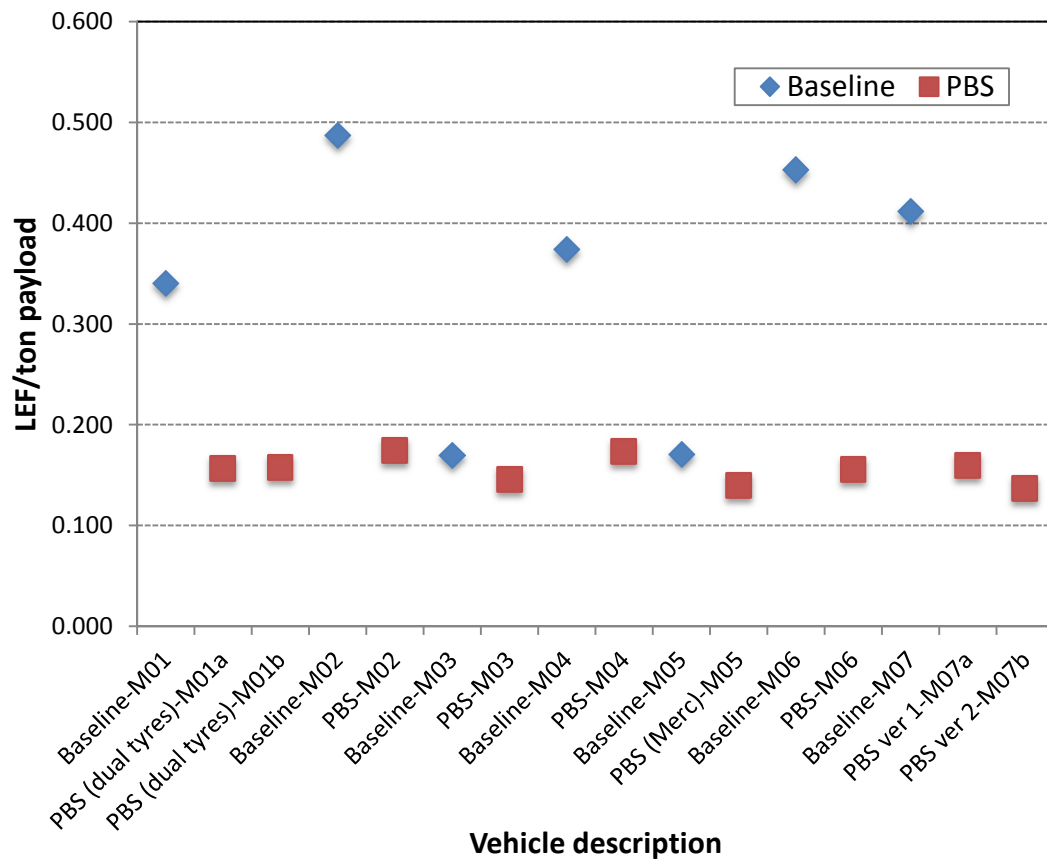

Figure 5-16 Summary of mining industry PBS road wear assessments

Five of the seven mining baseline vehicles were fitted with single tyres on all the trailers. In all these cases the LEF/ton payload exceeds 0.300, ranging from 0.340 to 0.487. In some cases, the baseline vehicle has a road wear impact of more than 100% greater than the corresponding PBS vehicle. In the two cases where the baseline vehicles were fitted with dual tyres (Unitrans Namakwa Sands, M03, and Ngululu Bulk Services, M05), the baseline vehicles cause 16.5 and 22.1% more road wear per ton of payload than the corresponding PBS vehicles.

One of the initial PBS mining road trains (PMCM = 174.1 t, PBS-M01, see Appendix D5) causes 9% more road wear (per ton of payload) than the baseline vehicle (PMCM = 145.1 t). Both these vehicle combinations have single tyres (425/65R22.5) on all the dollies and trailers. An alternative design (PBS-M01a) is fitted with dual tyres (315/80R22.5) on all the dollies and trailers and is more road friendly than the baseline vehicle by a factor of 2.2. The proposed PBS road train with single tyres (PBS-M01) has been excluded from Figure 5-16 as it represents an interim design.

As in the case of the forestry PBS vehicle road wear assessments, a maximum road wear limit of 0.200 or 0.195 LEF/ton payload would appear to be a reasonable performance measure for a road infrastructure performance standard. A performance standard for road wear will be proposed once a more representative sample of PBS vehicles, representing major industries utilising road freight transport, have undergone road wear assessments.

Three of the legal 56 t baseline vehicles shown in Figure 5-16 have road wear characteristics greater than 0.35 LEF/ton payload compared with < 0.20 for all the PBS vehicles. These baseline vehicles are fitted with single tyres, and although they comply with the prescriptive regulations, they cause approximately double the road wear per ton of payload than the PBS vehicles (and two other baseline vehicles with dual tyre-fitted trailers). This performance-based approach makes provision for designing more productive vehicles (trip reduction and fuel efficiency improvements) while at the same time reducing the road wear and ensuring a minimum acceptable standard in terms of on-road safety performance. The results of these road wear assessments suggest that the prescriptive maximum permissible mass for axles with single tyres is too high in relation to axles fitted with dual tyres. From a road wear perspective, axles fitted with single tyres should be used on trailers for the transport of low density products where the maximum payload is volume constrained. The use of wide-based tyres, such as 425 mm and 445 mm width tyres, does reduce the LEF/ton payload, but not nearly to the extent of the use of dual tyres (Roux and Nordengen, 2010).

Analysis of the road wear assessment results shows that a steering axle normally has a disproportionately high contribution towards the LEF of a vehicle combination due to its relatively high contact stress compared with axles fitted with dual tyres (Roux *et al.*, 2012a; Roux *et al.*, 2012b; Roux *et al.*, 2012c; Roux and Nordengen, 2013). Although the NRTR allow a maximum of 7 700 kg on a steering axle, PBS vehicles with a lower steering axle load as well as wider steering axle tyres (*e.g.* 385 mm rather than 315 or 285 mm width) are more likely to be more road-friendly than the corresponding baseline vehicles with a higher steering axle load.

5.6 Safety performance improvements

Figure 5-17 provides comparisons of four baseline and PBS vehicle assessment results, where significant improvements in safety performance results were observed: a timber truck and drawbar trailer (Prem and Mai, 2006), a mining BAB-quad road train (Dessein and Kienhöfer, 2011; Germanchev and Chong, 2011), a car-carrier truck and tag trailer (De Saxe and Kienhöfer, 2012, De Saxe *et al.*, 2012) and a bi-articulated bus (Kienhöfer, 2013). The normalised performance results are shown as percentages of the minimum or maximum requirement. Static Rollover Threshold (SRT) and Yaw Damping Coefficient (YDC) have

minimum requirements, hence the shaded “failure zones” are less than 100%, while Rearward Amplification (RA), High Speed Transient Offtracking (HSTO) and Tail Swing (TS) have maximum requirements, with corresponding failure zones greater than 100%. For example, the minimum requirement for SRT is 0.35 g *i.e.* the minimum lateral acceleration to cause rollover of any of the vehicle combination components. Figure 5-17 shows that the SRT of the timber and mining baseline vehicles is below the minimum requirement whereas both the PBS vehicles meet the SRT performance requirement. In the case of the car carrier, the baseline vehicle had a tail swing that exceeds the performance requirement of 300 mm by more than 200%. In each of the cases shown in Figure 5-17, the baseline vehicle, which meets all the prescriptive regulations in the NRTR, had one or more poor performance characteristics in terms of the PBS safety performance measures. The corresponding PBS vehicles, by definition, meet these performance requirements and hence can be considered safer vehicles, either in terms of performance standards related to slow speed tests, *e.g.* TS, or high speed tests, *e.g.* SRT, RA and YDC.

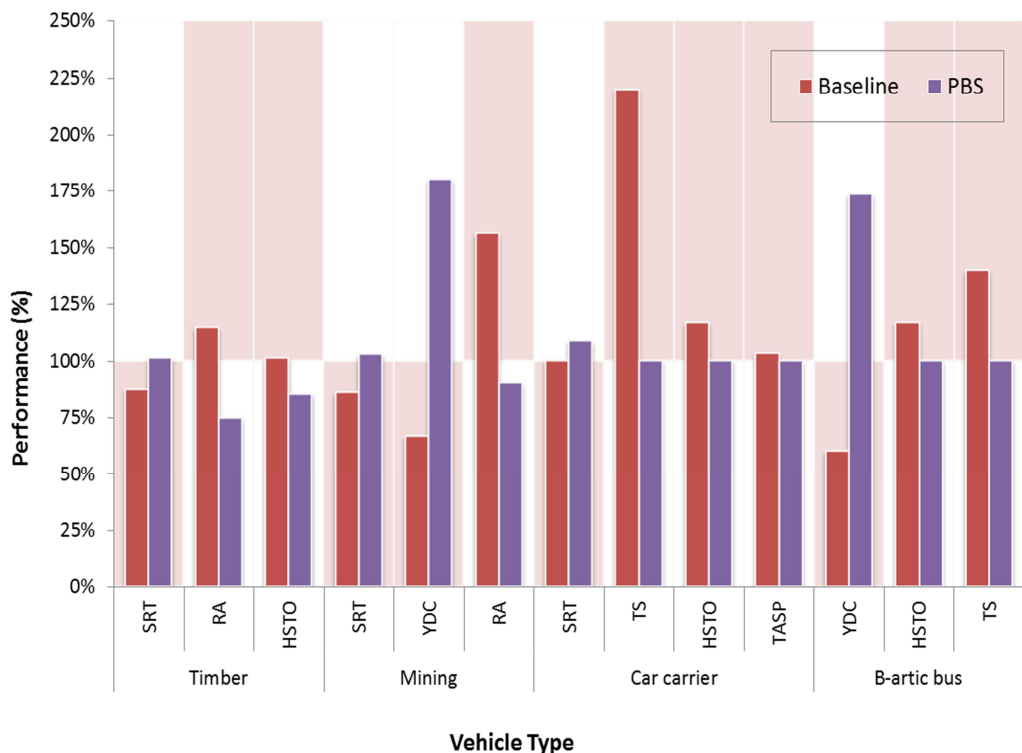

Figure 5-17 Summary of selected baseline and PBS vehicle assessment results for four vehicles

The following observations are relevant regarding the measured safety improvements:

- One of the solutions for addressing the poor SRT, RA and HSTO of the initial timber truck and drawbar trailer baseline vehicle (which is a common vehicle configuration in the forestry industry in South Africa) was to decrease the truck hitch offset resulting in

an “underslung” tow hitch. This modification has been implemented to a large extent on similar legal timber vehicle combinations by various trailer manufacturers, thereby having a positive impact on the safety performance of legal vehicles in the forestry industry (Prem and Mai, 2006).

- The mining baseline road train (A-triple) was in operation for approximately 10 years, with stability problems being experienced with the third trailer. A PBS assessment of this baseline vehicle highlighted poor performance characteristics of the design, particularly with respect to RA and YDC (Dessein and Kienhöfer, 2011; Germanchev and Chong, 2011) as indicated in Figure 5-17. The PBS BAB-quad road train, by virtue of its compliance to all the PBS performance measures, is likely to demonstrate improved safety performance over time. Eleven of these road trains have been operational at a heavy metals mine in KwaZulu-Natal province since January 2013. As at end-September 2013, the vehicles had travelled 1.01 million kms (19 700 trips) with no major or minor crashes or incidents, except for flat tyres, recorded.
- A survey of the tail swing performance of car-carriers in South Africa (De Saxe *et al.*, 2012), found that due to a shortcoming in the South African prescriptive regulations, which limit rear overhang to a maximum of 60% of the wheelbase of a vehicle (with no absolute maximum limit), very large overhangs (up to 7 m) are possible, resulting in large tail swings of up to 1.25 m. The study showed that 80% of car-carriers operating in South Africa have tail swings that exceed the 300 mm limit for Level 1 PBS vehicles as required by the Australian PBS scheme (NTC, 2008a). The five car-carrier combinations that have been assessed and are PBS-compliant all have tail swings ≤ 300 mm (De Saxe and Kienhöfer, 2012; De Saxe and Kienhöfer, 2013; De Saxe and Nordengen, 2013a; De Saxe, 2013a; De Saxe, 2013b). A proposal has been developed for regulating the use of car-carriers in South Africa using a PBS approach (De Saxe and Nordengen, 2013b).
- A 27 m bi-articulated bus train commenced operations in Mpumalanga province under Abnormal Load permit in October 2007. Another nine such buses were added during 2010. By the end of October 2013, these buses had travelled 1.78 million kms and transported 2.7 million passengers. The Smart Truck Review Panel indicated to the operator (Buscor) and OEM (MAN Truck & Bus) that further operation of vehicles not compliant with the prescriptive regulations would require the vehicles to be PBS-compliant. The original redesign suffered poor performance in terms of YDC and TS (Figure 5-17). Increasing the wheelbases of the second and third “trailers” resulted in a design that meets all the PBS requirements and a safer and more comfortable ride for passengers (Kienhöfer *et al.*, 2012; Kienhöfer, 2013).

6 DISCUSSION, CONCLUSIONS AND RECOMMENDATIONS

A performance-based standards (PBS) approach as the basis for heavy vehicle design and operation was first proposed in South Africa in the Department of Transport's National Overload Control Strategy (Steyn *et al.*, 2004). This was as a result of exposure to the PBS concept at the 6th and 7th International Symposiums for Heavy Vehicle Weights and Dimensions held in 2000 in Saskatoon, Canada, and 2002 in Delft, the Netherlands, respectively. An understanding of PBS for heavy vehicles was further expanded at a PBS seminar held in Melbourne, Australia, in February 2004. The 8th International Symposium for Heavy Vehicle Weights and Dimensions, which was held in 2004 in Johannesburg, South Africa, was an opportunity for extensive international exchange regarding the PBS approach. During 2004 and 2005 two delegations from South Africa undertook study tours in Australia in order to gain first-hand knowledge of both the self-regulation National Heavy Vehicle Accreditation Scheme (NHVAS) and the PBS initiative.

Ongoing international exchange during the past 10 years has contributed to the development of the PBS initiative in South Africa. These include the presentation of a vehicle dynamics course in Johannesburg and Stellenbosch with lecturers from the University of Michigan Transport Research Institute (UMTRI) and South Africa's participation in the International Transport Forum/OECD project "Moving Freight with Better Trucks: Improving Safety, Productivity and Sustainability" (OECD, 2007; OECD, 2011). South Africa's contribution to the PBS approach at an international level is evidenced by the five South African PBS-related papers presented at the 12th International Heavy Vehicle Transport Technology conference held in Stockholm in 2012.

The data collected in this study comparing PBS vehicles to their baseline counterparts has shown that the PBS approach to vehicle design provides a mechanism for improving safety, productivity, and road infrastructure preservation, and reducing CO₂ emissions and traffic congestion.

Specific objectives that have been met are the development of a framework for the design and operation of heavy vehicles in South Africa using a PBS approach, the evaluation of PBS and non-PBS vehicles operating in the forestry industry in terms of productivity, fuel efficiency and trip reduction, and providing initial results towards developing a South African performance standard for road pavement infrastructure based on road wear assessments of PBS and baseline vehicles in the forestry and mining industries. The final objective was to provide assessment

results highlighting improved safety performance of PBS demonstration vehicles compared with baseline vehicles.

6.1 Conclusions

A framework for designing and operating heavy vehicles using a PBS approach has been developed as part of a PBS demonstration project in South Africa. Fleets, of which PBS vehicles form a part, are required to be certified in terms of the Road Transport Management System (RTMS) accreditation scheme. The first two PBS demonstration vehicles started operating in the forestry industry at the end of 2007 and by November 2013, 62 PBS demonstration vehicles were operating in South Africa, 49 of which were in the forestry industry. The operation of the forestry PBS vehicles represents 78 545 trips and 26.2 million km for the period January 2008 to September 2013.

The trip combination mass standard deviation of PBS vehicles and RTMS/non-PBS vehicles was shown to be significantly less (47%) than non-RTMS vehicles, indicating a significantly higher accuracy of loading. Furthermore, the trip combination mass standard deviation of three of the PBS operators, representing 65% of the PBS trips during the sample period, was shown to be significantly less (30%) than the RTMS/non-PBS vehicles. The combination mass standard deviation and skewness of the PBS vehicles show that a higher degree of payload control (low standard deviation) results in a more efficient distribution of trip combination mass in terms of the average payload and Permissible Maximum Combination Mass (PMCM). The species of timber transported has an impact on the combination mass variance because of the variation of bulk density. Transportation of low density timber can result in sub-optimum payloads due to volume constraints. The payload centre of gravity of height has a critical impact on the results of a number of high-speed directional safety performance standards. Thus the selection of a specific PBS design when operating in an industry such as forestry (with variable density loads), should take the bulk density of the primary commodity (*e.g.* species of timber) to be transported into account.

Operators who manage prescriptive 56 ton vehicle combinations together with PBS vehicles have more flexibility in terms of achieving permissible maximum payloads on the PBS vehicles by using the prescriptive vehicles for the lower bulk density product.

An analysis of average payloads of the PBS and baseline vehicles from January 2011 to September 2013 indicates a savings of approximately 11 trips per vehicle per month, in total amounting to 16 044 trips saved. These benefits resulted in the number of forestry PBS vehicles increasing from 24 to 49 during the sample period.

Fuel efficiencies of PBS and baseline vehicles during the period January 2008 to September 2013 show a highly significant improvement in fuel efficiency of the PBS vehicles (0.0135 $\ell/\text{ton.km}$) compared with the baseline vehicles (0.0157 $\ell/\text{ton.km}$), representing an average fuel efficiency improvement of 14%. The fuel savings during the sample period was approximately 1.85 million litres. This is equivalent to 5 175 tons of CO₂ emissions or 185 tons of CO₂ per month. The fuel efficiency improvement converts to 0.0062 kg of CO₂/ton.km and is equivalent to 188 million tons of CO₂ if 10% of the 303 billion ton.km of road freight in South Africa during 2012 was transported by similar PBS vehicles.

The Payload Efficiency Factors (PEF) of the forestry PBS demonstration vehicles are in the range 70 to 75%. A comparison with general-use and forestry timber vehicle combinations from a number of countries indicated that, at an international level, the PBS study has resulted in a highly efficient heavy vehicle transport solution.

It was found that the trailers of heavy vehicles fitted with single tyres operating at the permissible maximum axle mass limits typically cause between 100 and 200% more road wear per ton of payload than similar vehicles fitted with dual tyres. The results of the road wear assessments suggest that the prescriptive permissible maximum mass for axles with single tyres is too high in relation to axles fitted with dual tyres. Further work in this area, involving road wear assessments of heavy vehicle combinations commonly used in other industries, is required in order to develop a performance standard for road pavement infrastructure in South Africa.

An evaluation of the PBS assessment of four PBS vehicles in different sectors (forestry, mining, car transport and passenger transport) showed that heavy vehicles that comply with the prescriptive regulations may have one or more shortcomings in terms of the required performance standards. These may include tail swing, static rollover threshold, rearward amplification, yaw damping coefficient and high speed transient off-tracking. PBS vehicles can thus have an improved on-road safety performance despite being longer and/or heavier than the corresponding baseline vehicles.

This study has shown that there are a number of significant potential benefits of adopting a PBS approach to heavy vehicle design and operation. However, because of the increased length and/or combination mass of most PBS vehicles, there is also the potential of increased safety risks if minimum driver and vehicle fitness standards are not maintained. Hence the prerequisite of certification in terms of the RTMS for fleets of which PBS vehicles form a part. The RTMS initiative has demonstrated significant improvements in fleet compliance and performance (RTMS, 2012) and appears to be a sound basis for managing operational risks of PBS vehicles.

Because of the high fatality and crash rates involving heavy vehicles in South Africa (OECD, 2011) and the relatively low level of on-road enforcement (Nordengen and Hellens, 1995; Nordengen, 1998; Killian *et al.*, 2008), particularly with regard to heavy vehicles, the RTMS and PBS initiatives offer an attractive opportunity for improving heavy vehicle safety performance besides improving road freight efficiency and reducing vehicle trips and CO₂ emissions. A growing number of RTMS and PBS fleets would allow traffic law enforcement authorities to focus their efforts on vehicles with a higher probability of non-compliance. In some provinces, the “weigh-less” principle is being applied to RTMS-certified vehicles, whereby these vehicles are not required to be weighed at a weighbridge (except for spot checks, preferably when the weighbridge is not busy), thus giving the operator the benefit of reduced travel times. The critical issue, particularly in developing countries such as South Africa, is to have adequate self-regulatory mechanisms in place to ensure that minimum vehicle and driver standards are maintained.

This study has made a significant contribution to the science of transporting freight. A number of unique findings have already made a valuable contribution to industry, roads authorities, transport costs, safety and the environmental impact of road freight transport. The PBS demonstration project in South Africa has shown that a performance-based approach to heavy vehicle design can be used to identify shortcomings in the dynamic and low speed performance of prescriptive heavy vehicles and provide the basis for designing heavy vehicles with an improved on-road safety performance. An improvement in payload control has resulted in a reduction of overloading and an increase in average payloads of the PBS vehicles compared with the prescriptive baseline vehicles. The demonstration project has also shown that the PBS approach results in productivity improvements as a result of improved fuel efficiency and trip savings. The improved fuel efficiency also resulted in a reduction of CO₂ emissions per ton.km. A PBS approach to the assessment of road wear has shown that PBS vehicles, although generally designed to transport higher payloads, can be designed to cause, in some cases, significantly less road wear per ton of payload than the corresponding baseline vehicles.

The author’s contribution to the development of the PBS framework in South Africa and the implementation of the PBS demonstration project included the following:

- Recommended a PBS approach in the South African National Overload Control Strategy report in 2004.
- Established the PBS committee in South Africa and has served as chairman since its inception.

- Proposed a link between the RTMS self-regulation scheme and the PBS demonstration project i.e. transport operators are required to obtain RTMS-certification for fleets in which PBS vehicles are to operate.
- Developed the PBS national strategy with input from PBS committee members.
- Obtained support from the Minister of Transport (through the National RTMS committee chair) to proceed with the PBS demonstration project in forestry.
- Introduced the Mechanistic-Empirical/LEF methodology (developed at the CSIR for evaluating road pavements and rehabilitation designs) for use as a performance standard for roads in the PBS initiative. The methodology was developed to more accurately optimise road designs. The author proposed that the same methodology could be used to optimise heavy vehicles in terms of their payload efficiency : road wear ratio.
- Developed guidelines for participation in the Smart Truck Programme.
- Established the PBS Review Panel and has served as chairman since its inception.
- Recommended use of the Abnormal Loads Bridge Formula (as described in the TRH11 guideline for abnormal loads) as a performance-based assessment approach for structures.
- Recommended a more principle-based approach for assessing structures (involving the comparison of maximum bending moments and shear forces generated by a reference load with those generated by the PBS design vehicle). The author was involved in the development of this approach for the assessment of all-terrain mobile crane vehicles in 2010.
- Developed a roadmap for car-carriers in South Africa, incorporating PBS compliance as a requirement for car-carriers that operate beyond the prescriptive maximum length and height limits. After some negotiation between government and industry, this roadmap, incorporating some minor changes, was approved by the Abnormal Loads Technical Committee in March 2014.

The specific study by the author has provided a unique database and set of results based on the operational performance of baseline and PBS vehicles over an extended period (2008 to 2013), showing the benefits of PBS vehicles in terms of:

- (a) improved fuel efficiency,
- (b) reduced emissions,
- (c) reduced road wear,
- (d) trip reduction,
- (e) improved safety performance in terms of vehicle dynamics, and
- (f) initial evidence of reduced crash rate.

The use of the South African Mechanistic-Empirical Design and Analysis Methodology (SAMDM) developed for road pavement design is a unique way to optimise vehicle design in terms of road wear.

6.2 Recommendations for further research

6.2.1 Volume versus mass constraints for commodities (such as timber) with a variable bulk density

Payload bulk density and the height of the payload centre of gravity are important parameters with regard to a number of performance standards, in particular the high speed directional standards such as SRT, RA and HSTO. In cases where variable density commodities, such as timber, are to be transported, model or methodologies to determine the optimum vehicle combination design in terms of maximising payload mass or volume would be useful tools in achieving cost-effective PBS design solutions. This would not be applicable to relatively high density payloads (where mass would always be the payload constraint) or relatively low density payloads (where volume would always be the payload constraint). Such research work would also be relevant to PBS vehicles designed to transport general freight *i.e.* mixed commodity loads.

6.2.2 South African performance standard for roads

An approach for assessing the road wear of PBS and baseline vehicles has been developed based on the South African pavement design methodology. This approach has been used in the PBS demonstration project as the road infrastructure performance standard. The requirement is that the proposed PBS vehicle must cause less road wear (on a representative sample of South African road pavement designs) than the corresponding baseline vehicle. Road wear assessments of a number of forestry and mining PBS vehicles suggest that a maximum road wear limit, expressed as a Load Equivalency Factor (LEF) per ton of payload, could be introduced as a road infrastructure performance standard. Road wear assessments of PBS design vehicles in a number of industries other than forestry and mining would contribute to this research work.

6.2.3 South African performance standard for road structures

Two approaches have been used in the PBS demonstration project to assess the safety of road structures: the South African abnormal loads bridge formula, which is used to assess applications for abnormal load mass permits, and a more principle-based approach of comparing maximum bending moments and shear forces generated by the proposed PBS vehicle with the corresponding effects generated by a reference bridge design load. Further work in this area

should result in the development of a performance standard for road structures, which could also potentially replace the current approach used to assess abnormal loads.

6.2.4 Performance characteristics of the South African heavy vehicle fleet

PBS assessments of a number of baseline vehicles have highlighted various shortcomings of the prescriptive heavy vehicle fleet in South Africa in terms of the PBS demonstration project safety performance standards. The benchmarking result of an OECD freight study (OECD, 2011) confirmed this finding as being applicable to some of the OECD member countries that participated in the project. An assessment of the performance characteristics of common South African heavy vehicle combinations, based on a selection of critical performance standards, would assist in identifying poorly performing vehicle combinations from a safety perspective. Such a study was conducted in Australia in 2001/02 (NRTC, 2002c). This work would be particularly relevant considering the poor road safety record in South Africa (Nordengen *et al.*, 2009).

6.2.5 Comparative analysis of crash rates

Crash statistics of both PBS and baseline vehicles have been collected since the commencement of the PBS demonstration project. By the end of September 2013, the crash rate of the PBS vehicles (based on 23.5 million kms) was 2.2 per million km compared with a crash rate of 3.4 per million km for the baseline vehicles (based on 67.4 million kms). Further research in this area is required based on a much larger sample of vehicle kms. One of the challenges is to achieve consistency in terms of the definitions of crashes and incidents between operators and between industries.

6.2.6 Prototype PBS designs

Should the PBS demonstration project in South Africa be successfully concluded, it is recommended that the development of prototype PBS designs should be considered in industries where PBS vehicles are particularly suited, such as forestry, mining and car transport. This approach was adopted in Canada (Section 2.4) and more recently in New Zealand (Section 2.3.5). Such an approach should not preclude the more generic approach that has been adopted in the South African demonstration project, but the prototype design approach would reduce the initial investment that is currently required to implement a PBS project and therefore increase the opportunity for smaller transport operators to participate in the PBS initiative.

REFERENCES

- AASHTO. 1977. *Standard Specifications for Highway Bridges*. Ninth Edition, 1965, Twelfth Edition, 1977. American Association of State Highway and Transportation Officials, Washington, D.C., USA.
- Agarwal, A.C. 1978. *Vehicle Weight Regulations across Canada: A Technical Review with Respect to the Capacity of Highway Systems*, Report RR 214. Ontario Ministry of Transportation and Communications, Toronto, Canada.
- Agarwal, A.C. and Billing, J.R. 1986. The Effect of Ontario's Weight Regulations on Commercial Vehicle Design, *Proceedings of the First International Symposium on Heavy Vehicle Weights and Dimensions*, 209-224. Kelowna, B.C., Canada.
- Agarwal, A.C. et al. 1997. *Impact on the Highway Infrastructure of Existing and Alternative Vehicle Configurations and Weight Limits*, Ontario Ministry of Transportation and Communications, Toronto, Canada.
- Anderson, J.R.B. 2011. *Load effects of mobile crane vehicles on bridge and culvert structures*. Report No. C1224-S-I. Vela VKE Consulting Engineers, Cape Town, South Africa.
- Anderson, R. and Sinclair, S. 1996. *Report of the Transport Committee on the Inquiry into Truck Crashes*. Transport Committee for the New Zealand House of Representatives 1.13B 175. New Zealand.
- Armstrong, M.D., Jung, F.W. and Phang, W.A. 1970. *A Proposed Method of Regulating Vehicle Weights in Ontario*. Report RR 166. Ontario Department of Highways, Toronto, Canada.
- Arredondo, J. 2012. Innovative and high productivity vehicles – the PBS scheme in Australia from 2007 to 2011. *Proceedings of the Twelfth International Symposium on Heavy Vehicle Transport Technology*, Stockholm, Sweden.
- ARTSA. 2003. *PBS Explained: Performance Based Standards for Road Transport Vehicles*, Issue 1. Australian Road Transport Suppliers Association, Melbourne, Australia. http://www.artsa.com.au/PBS_Explained_Sept_03.pdf.
- Austrroads. 2004. *Intelligent Access Program: Operational Guidelines – Overview*. Prepared by Koniditsiotis, C., Taylor, G., Davis, D. and Tomlimson, M. Austrroads, Sydney, Australia.
- Austrroads. 2004. *Intelligent Access Program (IAP): Stage 1 Implementation – Functional & Technical Specifications and Associated Testing Protocols (Draft)*. Prepared by Koniditsiotis, C. et al. Austrroads, Sydney, Australia.

- Baas, P.H. and White, D.M. 1989. Safety improvements for increased weights and dimensions in New Zealand, *Proceedings of the Second International Symposium on Heavy Vehicle Weights and Dimensions*. Kelowna, B.C., Canada.
- Baas, P.H. and Latto, D.J. 1997. *Logging truck stability analysis*. TERNZ Ltd., 2nd edition. Manukau City, New Zealand.
- Baas, P.H., Oliver, R. and Wright, I. 2002. *Accreditation of Assessors: Performance Based Standards*. National Road Transport Commission, Melbourne, Australia.
- Baring, J. and Koniditsiotis, C. 2008. Australia's Intelligent Access Program. *Proceedings of the Tenth International Conference on Heavy Vehicles*, 349-358. Wiley. Paris, France.
- Bedard, J. 1986. Vehicle Rollover Threshold Evaluation: An Assessment of Computer Simulation Models, *CCMTA/RTAC Vehicle Weights and Dimensions Study Technical Report Volume 12*. Roads and Transportation Association of Canada, Ottawa, Canada.
- Bennett, D., Styles, E. and Wright, I. 2003. Benefits of performance based standards for heavy vehicles. *Proceedings of the 21st ARRB and 11th REAAA conference*, 54-68. Cairns, Australia.
- Billing, J.R. 1986a. Demonstration Test Program: Summary of Tests of Baseline Vehicle Performance, *CCMTA/RTAC Vehicle Weights and Dimensions Study Technical Report Volume 3*. Roads and Transportation Association of Canada, Ottawa, Canada.
- Billing, J.R. 1986b. Demonstration Test Program: Five, Six and Seven Axle Tractor Semitrailers, *CCMTA/RTAC Vehicle Weights and Dimensions Study Technical Report Volume 4*. Roads and Transportation Association of Canada, Ottawa, Canada.
- Billing, J.R. 1986c. Comparison of Simulation and tests of Baseline and Tractor-Semitrailer Vehicles, *CCMTA/RTAC Vehicle Weights and Dimensions Study Technical Report Volume 5*. Roads and Transportation Association of Canada, Ottawa, Canada.
- Billing, J.R. 1986d. Hitch Slack and Drawbar Length Effects on C-train Stability and Handling, *CCMTA/RTAC Vehicle Weights and Dimensions Study Technical Report Volume 6*. Roads and Transportation Association of Canada, Ottawa, Canada.
- Billing, J.R., Lam, C.P. and Couture, J. 1989. Development of Regulatory Principles for Multi-axle Semitrailers, *Proceedings of the Second International Symposium on Heavy Vehicle Weights and Dimensions*. Kelowna, B.C., Canada.
- Billing, J.R. and Lam, C.P. 1992. Development of Regulatory Principles for Straight Trucks and Truck-trailer Combinations, *Proceedings of the Third International Symposium on Heavy Vehicle Weights and Dimensions*, 36-44. Cambridge, England.
- Billing, J.R. and Madill, R.B. 2010. Introduction of long combination vehicle in Ontario. *Proceedings of the Eleventh International Symposium on Heavy Vehicle Transport Technology*. Melbourne, Australia.

- Billing, J.R. and Patten, J.D. 2003. *Performance of Infrastructure-friendly Vehicles*, National Research Council of Canada, Report CSTT-HVC-TR-058. Ottawa, Canada.
- Billing, J.R. and Patten, J.D. 2004. *Full-scale Performance Testing of 5-axle Semitrailers*. National Research Council of Canada, Report CSTT-HVC-TR-084. Ottawa, Canada.
- Billing, J.R. 2008. Personal communication. National Research Council of Canada, Agincourt, Canada, 9 July 2008.
- Borbely, C.L., Gilks, G. and Pearson, J. 2000. Challenges to using performance criteria as a basis for vehicle weight and dimension regulations. *Proceedings of the Sixth International Symposium on Heavy Vehicle Weights and Dimensions*, 323-335. Saskatoon, Canada.
- Bruzsa, L., Sack, R. and Shepherd, G. 2008. Smart Technologies and Policies for the Effective Management of Heavy Vehicles. *Proceedings of the Ninth International Symposium on Heavy Vehicle Weights and Dimensions*. State College, Pennsylvania, USA.
- Bruzsa, L. 2013. Personal communication. National Heavy Vehicle Regulator, Brisbane, Australia, 14 October 2013.
- Calvert, F. 2004. Improving Regulation of Heavy Vehicles: Performance-Based Standards. *Proceedings of the Eighth International Symposium on Heavy Vehicle Weight and Dimensions*. Johannesburg, South Africa.
- Christison, J.T. 1986a. Pavements Response to Heavy Vehicle Test Program - Part 1, Data Summary Report, *CCMTA/RTAC Vehicle Weights and Dimensions Study Technical Report Volume 8*. Roads and Transportation Association of Canada, Ottawa, Canada.
- Christison, J.T. 1986b. Pavements Response to Heavy Vehicle Test Program - Part 2, Load Equivalency Factors, *CCMTA/RTAC Vehicle Weights and Dimensions Study Technical Report Volume 9*. Roads and Transportation Association of Canada, Ottawa, Canada.
- Christison, J.T. 1986c. Pavements Response to Bump Induced Axle Loads: Experimental Findings, *CCMTA/RTAC Vehicle Weights and Dimensions Study Technical Report Volume 10*. Roads and Transportation Association of Canada, Ottawa, Canada.
- CMVSS. 2007a. C-dolly Specifications. [Internet] Canadian Motor Vehicle Safety Standard 903. Transport Canada, Ottawa, Canada. Available from: <http://www.tc.gc.ca/acts-regulations/GENERAL/m/mvsa/regulations/mvsrg/900/mvsr903.html>. [Accessed: 4 July 2008]
- CMVSS. 2007b. C-dolly Hitch Requirements. [Internet] Canadian Motor Vehicle Safety Standard 904. Transport Canada, Ottawa, Canada. Available from: <http://www.tc.gc.ca/acts-regulations/GENERAL/m/mvsa/regulations/mvsrg/900/mvsr904.html>. [Accessed: 4 July 2008]

- Coleman, B.L., Sweatman, P.F. and Di Cristoforo, R. 2003. *Approval for a 16.6m (54.5ft) intermodal container semi-trailer*. Roaduser Systems Report RUS-03-837-01-03. Melbourne, Australia.
- Corbin, G, Grandbois, J. and Richard, M.J. 1995. Evaluation of Self-steering Axles for Semitrailers. *Proceedings of the Fourth International Symposium on Heavy Vehicle Weights and Dimensions*, 525-536. Ann Arbor, Michigan, USA.
- CSA. 1978. *Design of Highway Bridges*, Canadian Standards Association, CAN/CSA-S6. Published in 1922, 1929, 1938, 1952, 1966, 1974, 1978 and 1988. Mississauga, Ontario, Canada.
- CSIR. 2007. *Performance-Based Standards (PBS) Strategy for Heavy Vehicles in South Africa*. National Department of Transport, Pretoria, South Africa.
- CSIR. 2013a. *Smart Truck programme: Rules for the development and operation of Smart Trucks as part of the Performance-Based Standards research programme in South Africa*. Council for Scientific and Industrial Research, Pretoria, South Africa.
- CSIR. 2013b. *9th Annual state of logistics survey for South Africa 2012*. Council for Scientific and Industrial Research. ISBN 978-0-7988-5609-6. Pretoria, South Africa. Available from: www.csir.co.za/sol.
- CSRA. 1981. *TMH 7: Code of Practice for the design of highway bridges and culverts in South Africa*. Committee for State Road Authorities, Pretoria, South Africa.
- CSRA. 1985. *TRH 14: Guidelines for road construction materials*. Committee for State Road Authorities, Pretoria, South Africa.
- De Beer, M., Sallie, I.M. and Van Rensburg, Y. 2008. *Revision of TRH 11 (1999-2000): Recovery of Road Damage - Discussion Document on a Provisional Basis for Possible New Estimation of Mass Fees*. National Department of Transport, Pretoria, South Africa.
- De Beer, M., Sallie, I.M., Van Rensburg, Y. and Kemp, M. 2009. *Load Equivalency Factors (LEFs) for Abnormal Vehicles (AVs) and Mobile Cranes in South Africa based on the Mechanistic-Empirical Design Methodology*. Post-conference update of published paper at SATC 2009, Session 2B: Infrastructure 2, Proceedings of the 28th Southern African Transport Conference. ISBN 987-1-920017-39-2. Pretoria, South Africa.
- De Beer, M., Maina, J. and Netterberg, F. 2012. Mechanistic modeling of weak interlayers in flexible and semi-flexible road pavements: Part 2. *Journal of the South African Institution of Civil Engineering*, Vol 54, No. 1, pp 43-54. Midrand, South Africa.
- Delisle, G. and Pearson, J.R. 1986. Investigating Articulated Vehicle Roll Stability Using a Tilt Table Device, *CCMTA/RTAC Vehicle Weights and Dimensions Study Technical Report Volume 7*. Roads and Transportation Association of Canada, Ottawa, Canada

- De Pont, J. J., Mueller, T. H., Baas, P. H. and Edgar, J. P. 2000. Performance measures and crash rates. *Proceedings of the Sixth International Symposium on Heavy Vehicle Weights and Dimensions*, 1-10. Saskatoon, Saskatchewan, Canada.
- De Pont J.J., Baas P.H., Latto D.J. 2002a. Improving the safety of a log transport fleet, *International Large Truck Safety Symposium*, Knoxville, Tennessee, USA.
- De Pont J.J., Baas P.H., Mueller, T. H. 2002b. “Quick and Dirty” methods for estimating heavy vehicle stability. *International Large Truck Safety Symposium*, Knoxville, Tennessee, USA.
- De Pont, J.J., Baas, P.H. Hutchinson, D.N. and Kalasih, D. 2002c, Including performance measures in dimensions and mass regulations. *Proceedings of the Seventh International Symposium on Heavy Vehicle Weights and Dimensions*, 349-358. Delft, The Netherlands.
- De Pont, J.J., Hutchinson, D.N., Baas, P.H. and Kalasih, D. 2004, Implementing a roll stability requirement: issues, problems and results. *Proceedings of the Eighth International Symposium on Heavy Vehicle Weights and Dimensions*. Johannesburg, South Africa.
- De Pont J.J., Baas P.H. and Wilshier, W. 2006. Safety Gains in Log Transport in New Zealand, *Proceedings of the Ninth International Symposium on Heavy Vehicle Weights and Dimensions*. State College, Pennsylvania, USA.
- De Pont, J.J. 2010. *The development of pro-forma over-dimension vehicle parameters*. TERNZ Ltd., Auckland, New Zealand.
- De Pont. J.J. 2012. High productivity motor vehicles – New Zealand’s approach. *Proceedings of the Twelfth International Symposium on Heavy Vehicle Transport Technology*. Stockholm, Sweden.
- De Saxe, C.C. 2012. *Performance-Based Standards for South African Car-Carriers*. Dissertation (M.Sc.Eng.). University of the Witwatersrand, Johannesburg, South Africa.
- De Saxe, C.C. 2013a. *PBS analysis –Renault Midlum 280.18 + Lohr SHR ZA semitrailer car-carrier combination*. Confidential report for Lohr Transport ZA. CSIR Built Environment, Pretoria, South Africa.
- De Saxe, C.C. 2013b. *PBS analysis –Renault Midlum 280.18 + Rolfo Blizzard semitrailer car-carrier combination*. Confidential report for Rolfo South Africa. CSIR Built Environment, Pretoria, South Africa.
- De Saxe, C.C. and Kienhöfer, F. 2012. *PBS analysis – Unipower (Natal) Maxiporter Mk3 truck and tag trailer car-carrier combination*, Rev. 3. Confidential report for Unipower (Natal). University of the Witwatersrand, Johannesburg, South Africa.
- De Saxe, C.C. and Kienhöfer, F. 2013. *PBS analysis – Unipower (Natal) Flexiporter Mk2 tractor and semitrailer car-carrier combination*, Rev. 2. Confidential report for Unipower (Natal). CSIR Built Environment, Pretoria, South Africa.

- De Saxe, C.C., Kienhöfer, F. and Nordengen, P.A. 2012. Tail swing performance of the South African car-carrier fleet. *Proceedings of the Twelfth International Symposium on Heavy Vehicle Transport Technology*. Stockholm, Sweden.
- De Saxe, C.C. and Nordengen, P.A. 2013a. *PBS analysis – Lohr MHR 3.30 AS D1 + HER 2.03 XS car-carrier combination with EC16303 loading*. Confidential report for Lohr Transport ZA. CSIR Built Environment, Pretoria, South Africa.
- De Saxe, C.C., Nordengen, P.A. and Kienhöfer, F. 2013b. A Performance-Based Standards scheme to regulate car-carriers in South Africa. *Proc. 32nd Southern African Transport Conference*. Pretoria, South Africa.
- De Saxe, C.C. and Roux, M.P. 2013a. *Bridge and road wear impact analysis of proposed PBS interlink combination for container transport*. Confidential Report for Momentum Logistics. CSIR Built Environment, Pretoria, South Africa.
- De Saxe, C.C. and Roux, M.P. 2013b. *Bridge and road wear impact analysis of proposed PBS 185 T BAB-quad road train*. Confidential Report for Unitrans Mining. CSIR Built Environment, Pretoria, South Africa.
- De Saxe, C.C. and Roux, M.P. 2013c. *Bridge and road wear impact analysis of proposed 73-tonne PBS B-double Tautliner combination*. Confidential Report for Anderson Transport. CSIR Built Environment, Pretoria, South Africa.
- De Saxe, C.C., Roux, M.P. and Nordengen, P.A. 2013. *Bridge and road wear impact analysis of proposed PBS truck and drawbar-trailer combination for timber transport*. Confidential Report for Timbernology. CSIR Built Environment, Pretoria, South Africa.
- Dessein, T. and Kienhöfer, F. 2011. *PBS analysis – RBM side-tipping BAB-quad road train*. Confidential report. University of the Witwatersrand, Johannesburg, South Africa.
- DoT. 1996. *TRH4: Structural design for flexible pavements for inter-urban and rural roads*. Technical Recommendations for Highways. National Department of Transport, South Africa.
- DoT. 2003. *National Road Traffic Act No. 93 of 1996 (as updated up to the National Road Traffic Amendment Act, No. 20 of 2003 and Government Gazette 25541, 2003)*. National Department of Transport, South Africa.
- DoT. 2005. *National Freight Logistics Strategy*. Department of Transport, Pretoria, South Africa.
- DoT. 2010. *TRH11: Dimensional and mass limitations and other requirements for abnormal load vehicles*, 8th ed. Department of Transport, Pretoria, South Africa.
- DoT. 2013. *National Road Traffic Regulations No. R.225 of 2000 (as amended up to the National Road Traffic Amendment Act, No. 64 of 2008 and Government Gazette 36862, 2013)*. National Department of Transport, South Africa.

- Di Cristoforo, R. *et al.* 2003. *Performance assessment of intermodal container skels*. Roaduser Systems Report RUS-03-856-01-03. Melbourne, Australia.
- Di Cristoforo, R. 2004. Innovative vehicles designed to Australian Performance-Based Standards. *Proceedings of the Eighth International Symposium on Heavy Vehicle Weight and Dimensions*. Johannesburg, South Africa.
- ECE. 2001. *Uniform provisions concerning the approval of tank vehicles of categories N and O with regard to rollover stability*. Regulation No. 111, United Nations, Geneva, Switzerland.
- Edgar, J. 1995. Regulating Heavy Vehicle Safety in New Zealand using Performance Based Standards, *Proceedings of the Fourth International Symposium on Heavy Vehicle Weights and Dimensions*, 115-120. UMTRI, Ann Arbor, Michigan, USA.
- Edgar J. 2004. Development of Performance Standards for Australian Heavy Vehicles. *Proceedings of the Eighth International Symposium on Heavy Vehicle Weights and Dimensions*. Johannesburg, South Africa.
- Efron, A. "Personal communication". 22 October 2013.
- Elphinstone. 2003. *Timber transport trailer applications*. Elphinstone Engineering. Triabunna, Tasmania, Australia.
- European Parliament. 2013. *Draft report on the maximum authorised dimensions in national and international traffic and the maximum authorised weights in international traffic*. European Parliament, Committee on Transport and Tourism. Draft report 2013/0105(COD). Brussels, Belgium.
- Ervin, R.D. and Guy, Y. 1986a. *The Influence of Weights and Dimensions on the Stability and Control of Heavy Duty Trucks in Canada - Volume I: Technical Report*. Report UMTRI-86-35/I. CCMTA/RTAC Vehicle Weights and Dimensions Study. University of Michigan Transportation Research Institute, Ann Arbor, Michigan, USA.
- Ervin, R.D. and Guy, Y. 1986b. *The Influence of Weights and Dimensions on the Stability and Control of Heavy Duty Trucks in Canada – Volume II: Appendices A-B*. Report UMTRI-86-35/II. CCMTA/RTAC Vehicle Weights and Dimensions Study. University of Michigan Transportation Research Institute, Ann Arbor, Michigan, USA.
- EPA. 2013. Green Power Equivalency Calculator Methodologies. [Internet] United States Environmental Protection Agency. Available from: <http://www.epa.gov/greenpower/pubs/calcmeth.htm>. [Accessed: 19 November 2013]
- Fepke, E., Gopalakrishna, D. and Woodrooffe, J. 2006a. Performance-Based Oversize and Overweight Permitting System. *Proceedings of the 85th Transport Research Board Annual Meeting*. Washington, D.C., USA.
- Fepke, E., Gopalakrishna, D. and Woodrooffe, J. 2006b. Conceptual Framework for a Performance-Based Oversize and Overweight Permitting System. *Proceedings of the*

- Ninth International Symposium on Heavy Vehicle Weights and Dimensions*. State College, Pennsylvania, USA.
- FERIC. 1998. *Western Log Truck Configurations Study*. FERIC Contract Report No. CR-98-03-15. Forest Engineering Research Institute of Canada, Pointe-Claire, Canada.
- Gagne, R.E. 1986. Graphic Representation of Heavy Vehicle Computer Simulation Model Output: A 3-D Animation Package for Computer Models, *CCMTA/RTAC Vehicle Weights and Dimensions Study Technical Report Volume 15*. Roads and Transportation Association of Canada, Ottawa, Canada.
- Germanchev, A. and Chong, L. 2011. *Performance assessment of Unitrans side-tipping BAB-quad road train with dual tyres*. Confidential report HV004607. ARRB Group, Melbourne, Australia.
- Good, D., Robinson, J.B.L., Sparks, G. and Neudorf, R. 1991. *The Effect of Vehicle Length on Traffic on Canadian Two-lane, Two-way Roads*. Roads and Transportation Association of Canada, Ottawa, Canada.
- HMSO. 1972. *The Public Service Vehicles (Conditions of Fitness, Equipment and Use)*, Regulation No 6 Stability. London, United Kingdom.
- Johnston, M. and Bruzsa, L. 2008. Development of an Innovative Steerable Double Extendable Trailer under Performance Based Standards (PBS). *Proceedings of the Tenth International Conference on Heavy Vehicles*, 97-108. Wiley. Paris, France.
- Jokai, R. 2006. British Columbia log hauling configurations: maximum weights and dimensions guide, September 2006. Advantage Vol. 7 No. 17. Vancouver, Canada.
- Jung, F.W. 1969. *Simplified Design Live Load Patterns for Use in Controlling Vehicle Weights on Bridges*. Report RR 149. Ontario Department of Transportation and Communications, Toronto, Canada.
- Jung, F.W. and Witecki, A.A. 1971. *Determining the Maximum Permissible Weights of Vehicles on Bridges*. Report RR 175. Ontario Department of Transportation and Communications, Toronto, Canada.
- Kienhöfer, F., Dessen, T. and Nordengen, P.A. 2012. The PBS assessment of a South African bi-articulated bus design. *Proceedings of the Twelfth International Symposium on Heavy Vehicle Transport Technology*, Stockholm, Sweden.
- Kienhöfer, F. 2013. *Safety analysis of a proposed MAN bi-articulated bus (model HB3)*. Confidential report. University of the Witwatersrand, Johannesburg, South Africa.
- Killian, N.A., Rademeyer, I.M. and Richter, W. 2008. Deployment of ITS to address vehicle overloading in Gauteng. *Proceedings of the Eighth International Symposium on Heavy Vehicle Transport Technology*, Johannesburg, South Africa.

- Koniditsiotis, C. and Karl, C.A. 2010. Intelligent Access Program update on heavy vehicle monitoring. *Proceedings of the Eleventh International Symposium on Heavy Vehicle Transport Technology*, Melbourne, Australia.
- Levene, H. 1960. *Robust tests for equality of variances*. Contributions to Probability and Statistics (Edited by I. Olkin, *et al.*), Stanford Univ. Press, Stanford, Chapter 25. pp. 278–292
- Lofröth, C., Larsson, L., Enström, J., Cider, L., Svenson, G., Aurell, J., Johannson, A. and Asp, T. 2012. ETT – a modular system for forest transport: a three-year roundwood haulage test in Sweden. *Proceedings of the Twelfth International Symposium on Heavy Vehicle Transport Technology*, Stockholm, Sweden.
- LTSA, 2002. *Land Transport Rule: Vehicle Dimensions and Mass 2002, Rule 41001*. [Internet]. Land Transport Safety Authority, Wellington, New Zealand. Available from: <http://www.nzta.govt.nz/resources/rules/vehicle-dimensions-and-mass-2002-index.html>. [Accessed: 27 October 2013].
- McIntyre, K., and Moore, B. 2002. *National Road Transport Compliance and Enforcement Reforms: On the Road to a New National Culture of Compliance*. Paper presented to the Australian Institute of Criminology's Current Issues in Regulation: Enforcement and Compliance Conference, Melbourne, Australia.
- McIntyre, K. 2005. *Chain of Responsibility: Achieving Truck and Bus Compliance in Australia*. Paper presented to the International Truck and Bus Safety and Security Symposium. Virginia, USA.
- mePADS. 2008. *Mechanistic Empirical Pavement Design and Analysis Software*. CSIR Built Environment (CSIR BE), Pretoria, South Africa. See website: <http://asphalt.csir.co.za/samdm/>
- Moore, B. 2007. An Integrated Approach to the Regulation of Heavy Vehicles. *Proceedings of the 23rd World Road Congress*. Paris, France.
- Mueller, T. H., de Pont, J. J. and Baas, P. H. 1999. *Heavy vehicle stability versus crash rates*. TERNZ, Manukau City, New Zealand.
- NCHRP. 2008. *Review of Canadian experience with large commercial motor vehicles*, NCHRP Project 8-63, Washington D.C., USA.
- NHVR. 2013. *NHVR: Our history* [Internet] National Heavy Vehicle Regulator. Brisbane Australia. Available from: http://www.nhvr.gov.au/about-us/who-we-are/our_history. [Accessed 27 October 2013].
- Nix, F.P. *et al.* 1996. *Assessment of the Impact of Changes in Vehicle Configurations on Ontario's Industry*, Report for Ontario Ministry of Transportation, Canada.

- Nordengen, P.A. 1998. A new era of overloading control in South Africa. *Proceedings of the Fifth International Symposium on Heavy Vehicle Weights and Dimensions*, Maroochydore, Australia.
- Nordengen, P.A. 2009. *Performance-Based Standards for heavy vehicles: Monitoring report on two PBS vehicles operating in the forestry industry: November 2007 to July 2008*. CSIR Built Environment, Pretoria, South Africa.
- Nordengen, P.A. 2010. Monitoring results of two PBS demonstration vehicles in the forestry industry in South Africa. *Proceedings of the Eleventh International Symposium on Heavy Vehicle Transport Technology*. Melbourne, Australia.
- Nordengen, P.A. 2012. Monitoring results of PBS vehicles in South Africa in terms of Productivity, Safety and Road Wear Performance. *Proceedings of the Twelfth International Symposium on Heavy Vehicle Transport Technology*, Stockholm, Sweden.
- Nordengen, P.A. and Hellens, M. 1995. A system for monitoring overloaded vehicles. *Proceedings of the Fourth International Symposium on Heavy Vehicle Weights and Dimensions*, Ann Arbor, Michigan, USA.
- Nordengen, P.A. and Oberholzer, F. 2006. A self-regulation initiative in heavy vehicle transport to address road safety, accelerated road deterioration and transport productivity in South Africa. *Proceeding of the Ninth International Symposium on Heavy Vehicle Weights and Dimensions*, Penn State University, State College, USA.
- Nordengen, P.A., Prem, H. and Mai, L. 2008. An initiative to introduce a performance-based standards (PBS) approach for heavy vehicle design and operations in South Africa, *Proceedings of the Tenth International Symposium on Heavy Vehicle Transport Technology*, Paris, France.
- Nordengen, P.A., Prem, H. and Lyne, P.W.L. 2009. *Performance-based standards (PBS) vehicles for transport in the agricultural sector*. Sugar Cane International, Vol. 27, No. 2. Tunbridge Wells, U.K.
- Nordengen, P.A. and Roux, M.P. 2013. Evaluation of a Performance-Based Standards approach to heavy vehicle design to reduce pavement wear. *Proceedings of the 17th International Road Federation World Meeting*, Riyadh, Saudi Arabia.
- NPI. 2006. *Road Transport Management System Five-Year Strategy*. National Productivity Institute, Midrand, South Africa.
- NRTC. 1999a. *Performance Based Standards for Heavy Vehicles in Australia: Field of Performance Measures*. Prepared by Sweatman, P, Ramsay, E, Lambert, J and Prem, H. National Road Transport Commission, Melbourne, Australia.
- NRTC. 1999b. *Performance Based Standards for Heavy Vehicles: Assembly of Case Studies*. Prepared by Prem, H., Ramsay, E and McLean, J; ARRB Transport Research. National Road Transport Commission, Melbourne, Australia.

- NRTC. 2000a. *Performance Based Standards Policy Framework for Heavy Vehicle Regulation*. Discussion paper. National Road Transport Commission, Melbourne, Australia.
- NRTC. 2000b. *Specification of Performance Standards and Performance of the Heavy Vehicle Fleet*. Discussion Paper. NRTC/Austrroads Project A3 and A4. National Road Transport Commission, Melbourne, Australia.
- NRTC. 2000c. *Performance-Based Standards for Heavy Vehicle Regulation*. Working paper on legal, regulatory and compliance issues. National Road Transport Commission, Melbourne, Australia.
- NRTC. 2001a. *Performance Based Standards Policy Framework for Heavy Vehicle Regulation: Regulatory Impact Statement*. National Road Transport Commission, Melbourne, Australia.
- NRTC. 2001b. *Definition of Potential Performance Measures and Initial Standards*. Discussion paper prepared by Prem, H., Ramsay, E., McLean, J., Pearson, R.A., Woodrooffe, J. and De Pont, J. NRTC/Austrroads Project A3 and A4. National Road Transport Commission, Melbourne, Australia.
- NRTC. 2001c. *Report on Initial Selection of Potential Performance Measures*. Discussion paper prepared by Prem, H., Ramsay, E., McLean, J., Pearson, R.A., De Pont, J., Woodrooffe, J. and Yeo, D. NRTC/Austrroads Project A3 and A4. National Road Transport Commission, Melbourne, Australia.
- NRTC. 2001d. *Dimension and Mass Characterisation of the Australian Heavy Vehicle Fleet*. Prepared by Ramsay, E., Prem, H. and Pearson, R.A. NRTC/Austrroads Project A3 and A4. National Road Transport Commission, Melbourne, Australia.
- NRTC. 2001e. *Comparison of Modelling Systems for Performance-Based Assessments of Heavy Vehicles*. Working paper prepared by Prem, H., Ramsay, E., De Pont, J., McLean, J. and Woodrooffe, J. National Road Transport Commission, Melbourne, Australia.
- NRTC. 2002a. *An Overview of Performance Based Standards Regulatory and Compliance processes*. National Road Transport Commission, Melbourne, Australia.
- NRTC. 2002b. *Steerable axles to improve productivity and access*. Prepared by Coleman, B. and Sweatman, P. National Road Transport Commission, Melbourne, Australia.
- NRTC. 2002c. *Performance Characteristics of the Australian Heavy Vehicle Fleet*. Working paper prepared by Prem, H., de Pont, J., Pearson, R.A. and McLean, J. NRTC/Austrroads Project A3 and A4. National Road Transport Commission, Melbourne, Australia.
- NRTC. 2002d. *Truck Safety Benchmarking Study*. Prepared by Harworth, N., Vulcan, P. and Sweatman, P. National Road Transport Commission, Melbourne, Australia.
- NRTC. 2003a. *Performance-Based Standards: Regulatory and Compliance Processes*. Discussion Paper. National Road Transport Commission. Melbourne, Australia.

- NRTC. 2003b. *PBS Safety Standards for Heavy Vehicles*. Discussion paper prepared by Prem, H., McLean, J. and Edgar, J. NRTC/Austrroads Project A3 and A4. National Road Transport Commission, Melbourne, Australia.
- NRTC. 2003c. *PBS infrastructure protection standards for heavy vehicles*. Discussion paper. NRTC/Austrroads Project A3 and A4. National Road Transport Commission, Melbourne, Australia.
- NRTC. 2003d. *Performance-Based Standards Phase A Standards and Measures Regulatory Impact Statement*. Prepared by Economic Associates Pty Ltd, Pearsons Transport Resource Centre Pty Ltd, RT Dynamics Pty Ltd. Project Managed by: ARRB Transport Research Ltd. National Road Transport Commission, Melbourne, Australia.
- NRTC. 2003e. *Road Transport Reform (Compliance and Enforcement) Bill. Regulatory Impact Statement*. Prepared by Jaguar Consulting Pty Ltd. National Road Transport Commission, Melbourne, Australia.
- NRTC. 2003f. *Road Transport Reform (Compliance and Enforcement) Bill. Model Provisions*. National Road Transport Commission, Melbourne, Australia.
- NRTC. 2004a. *Interim PBS Road Classification Guidelines*. Prepared by ARRB Transport Research Pty Ltd. National Road Transport Commission, Melbourne, Australia.
- NTC. 2005a. *Regulatory Impact Statement: Performance-Based Standards for Heavy Vehicle Regulation: Proposed Regulatory Framework and Processes*. Prepared by Economic Associates Pty Ltd, Pearsons Transport Resource Centre Pty Ltd in association with the National Transport Commission, Melbourne, Australia.
- NTC. 2005b. *Rules for Assessment of Potential PBS Vehicles – Discussion Paper and Draft Rules* prepared by Pearsons Transport Resource Centre Pty Ltd, Mechanical System Dynamics Pty Ltd and ARRB Group Ltd. National Transport Commission, Melbourne, Australia.
- NTC. 2006a. *Administrative Guidelines, Rules and Codes for Operation of Performance-Based Standards Vehicles: Vehicle Assurance and Operating Rules*. Prepared by Prem, H., Pearson, R.A. and Gardner, B. National Transport Commission, Melbourne, Australia.
- NTC. 2006b. *Administrative Guidelines, Rules and Codes for Operation of Performance-Based Standards Vehicles: Operator Certification Guidelines*. Prepared by Pearson, R.A., Prem, H. and Gardner, B. National Transport Commission, Melbourne, Australia.
- NTC. 2006c. *Administrative Guidelines, Rules and Codes for Operation of Performance-Based Standards Vehicles: Compliance Assurance Guidelines*. Prepared by Pearson, R.A., Prem, H. and Gardner, B. National Transport Commission, Melbourne, Australia.
- NTC. 2006d. *Administrative Guidelines, Rules and Codes for Operation of Performance-Based Standards Vehicles: Discussion paper*. Prepared by Pearson, R.A., Prem, H. and Gardner, B. National Transport Commission, Melbourne, Australia.

- NTC. 2007a. *Performance Based Standards Scheme: Network Classification Guidelines*. National Transport Commission, Melbourne, Australia.
- NTC. 2007b. *Performance Based Standards Scheme: Assessor Accreditation Rules*. National Transport Commission, Melbourne, Australia.
- NTC. 2007c. *Performance Based Standards Scheme: Vehicle Certification Rules*. National Transport Commission, Melbourne, Australia.
- NTC. 2007d. *Performance Based Standards Scheme: Guidelines for Determining National Operating Conditions*. National Transport Commission, Melbourne, Australia.
- NTC. 2007e. *Performance Based Standards Scheme: Review Panel Business Rules*. National Transport Commission, Melbourne, Australia.
- NTC. 2008a. *Performance based standards scheme – The standards and vehicle assessment rules*. National Transport Commission, Melbourne, Australia.
- NTC. 2008b. PBS Case studies [Internet]. National Transport Commission, Melbourne, Australia. Available from: <http://www.ntc.gov.au/viewpage.aspx?page=A023114004005800200>. [Accessed: 15 July 2008]
- NZTA, 2010. *Vehicle Dimensions and Mass Amendment 2010 Rule 41001/5*, [Internet]. New Zealand Transport Agency, Wellington New Zealand. Available from: <http://www.nzta.govt.nz/resources/rules/vehicle-dimensions-and-mass-amendment-2010.html> [Accessed 27 October 2013].
- OAG. 2005. *Progress in Implementing Key Recommendations of the 1996 Transport Committee Inquiry into Truck Crashes*. Office of the Auditor-General, Wellington, New Zealand.
- OECD. 1997. *Report to Ministers on Regulatory Reform*. OECD, Paris, France.
- OECD. 2005. *Performance-based standards for the road sector*. OECD, Paris, France.
- OECD. 2007. *Working Group on Heavy Vehicles: Regulatory, Operational and Productivity Improvements: Draft Terms of Reference*. Joint OECD/ECMT Transport Research Committee. OECD, Paris, France.
- OECD. 2011. *Moving Freight with Better Trucks: Improving Safety, Productivity and Sustainability*. ISBN 978-92-821-0293-0. OECD Publishing. Paris, France.
- Parker, S.P.S., Amlin, E.J. and Hart, D.V. 1998. *Steering Evaluations of a Tridem Drive Tractor in Combination with Pole Trailers*. Forest Engineering Research Institute of Canada, Pointe-Claire, Canada.
- Pearson R.A. and Leyden P. 2004. Performance-Based Standards: Challenges in Developing Infrastructure Protection Standards. *Proceedings of the Eighth International Symposium on Heavy Vehicle Weights and Dimensions*. Johannesburg, South Africa.
- Peters, R. and Stevenson, J. 2000. Regulating Heavy Vehicles in Australasia using a Performance-Based Standards approach. *Proceedings of the Sixth International Symposium on Heavy Vehicle Weights and Dimensions*, 289-300. Saskatoon, Canada.

- Prem, H. and Mai, L. 2006. *PBS analysis of two concept vehicles for timber transport in South Africa*. Confidential MSD report 200605-28-02. Mechanical System Dynamics, Melbourne, Australia.
- Prem, H., Mai, L. and Atley, K. 2006a. Application of Trackaxle® to Multi-Combination Vehicles. *Proceedings of the Ninth International Symposium on Heavy Vehicle Weights and Dimensions*. State College, Pennsylvania, USA.
- Prem, H., Mai, L. and Bruzsa, L. 2006b. Tilt Testing of Two Heavy Vehicles and Related Performance Issues. *Proceedings of the Ninth International Symposium on Heavy Vehicle Weights and Dimensions*. State College, Pennsylvania, USA.
- Prem, H., Mai, L. and Davey, G. 2008. A New Steerable Wheel System for Road Transport Applications. *Proceedings of the Tenth International Conference on Heavy Vehicles*, 413-428. Wiley. Paris, France.
- Rolland, D., Pearson, R.A. and Edgar, J. 2006. Performance-Based Standards – Recent Developments in Australia. *Proceedings of the Ninth International Symposium on Heavy Vehicle Weights and Dimensions*. State College, Pennsylvania, USA.
- Roux, M.P. and De Saxe, C.C. 2013. *Bridge and road wear impact analysis of proposed PBS B-double side-tipper combination*. Confidential Report for Barloworld Logistics Africa. CSIR Built Environment, Pretoria, South Africa.
- Roux, M.P., De Saxe, C.C. and Nordengen, P.A. 2012a. *Bridge and road wear impact analysis of proposed PBS truck and trailer combination for transport of timber*. Confidential Report for Zabalaza Hauliers. CSIR Built Environment, Pretoria, South Africa.
- Roux, M.P., De Saxe, C.C. and Nordengen, P.A. 2012b. *Bridge and road wear impact analysis of proposed PBS interlink combination*. Confidential Report for Ngululu Bulk Carriers. CSIR Built Environment, Pretoria, South Africa.
- Roux, M.P., De Saxe, C.C. and Nordengen, P.A. 2012c. *Bridge and road wear impact analysis of proposed PBS timber truck and full-trailer vehicles*. Confidential Report for Mondi. CSIR Built Environment, Pretoria, South Africa.
- Roux, M.P. and Nordengen, P.A. 2010. *Study on axle loads; turning circles; and lane widths for freight vehicles in sub-Saharan Africa: Final report*. CSIR Built Environment, Pretoria, South Africa.
- Roux, M.P. and Nordengen, P.A. 2013. *Bridge and road wear impact analysis of proposed PBS bus combinations*. Confidential Report for Buscor. CSIR Built Environment, Pretoria, South Africa.
- RTAC. 1980. *Vehicle Weights and Dimensions - Bridge Capacity Study*, Roads and Transportation Association of Canada, Ottawa, Canada.
- RTAC. 1986. *Vehicle Weights and Dimensions Study Technical Steering Committee Report*. Roads and Transportation Association of Canada, Ottawa, Canada.

- RTAC. 1987. *Recommended Regulatory Principles for Interprovincial Heavy Vehicle Weights and Dimensions*, CCMTA/RTAC Vehicle Weights and Dimensions Study Implementation Committee Report. Roads and Transportation Association of Canada, Ottawa, Canada.
- RTAC. 1988. *Memorandum of Understanding on Interprovincial Heavy Vehicle Weights and Dimensions*. Roads and Transportation Association of Canada, Ottawa, Canada.
- RTAC. 1992. *The Effect of Vehicle Length on Traffic on Canadian Two-lane, Two-way Roads*, Committee Report. Roads and Transportation Association of Canada, Ottawa, Canada.
- RTMS, 2012. *Road Transport Management System (RTMS) and the Smart Truck/Performance Based Standards (PBS) pilot project*. Progress report to Minister of Transport. RTMS National Steering Committee, Pretoria, South Africa.
- SAS. 2011. SAS/STAT software, Version 9.3 of the SAS system for Windows. SAS Institute Inc. Cary, NC, USA.
- Sharma, S. 2013. *The Effective Evaluation of Truck Safety for an Alternative Parallel South African PBS Legislation*. Dissertation (M.Sc.Eng.). University of the Witwatersrand, Johannesburg, South Africa.
- Standards South Africa. 2007. ARP 067-1: Road Transport Management Systems: Part 1: Operator Requirements – Goods. ISBN: 978-0-626-19331-7. SABS, Pretoria, South Africa.
- Steyn, W., Nordengen, P.A., Roux, M., Sallie, I. and Kekwick, S. 2004. *National overload control strategy (CR-2002/67)*. National Department of Transport, South Africa. CSIR Transportek, Pretoria, South Africa.
- Sweatman, P, Woodrooffe, J and Blow, P. 1998. Use of engineering performance in evaluating size and weight limits. *Proceedings of the Fifth International Symposium on Heavy Vehicle Weights and Dimensions*, 161-176. Queensland, Australia.
- Sweatman, P.F., Di Cristoforo, R. and Kalasih, D. 2003a. *Benchmarking heavy vehicle productivity and safety performance*. Roaduser Systems Report RUS-03-898-01-01. Melbourne, Australia.
- Sweatman, P.F., Coleman, M. and Di Cristoforo, R. 2003b. *Evaluation of an active-steering triaxle group (Trackaxle)*, Roaduser Systems Report RUS-03-1000-01-03. Melbourne, Australia.
- Theyse, H.L., De Beer, M. and Rust, F.C. 1996. Overview of the South African Mechanistic Pavement Design Analysis Method. Paper No. 96-1294. *Proceedings of the 75th Annual Transportation Research Board Meeting*, Washington, D.C., USA.
- Thorogood, R. L. 2009. *Performance based analysis of current South African semi-trailer and B-double trailer designs*. Thesis (M.Sc.Eng.). University of KwaZulu-Natal, Durban, South Africa.

- TRB. 2002. *Regulations of Weights, Lengths, and Widths of Commercial Motor Vehicles*. Special Report 267. National Research Council, Transportation Research Board. Washington, D.C., USA.
- US DoT. 2000. *Comprehensive Truck Size and Weight (CTS&W) Study*. FHWA, U.S. Department of Transportation, Washington, D.C., USA.
- Vuong, B. Tepper, S. and Sharp, K. 2002. *Performance-Based Specifications for Heavy Vehicles. Evaluation of requirements for Vertical Loading*. ARRB Transport Research Ltd. Published as Appendix B in PBS Infrastructure Protection Standards for Heavy Vehicles, Discussion Paper. January 2003. National Road Transport Commission. Melbourne, Australia.
- White, D. M. and Baas, P. H. 1993. Improving the safety of heavy vehicles in New Zealand through performance-based regulations. *Proceedings of the 26th ISATA International Symposium*, Aachen, Germany.
- Winkler, C.B., Blower, D., Ervin, R. D. and Chalasani, R.M. 2000. *Rollover of heavy commercial vehicles*. The University of Michigan Transport Research Institute. SAE Research Report. Ann Arbor, Michigan, USA.
- Wong, J.Y. and El-Gindy, M. 1986. A comparison of Various Computer Simulation Models for Predicting the Lateral Dynamic Behaviour of Articulated Vehicles, *CCMTA/RTAC Vehicle Weights and Dimensions Study Technical Report Volume 16*. Roads and Transportation Association of Canada, Ottawa, Canada.
- Woodrooffe, J.H.F., LeBlanc, P.A. and El-Gindy, M. 1986. *Technical Analysis and Recommended Practice for the Double Drawbar Dolly Using Self-steering Axles*. Roads and Transportation Association of Canada, Ottawa, Canada.
- Woodrooffe, J.H.F., LeBlanc, P.A. and LePiane, K.R. 1986. The Effect of Suspension Variations on the Dynamic Wheel Loads of a Heavy Articulated Vehicle, *CCMTA/RTAC Vehicle Weights and Dimensions Study Technical Report Volume 11*. Roads and Transportation Association of Canada, Ottawa, Canada.
- Woodrooffe, J.H.F., Burns, N, Johnson, D, Palmer, J and Smith, D. 1998. Constructive use of performance measures for improved vehicle safety and productivity. *Proceedings of the Fifth International Symposium on Heavy Vehicle Weights and Dimensions*, 161-176. Queensland, Australia.
- Woodrooffe, J.H.F., Glaeser, K-P. and Nordengen, P.A. 2010. Truck productivity, efficiency, energy use and CO₂ output – international performance benchmarking. *Proceedings of the 89th Annual Transportation Research Board Meeting*, Washington, D.C., USA.

APPENDIX A

Proposed parameters for monitoring PBS and baseline vehicles

	MEASUREMENT	UNIT	WHEN/WHO	INFO	COMMENTS	TASKS
LOAD AND FUEL CONSUMPTION INFORMATION						
1	Fuel consumption	ℓ/100 km	At every event by haulier	All fuel used during the month, km reading when filled, and date when filled.	<ul style="list-style-type: none"> ● 2 PBS vehicles run on < 10 routes. Map need to show PBS routes [road classes (national, provincial road, etc.), gravel/tar, route specs (grades, horizontal curvatures). ● Up to 6 control vehicles should be measured (at least 2 new vehicles). 	<ul style="list-style-type: none"> ● Determine which routes will be used. ● Obtain grade and curve information for routes (HTM or grower).
2	Payload	kg	At every event by haulier & weighbridge	Weights for every trip from onboard weighing & Mill weighbridge, and date		
3	Axle/Axle unit loads	kg	Weekly by the weighbridge	Determine the load on each axle or axle group by using deductive weighing at the mill weighbridge.	Onboard weighing results will be calibrated against weighbridge information.	
4	Fuel efficiency factor (FEF)	t/100 ℓ	Monthly calculation by research team	Calculate the fuel efficiency of the control & PBS vehicles.	<ul style="list-style-type: none"> ● This will give an indication of the tons moved per 100 litres fuel used. ● Calculation: (Monthly tons moved/monthly fuel used)*100 	

	MEASUREMENT	UNIT	WHEN/WHO	INFO	COMMENTS	TASKS
5	Payload efficiency factor (PEF)		Monthly calculation by research team	Calculate the payload efficiency of the control & PBS vehicles.	<ul style="list-style-type: none"> ● Calculation: (Average monthly payload/GCM)*100 	
TRIP INFORMATION						
6	Lead distance	km	Every trip by haulier	Measure km travelled, origin and destination	<ul style="list-style-type: none"> ● Could be measured with onboard management system ● Must specify which route was travelled. Classify roads into routes (A, B, C, etc.) 	
7.	Duration of trip (Turnaround time)	hr	Every trip by haulier	Measure <ul style="list-style-type: none"> ● Loading time ● Duration of trip ● Off-loading time ● Duration back 	<ul style="list-style-type: none"> ● Could be measured with onboard management system ● Must specify which route was travelled 	
7	Average speed (laden)	km/h	Every trip by haulier	onboard management system		
8	Average speed (empty)	km/h	Every trip by haulier	onboard management system		
SERVICES						
9	Major Service cost	R	Every service by haulier	service book		
10	Minor Service cost	R	Every service by haulier	service book		

	MEASUREMENT	UNIT	WHEN/WHO	INFO	COMMENTS	TASKS
ACCIDENTS, INCIDENTS, BREAKDOWNS						
11	Accidents/Incidents	R	Every occurrence by haulier & grower company	<ul style="list-style-type: none"> ● Actual cost of incidents ● Estimate the cost of near misses ● Reason for incident 	Obtain the historical data of accidents, look at trends. This information will provide a good idea on what areas focus is needed on. Must also include near misses.	Obtain accident info from Sappi and Mondi
12	Breakdowns	R,	Every occurrence by haulier	<ul style="list-style-type: none"> ● Actual cost of breakdowns ● Reason for breakdown 		
TYRE LIFE AND COSTS						
13	Number of tyres used: Truck Tractor (steering and drive) & Trailer	#, km	Every occurrence by haulier	Keep track of every tyre that are replaced, and km travelled with each tyre	Determine average tyre life measure km when every tyre is fitted/scrapped <i>Question: Are tyres rotated?</i>	
14	Tread depth	mm	Every service by research team	Measure the tread depth of every tyre		
15	Tyre pressures (CTI)		Daily (record with CTI system) / weekly (recorded by haulier)	For CTI: Determine pressure Daily. Without CTI: Determine pressure weekly	At what pressures would the vehicles run? There are four conditions: Paved, unpaved, laden, un-laden. Specification for all conditions must be developed. Record CTI tire pressures continuously. Measure tyre pressures once per week.	FO to ask Des at what pressures they will be running the CTI. FO to ask Kilopascal if CTI can record data

	MEASUREMENT	UNIT	WHEN/WHO	INFO	COMMENTS	TASKS
LIFE-CYCLE OF FOUNDATION BRAKES						
16	Wear	mm	At every service by haulier / research team	Measure the amount of wear on the brakes		
17	Replacement	km	Every occurrence by haulier	How often are brakes replaced?		
SUSPENSION LIFE AND COSTS						
18	Maintenance	km	Every occurrence by haulier	How often are suspension units serviced/repaired?	Determine life-cycle costs of various types of suspensions (multi-leaf steel spring, airbag and shock absorbers)	
19	Replacement	km	Every occurrence by haulier	How often are suspension units replaced?		
COMPLAINTS						
20	Complaints from public, etc.		As it occurs by haulier, grower company and DOT	Log all complaints from the public, and other stakeholders	Complaints must be handled in association with KZN DOT – complaints to timber industry and DOT are combined.	

APPENDIX B

Smart Truck programme rules



SMART TRUCK PROGRAMME

RULES FOR THE DEVELOPMENT AND OPERATION OF SMART TRUCKS AS PART OF THE PERFORMANCE-BASED STANDARDS RESEARCH PROGRAMME IN SOUTH AFRICA

October 2013

Compiled by:

Smart Truck Committee and
CSIR Built Environment



1 Introduction

In most countries throughout the world, heavy vehicle use on the road network is controlled predominantly by prescriptive regulations. These regulations, in many cases, differ significantly from one country to another. Efforts in various parts of the world (including the SADC Region) to achieve regional harmonisation and effective road use have had limited success. Another approach is to consider performance-based standards (PBS); in this case standards specify the performance required from the operation of a vehicle on a network rather than prescribing how the specified level of performance is to be achieved. This approach allows more flexibility for vehicle designers to utilise innovative solutions and the latest available technology to meet the required performance standards with improved safety outcomes and more effective use of the road infrastructure. The PBS approach also allows a more optimum “match” between the PBS vehicle and the road infrastructure (roads and bridges) which it uses. Heavy vehicles operated under a PBS framework are typically limited to travel on a subset of the network to ensure protection of the road infrastructure and acceptable safety levels. As a result of initiatives in Australia, New Zealand and Canada, the application of performance-based standards in the heavy vehicle sector in South Africa was identified by the CSIR as a research area warranting Parliamentary Grant funding because of the potential benefits in terms of transport efficiency, road/vehicle safety and the protection of road infrastructure.

As part of the Smart Trucks research programme, a need was identified to design, manufacture and operate a number of PBS demonstration projects in South Africa in order to gain practical experience in the performance-based standards approach for heavy vehicles and to quantify and evaluate the potential safety and productivity benefits of this approach to road freight transport. The fleets of participating operators of these vehicles are required to be accredited through the Road Transport Management System (RTMS) self-regulation programme.

The vehicle performance standards that have been used to design PBS demonstration vehicles cover high and low speed directional and non-directional manoeuvres such as startability, gradeability, acceleration capability, frontal swing, tail swing, slow speed swept path, tracking ability on a straight path, static rollover threshold, rearward amplification, yaw damping and high speed transient off-tracking.

2 Application process

The following process is required to be followed in order for an interested party to participate in the Smart Trucks Programme.

2.1 Certification in terms of the Road Transport Management System (RTMS)

RTMS certification (in terms of the SABS Recommended Practice ARP-067 Part 1) of the fleet in which the proposed Smart Truck(s) will operate is required for a minimum of six months prior to the commissioning of the Smart Truck(s). This requirement is to ensure that the transport operator, and in particular the relevant fleet, is being managed and operated in accordance with prescribed minimum safety and loading standards.

2.2 Application for Operational Approval and Principle Approval (if required)

The first step in a Smart Truck demonstration project is to identify one or more concept designs and to identify the proposed routes on which the Smart Truck(s) would operate. The concept design must indicate key dimensions, axle and axle unit masses of the vehicles combination. If the proposed vehicle is a Level 2 or higher in terms of the Australian requirements for PBS vehicles, a detailed description of the route(s) on which the proposed vehicle will operate, must be provided i.e. the entire route(s) must be described from origin(s) to destination(s). Final approval of the application will be limited to the approved route(s).

Once the above information has been compiled, the applicant is required to submit a letter requesting Operational Approval to the relevant Provincial Abnormal Load Permit Office(s). Should one or more of the vehicles making up the Smart Truck vehicle combination not comply with the National Road Traffic Act Regulations, Principle Approval is also required from the national Department of Transport as per the Abnormal Load process. Copies of these letters of application must be submitted to the Chairman of the Smart Truck Review Panel.

Operational Approval is generally given for a period of five years, subject to the renewal of the annual Exemption Permits. This is to enable the operator to recover the capital investment of the Smart Truck. However, non-compliance of the permit conditions may result in the withdrawal of the Exemption Permit (see Annexure A).

2.3 Detail design and assessment

On receiving a letter of Operational Approval from all the relevant Provinces and a letter of Principle Approval from the national Department of Transport (if required), the applicant may proceed with a detail design of the proposed vehicle combination followed by a PBS assessment in terms of the Australian National Transport Commission's PBS assessment requirements. Should the proposed vehicle design not meet one or more of the required performance levels, one or more design modifications will be required in order for the vehicle combination to meet all the required performance levels. Besides the safety performance standards assessment, a road wear assessment and an assessment of the vehicle design in terms of the South African Abnormal Load bridge formula is required. Note: These infrastructure standards assessments should be done prior to the request for Operational Approval, so that the assessment reports can be submitted to the relevant Abnormal Load Permit Office(s) together with the letter requesting Operational Approval as part of the motivation for the project.

2.4 Smart Truck design approval

The final assessment reports together with the final vehicle design and proposed routes must be submitted to the Smart Trucks Review Panel for approval. The Review Panel may at its discretion invite one or more representatives of the applicant to attend a Review Panel meeting. Should the Review Panel not be entirely satisfied with the application, further information may be required from the applicant.

2.5 Final Operation Approval

Final operation approval is required from the relevant Provincial Abnormal Load Permit Office(s) once approval for the design has been issued by the Smart Truck Review Panel.

2.6 Vehicle manufacture

On receipt of the final operation approval, the applicant may proceed with the manufacture and purchase of the vehicle components in accordance with the approved design.

2.7 NaTIS registration

NaTIS registration and vehicle licensing processes should be followed once the vehicle combination is ready for operation.

2.8 Commissioning

Once the vehicle has been registered and licensed, a representative of the Provincial Abnormal Load Permit Office in which the vehicle is operated (needs discussion) will be required to verify the vehicle dimensions and other requirements such as Abnormal Load boards and warning lights in terms of the approved PBS design.

2.9 Operation

On successful commissioning of the vehicle combination, an Abnormal Load period permit will be issued by the relevant A/L Permit Office(s) for a maximum period of twelve (12) months. The period permit will be renewed annually subject to adequate compliance of the Smart Truck to the permit conditions.

2.10 Monitoring

Operational data as specified in Section 6 is required to be submitted to the relevant Abnormal Load Permit Office(s) as well as the CSIR on a monthly basis in order to monitor compliance as well as to evaluate the benefits of the Smart Trucks research programme demonstration projects. Live Satellite tracking links must be provided to Administration Staff on request.

Activity	Responsible person/group
1. RTMS certification	Operator/RTMS auditor
2. Concept design, proposed route(s)	Various (consignor, operator)
3. PBS application for operational approval (including route approval) and principle approval (if required)	Relevant A/L permit offices/national DoT/Smart Truck committee
4. Detail design	Trailer manufacturer/OEM
5. PBS assessment	PBS assessor (Australia or Wits)
6. PBS design approval	Smart Truck Review Panel
7. Final operational approval	A/L Permit office
8. Manufacture	Trailer manufacturer
9. NaTIS registration	SABS/NRCS/DOT
10. Commissioning	Certifier (road authority)
11. Operation and monitoring (see Section 3)	A/L Permit Office, auditor, CSIR

3 Vehicle design

The following features are required to be included in the vehicle design:

- ABS and EBS braking systems
- Retarders/intarders
- Side marker lights (truck/truck tractor and trailers)
- Xenon headlights
- Amber flashing light on the roof of the truck/truck tractor
- Abnormal load signs front & back
- Vehicle management system (for monitoring driver performance including speeding, harsh braking/acceleration, vehicle location)

The following features are available on some models of heavy vehicles and are recommended. One or more may become a requirement in the future.

- Rollover prevention system (ESC/ESP)
- Adaptive Cruise Control (Active distance control)
- Lane departure warning system
- Driver fatigue warning devices
- Tyre pressure monitoring and control
- Driver CAM

4 Operation

- Vehicle combination to be under the manufacturer's warranty at the time of the commissioning of the Smart Truck *i.e.* all vehicle components must be relatively new.
- Route classification – Route assessments are required to be done by a competent person (such as the driver trainer, Depot or SHEQ Manager) at regular intervals (at least bi-monthly) in order to monitor risk.
- Operation of Smart Trucks only on pre-defined and approved routes
- Vehicle tracking information to be provided to the DoT at least on a monthly basis (see Section 5)
- Speed restrictions: 80 km/hr but lower speed limits may be specified under the permit conditions for larger PBS vehicles at the discretion of the issuing authority.
- Headlights on when vehicle is in operation
- Following distance (between Smart Trucks): The driver must keep a minimum following distance of 100 m between consecutive Smart Trucks. Normal following distance requirements apply to all other vehicles.
- Vehicle maintenance requirements – tyres, suspension and brakes. Records to be kept of maintenance in terms of component manufacturer's requirements (RTMS requirement)
- Mass tolerance (0% on combination mass; 5% on axles/axle units)

5 Drivers

The following issues are considered important in terms of drivers of Smart Trucks:

- Selection criteria – Drivers must have a minimum of 3 years driving experience within the company and a minimum of 10 years' experience with driving an articulated vehicle. In the case where a driver displays an exceptional aptitude in terms of the on-board monitoring scorecard (e.g. exceeding a score of 95% over a six-month period) and his assessment by the training manager is exemplary, the three-year rule may be reduced to a minimum of one year.
- Driver hours are in accordance with the dangerous goods driver requirements
- Driver training - Evidence of frequent driver refresher training is required *i.e.* at least every six months in order to minimise complacency.
- Fatigue warning
 - "Grave Yard" shifts (Between 00h00 and 06h00) should be monitored very closely. Controllers should make contact with drivers on this shift at regular intervals and these checks must be logged.

- Drivers are required to undergo medicals every six months and these should include:
 - Physical examination
 - Blood and urine test covering:
 - Cannabis and Gamma
 - Blood sugar levels
 - Other latent ailments
 - Audiometric test
 - Advanced ophthalmology test
- All drivers are required to undergo alcohol screening
 - At the commencement of shift
 - Randomly on completion of shift
- Adequate remuneration

6 Data and monitoring

The following data are required to be submitted to the DoT on a monthly basis:

- Combination mass per trip
- Speed profile including ave. speed per month
- Routes travelled (Vehicle tracking system output)
- No. of trips per month
- Tons transported per month
- Ave. payload per month
- Total and average fuel consumption per month
- Total distance travelled per month
- Record of incidents/accidents (RTMS requirement)
- Driver hours (RTMS requirement)
- Driver Performance – reports must be generated from the vehicle management system (See attached example).

7 Administrative rules

The classification of offences and sanctions are given in Annexure A.

ANNEXURE A**CLASSIFICATION OF OFFENCES REGARDING THE OPERATION OF SMART TRUCKS AND THE APPROPRIATE SANCTIONS TO BE IMPOSED FOR SUCH ACTIONS****CLASS A OFFENCE**

Un-Authorized Modification of a Smart Truck

Any change in the parameters of the physical PBS vehicle as specified in the approved design of the PBS vehicle.

RTMS

Suspension of RTMS accreditation

SANCTION

Immediate withdrawal of the Section 81 Permit

CLASS B OFFENCE

Overloading

Overloading of axle groups and combination mass as specified on the Section 81 Permit. A five per cent tolerance on axles and axle units will be permitted subject to the five per cent not exceeding the manufacturers rating for the axle/axle unit. There will be no tolerance permitted on the combination mass for vehicles operating under Section 81 Exemption Permit.

Off-Route Operation of a PBS Vehicle

A Smart Truck may not operate on any other routes other than those specified in the Section 81 Exemption Permit. In the event of a vehicle leaving a prescribed route due to unforeseen circumstances such as an accident the operator must report such to Permit Office in the form of a signed affidavit, witnessed by a commissioner of oaths by no later than 13:00 on the next working day of the Permit Office.

Speed

All Smart Trucks must operate at the speed limits specified on the Section 81 Exemption Permit or at a lower speed where the route is signposted as such.

SANCTION

A written warning will be sent to the operator on the offence. Three such letters in a six month period will result in the withdrawal of the Section 81 Exemption Permit.

CLASS C OFFENCE

Refusal to supply information pertaining to a Smart Truck.

All information pertaining to any Smart Truck requested by the Administration must be supplied by the operator within 10 calendar days of a written or verbal request.

Non Compliance of Section 81 Permit Conditions

The permit conditions as contained in the Section 81 Exemption Permit must be complied with at all times.

SANCTION

A written warning will be sent to the operator regarding the offence. Four letters of this nature in a six-month period will result in the withdrawal of the Section 81 Exemption Permit.

VEHICLE MONITORING BY MEANS OF SATELLITE TRACKING

All operators of Smart Trucks are required to submit to the Permit Office records of satellite tracking for each Smart Truck by no later than the 5th day of the month after the reporting month.

The records must depict the following:

- Period of validity e.g. 01 January 2012 to 31 January 2012
- Smart Truck registration numbers
- Detailed map depicting all trips thereon. The map must be of a suitable size and scale
- Average Payload per Smart Truck
- Actual combination mass of each Smart Truck for all trips
- Average combination mass per Smart Truck
- Any exceptions to the operating requirements as outlined on the Section 81 Exemption Permits in terms of speed, route and combination mass

These records will be pertinent for each Smart Truck and as such each combination will require a report.

APPENDIX C

Trip combination mass significance tests

Analysis of distribution of trip combination mass
Comparing A:RTMS/PBS and B:RTMS/non-PBS

The GLM Procedure

Levene's Test for Homogeneity of GVM Variance ANOVA of Squared Deviations from Group Means					
Source	DF	Sum of Squares	Mean Square	F Value	Pr > F
Vehicle group	1	3.733E15	3.733E15	10.08	0.0015
Error	281926	1.044E20	3.702E14		

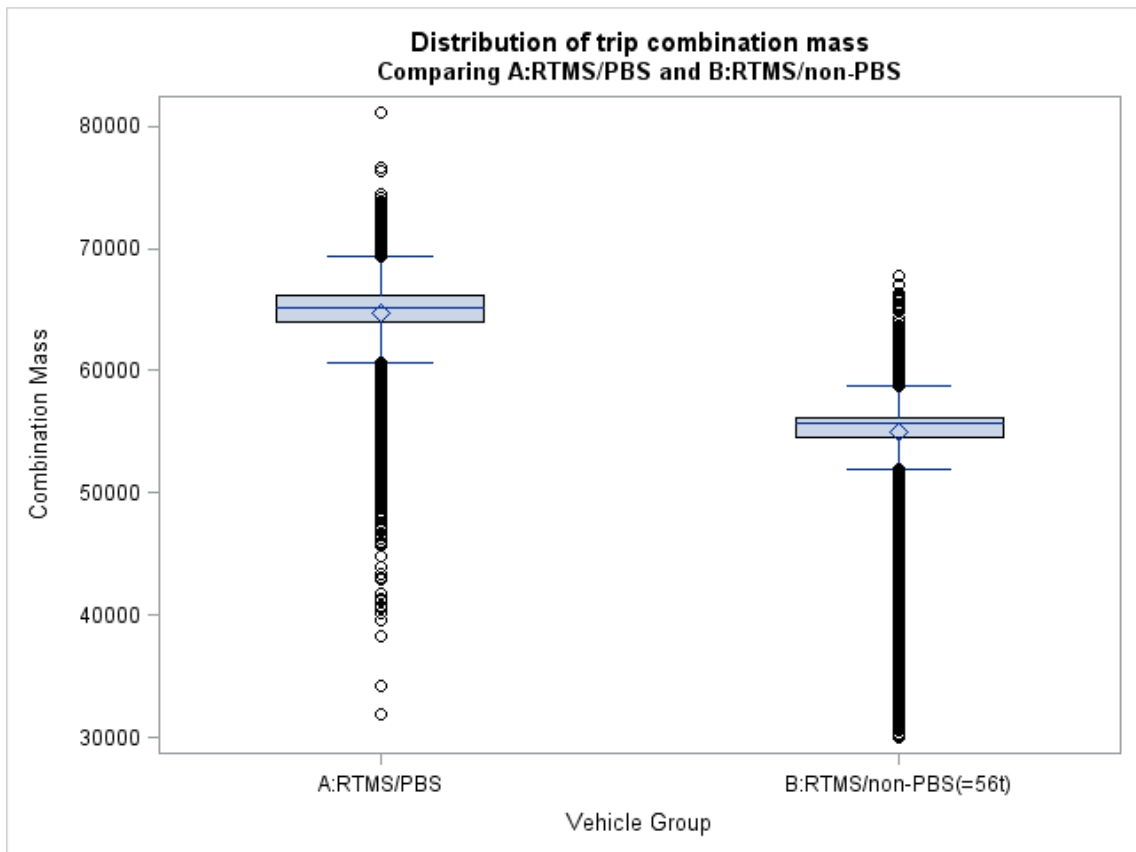

Level of Vehicle group	N	GVM	
		Mean	Std Dev
A:RTMS/PBS	55894	62526.8552	2317.85206
B:RTMS/non-PBS(56 t)	226034	54955.9018	2254.71795

Analysis of distribution of trip combination mass
Comparing A:PBS (64t) and B:RTMS/non-PBS

The GLM Procedure

Levene's Test for Homogeneity of GVM Variance ANOVA of Squared Deviations from Group Means					
Source	DF	Sum of Squares	Mean Square	F Value	Pr > F
Vehicle group	1	2.432E16	2.432E16	65.95	<.0001
Error	227462	8.386E19	3.687E14		

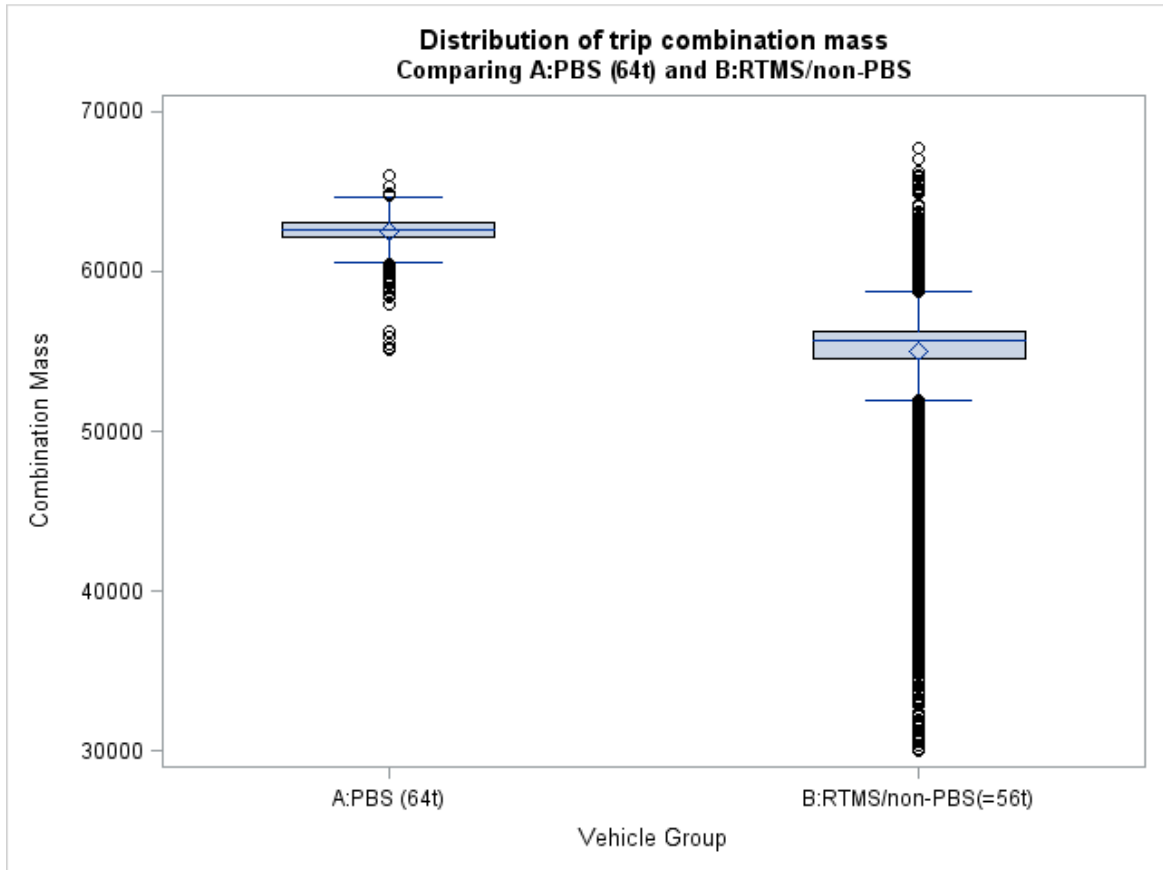

Level of Vehicle group	N	GVM	
		Mean	Std Dev
A:PBS (64 t)	1430	62526.8552	973.53118
B:RTMS/non-PBS(56 t)	226034	54955.9018	2254.71795

Analysis of distribution of trip combination mass
Comparing A:PBS (67t) and B:RTMS/non-PBS

The GLM Procedure

Levene's Test for Homogeneity of GVM Variance ANOVA of Squared Deviations from Group Means					
Source	DF	Sum of Squares	Mean Square	F Value	Pr > F
Vehicle group	1	1.126E17	1.126E17	294.21	<.0001
Error	236002	9.029E19	3.826E14		

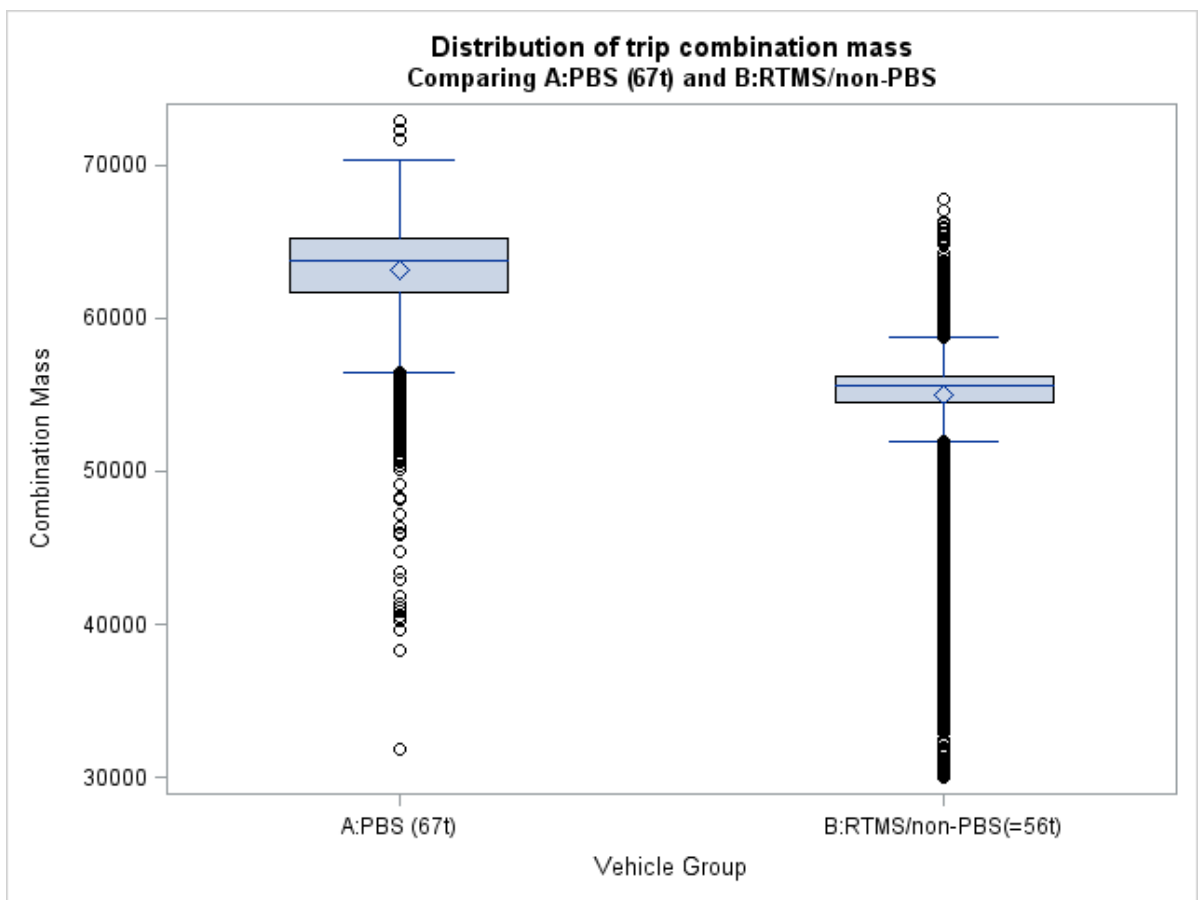

Level of Vehicle group	N	GVM	
		Mean	Std Dev
A:PBS (67 t)	9970	63169.3614	2918.54678
B:RTMS/non-PBS(56 t)	226034	54955.9018	2254.71795

Analysis of distribution of trip combination mass
Comparing A:PBS (67.5t) and B:RTMS/non-PBS

The GLM Procedure

Levene's Test for Homogeneity of GVM Variance ANOVA of Squared Deviations from Group Means					
Source	DF	Sum of Squares	Mean Square	F Value	Pr > F
Vehicle group	1	8.617E16	8.617E16	242.62	<.0001
Error	261383	9.283E19	3.551E14		

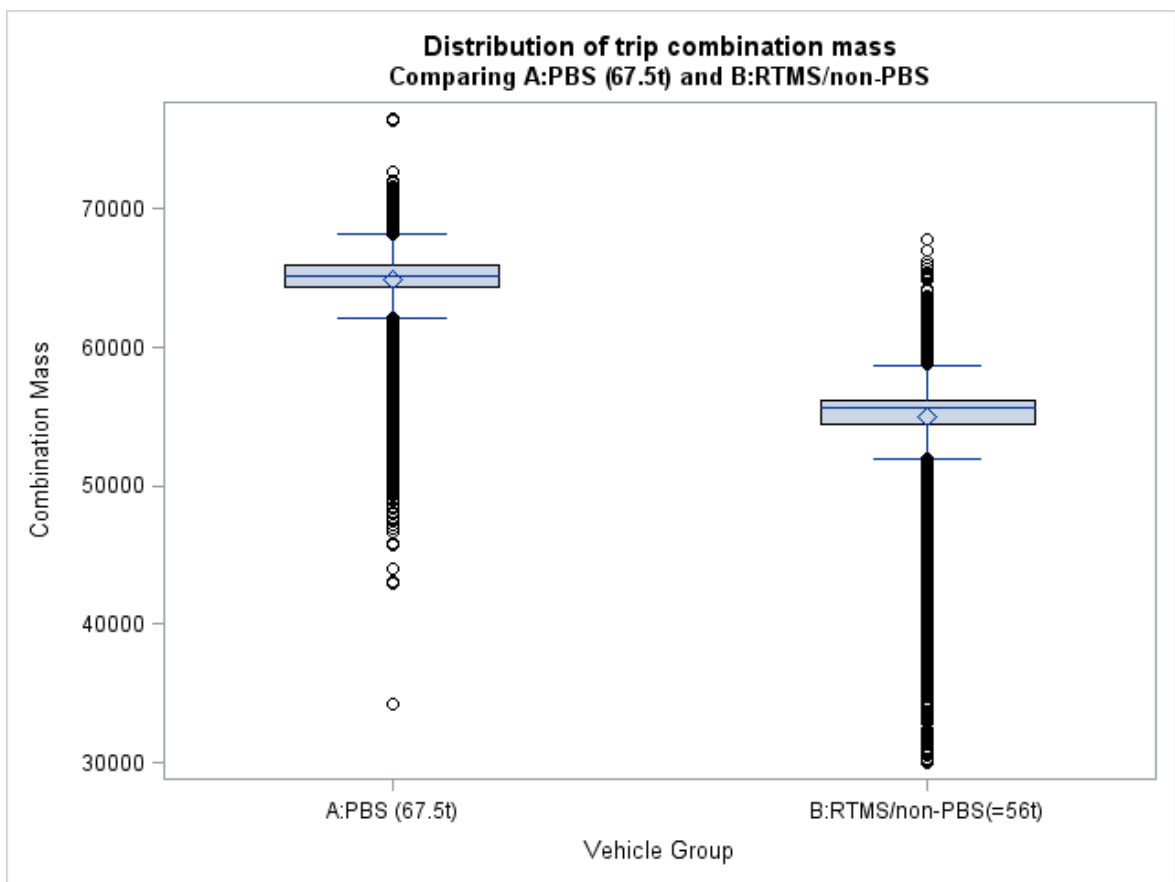

Level of Vehicle group	N	GVM	
		Mean	Std Dev
A:PBS (67.5 t)	35351	64963.1805	1845.24948
B:RTMS/non-PBS(56 t)	226034	54955.9018	2254.71795

Analysis of distribution of trip combination mass
 Comparing A:PBS (70t) and B:RTMS/non-PBS

The GLM Procedure

Levene's Test for Homogeneity of GVM Variance ANOVA of Squared Deviations from Group Means					
Source	DF	Sum of Squares	Mean Square	F Value	Pr > F
Vehicle group	1	2.339E17	2.339E17	621.93	<.0001
Error	235175	8.843E19	3.76E14		

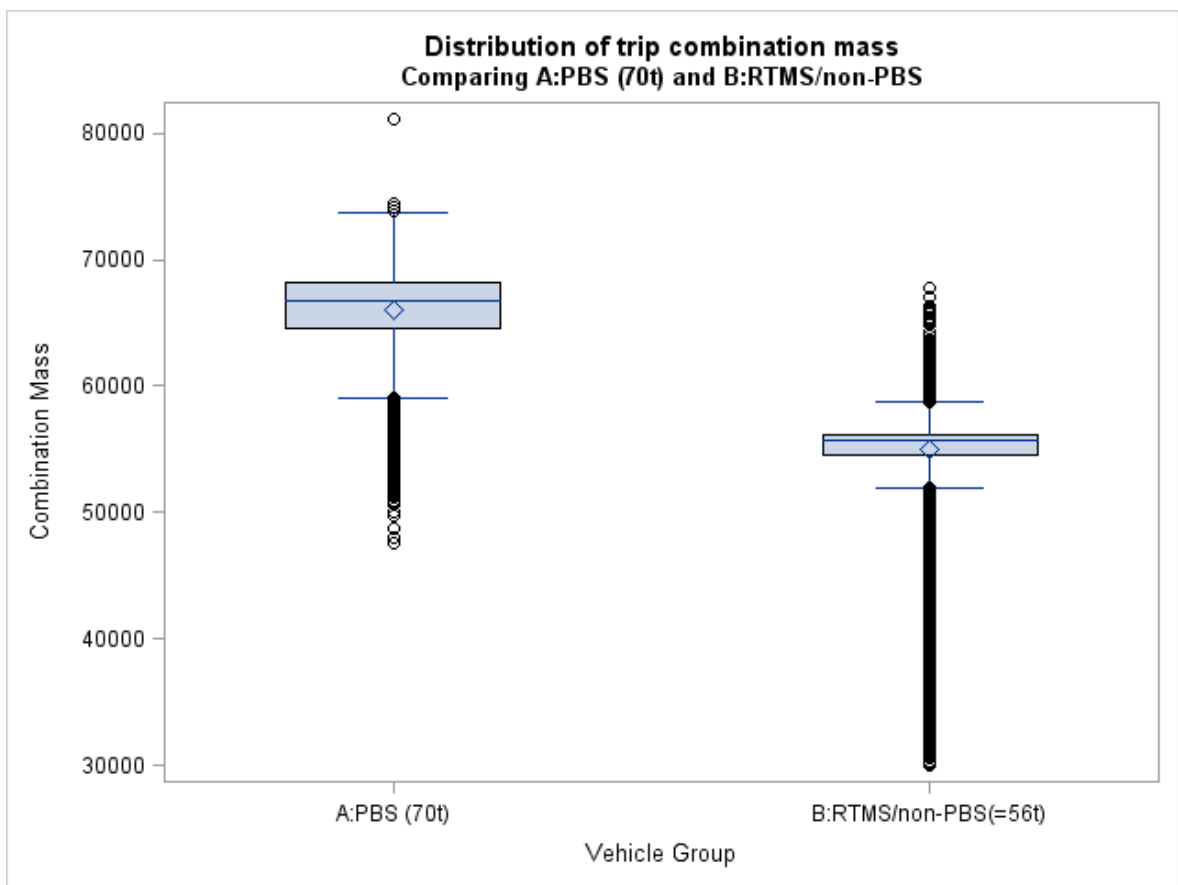

Level of Vehicle group	N	GVM	
		Mean	Std Dev
A:PBS (70 t)	9143	66008.2514	3200.56953
B:RTMS/non-PBS(56 t)	226034	54955.9018	2254.71795

Analysis of distribution of trip combination mass
Comparing A:RTMS/PBS and C+D:Non-RTMS(=56t)

The GLM Procedure

Levene's Test for Homogeneity of GVM Variance ANOVA of Squared Deviations from Group Means					
Source	DF	Sum of Squares	Mean Square	F Value	Pr > F
Vehicle group	1	6.64E18	6.64E18	3663.56	<.0001
Error	180352	3.269E20	1.813E15		

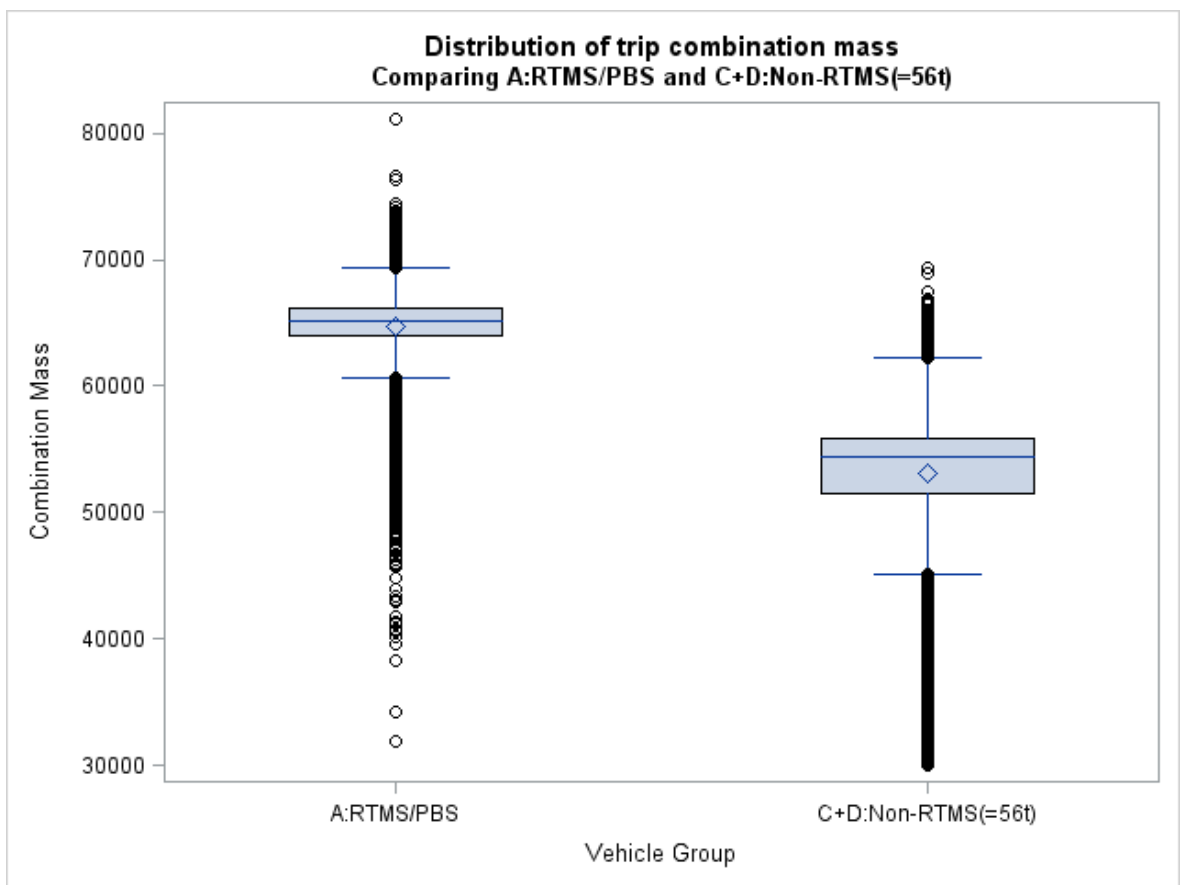

Level of Vehicle group	N	GVM	
		Mean	Std Dev
A:RTMS/PBS	55894	62526.8552	2317.85206
C+D:Non-RTMS(56 t)	124460	53026.2789	4300.39635

Analysis of distribution of trip combination mass
Comparing A:PBS (64t) and C+D:Non-RTMS(=56t)

The GLM Procedure

Levene's Test for Homogeneity of GVM Variance ANOVA of Squared Deviations from Group Means					
Source	DF	Sum of Squares	Mean Square	F Value	Pr > F
Vehicle group	1	4.352E17	4.352E17	178.83	<.0001
Error	125888	3.064E20	2.434E15		

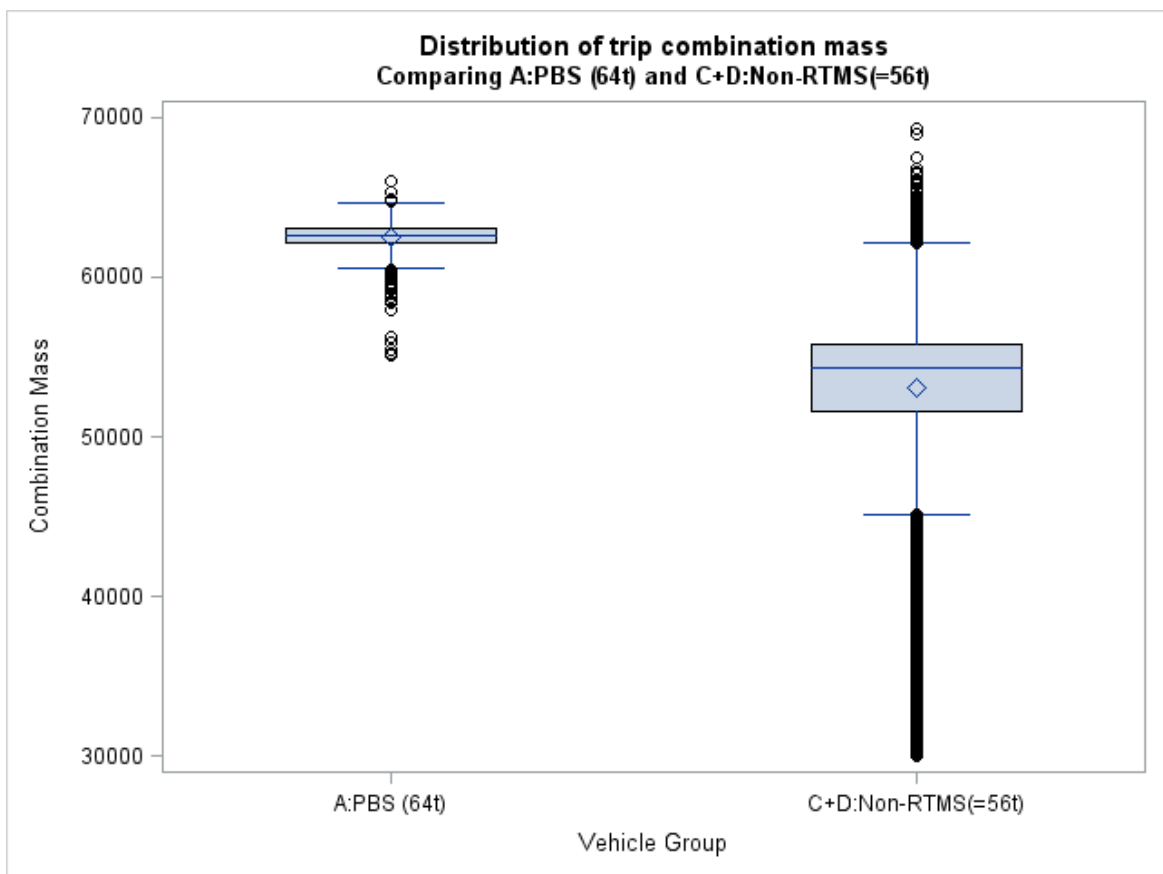

Level of Vehicle group	N	GVM	
		Mean	Std Dev
A:PBS (64 t)	1430	62526.8552	973.53118
C+D:Non-RTMS(56 t)	124460	53026.2789	4300.39635

Analysis of distribution of trip combination mass
Comparing A:PBS (67t) and C+D:Non-RTMS(=56t)

The GLM Procedure

Levene's Test for Homogeneity of GVM Variance ANOVA of Squared Deviations from Group Means					
Source	DF	Sum of Squares	Mean Square	F Value	Pr > F
Vehicle group	1	9.187E17	9.187E17	394.78	<.0001
Error	134428	3.128E20	2.327E15		

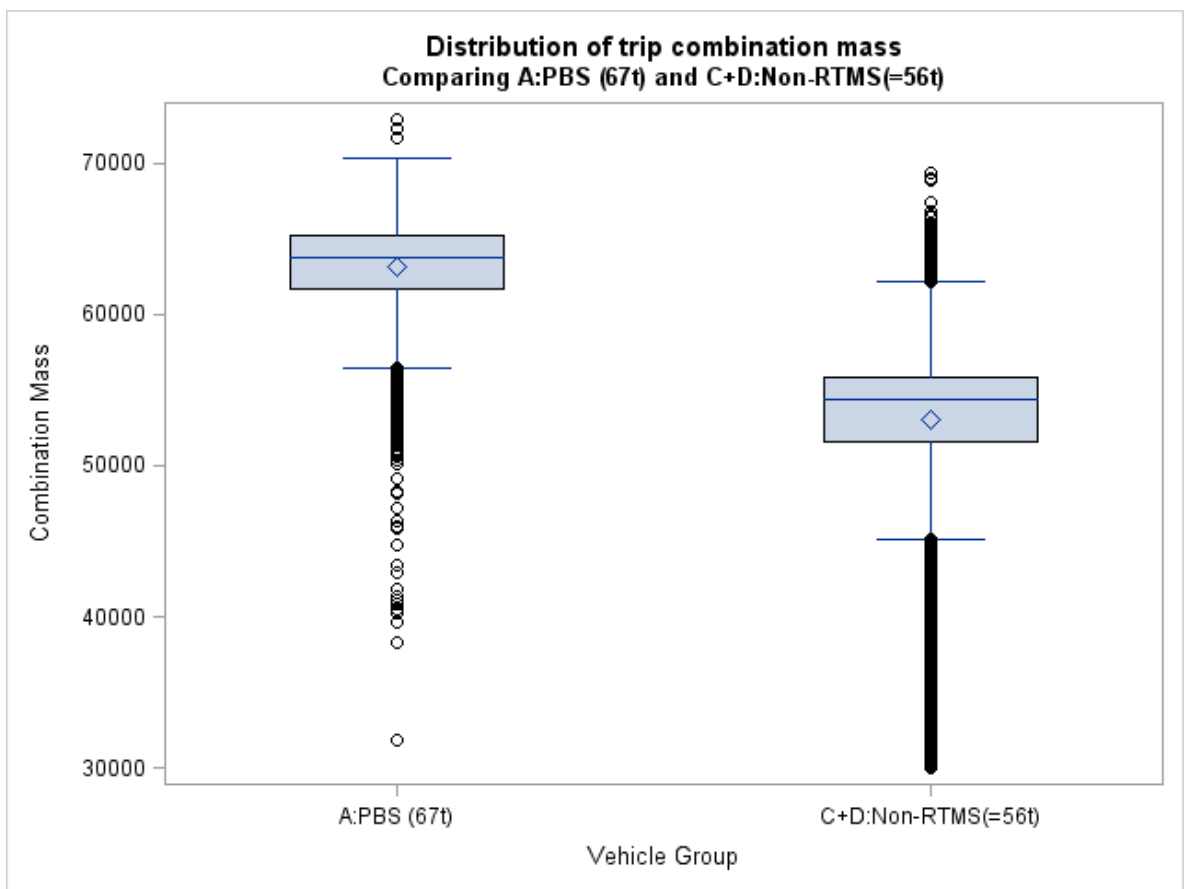

Level of Vehicle group	N	GVM	
		Mean	Std Dev
A:PBS (67 t)	9970	63169.3614	2918.54678
C+D:Non-RTMS(56 t)	124460	53026.2789	4300.39635

Analysis of distribution of trip combination mass
Comparing A:PBS (67.5t) and C+D:Non-RTMS(=56t)

The GLM Procedure

Levene's Test for Homogeneity of GVM Variance ANOVA of Squared Deviations from Group Means					
Source	DF	Sum of Squares	Mean Square	F Value	Pr > F
Vehicle group	1	6.268E18	6.268E18	3176.16	<.0001
Error	159809	3.154E20	1.973E15		

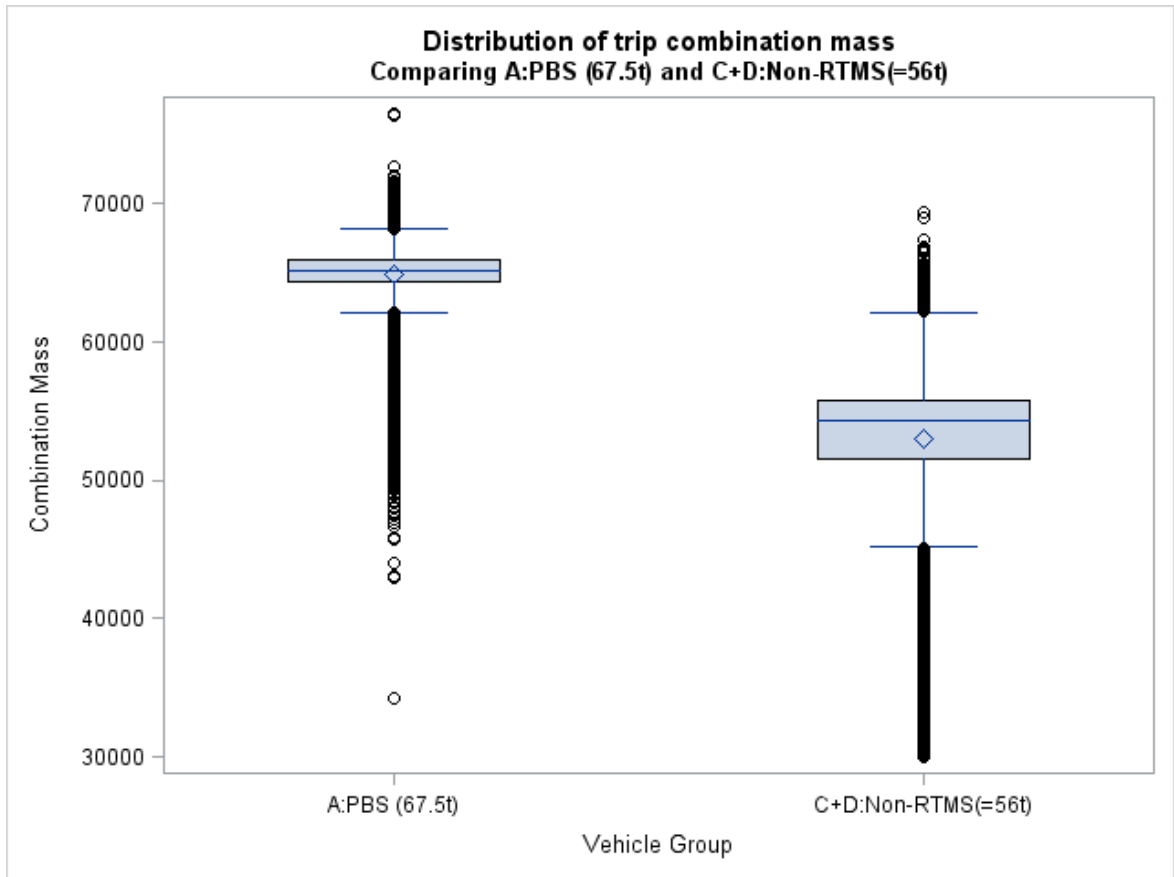

Level of Vehicle group	N	GVM	
		Mean	Std Dev
A:PBS (67.5 t)	35351	64963.1805	1845.24948
C+D:Non-RTMS(56 t)	124460	53026.2789	4300.39635

Analysis of distribution of trip combination mass
Comparing A:PBS (70t) and C+D:Non-RTMS(=56t)

The GLM Procedure

Levene's Test for Homogeneity of GVM Variance ANOVA of Squared Deviations from Group Means					
Source	DF	Sum of Squares	Mean Square	F Value	Pr > F
Vehicle group	1	5.798E17	5.798E17	249.11	<.0001
Error	133601	3.11E20	2.328E15		

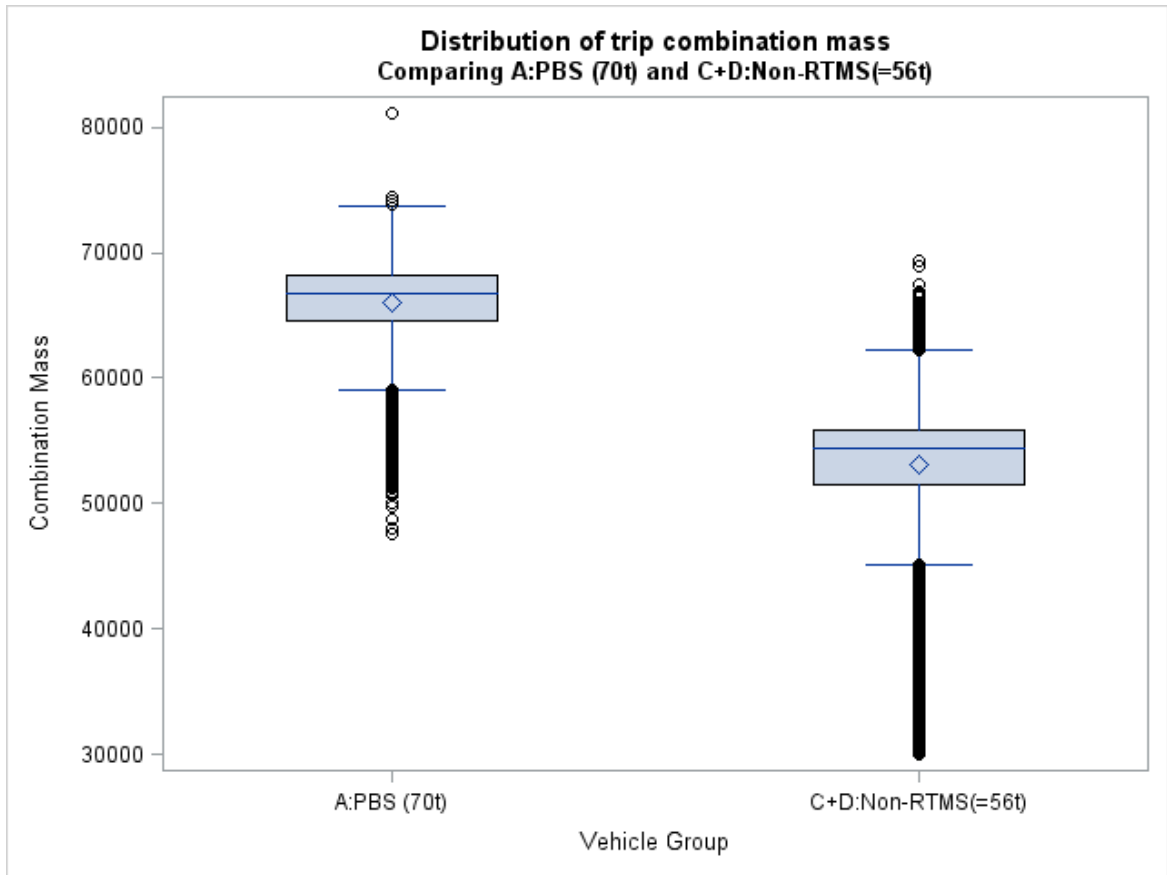

Level of Vehicle group	N	GVM	
		Mean	Std Dev
A:PBS (70 t)	9143	66008.2514	3200.56953
C+D:Non-RTMS(56 t)	124460	53026.2789	4300.39635

Analysis of distribution of trip combination mass
Comparing B:RTMS/non-PBS and C+D:Non-RTMS(=56t)

The GLM Procedure

Levene's Test for Homogeneity of GVM Variance ANOVA of Squared Deviations from Group Means					
Source	DF	Sum of Squares	Mean Square	F Value	Pr > F
Vehicle group	1	1.443E19	1.443E19	12963.5	<.0001
Error	350492	3.902E20	1.113E15		

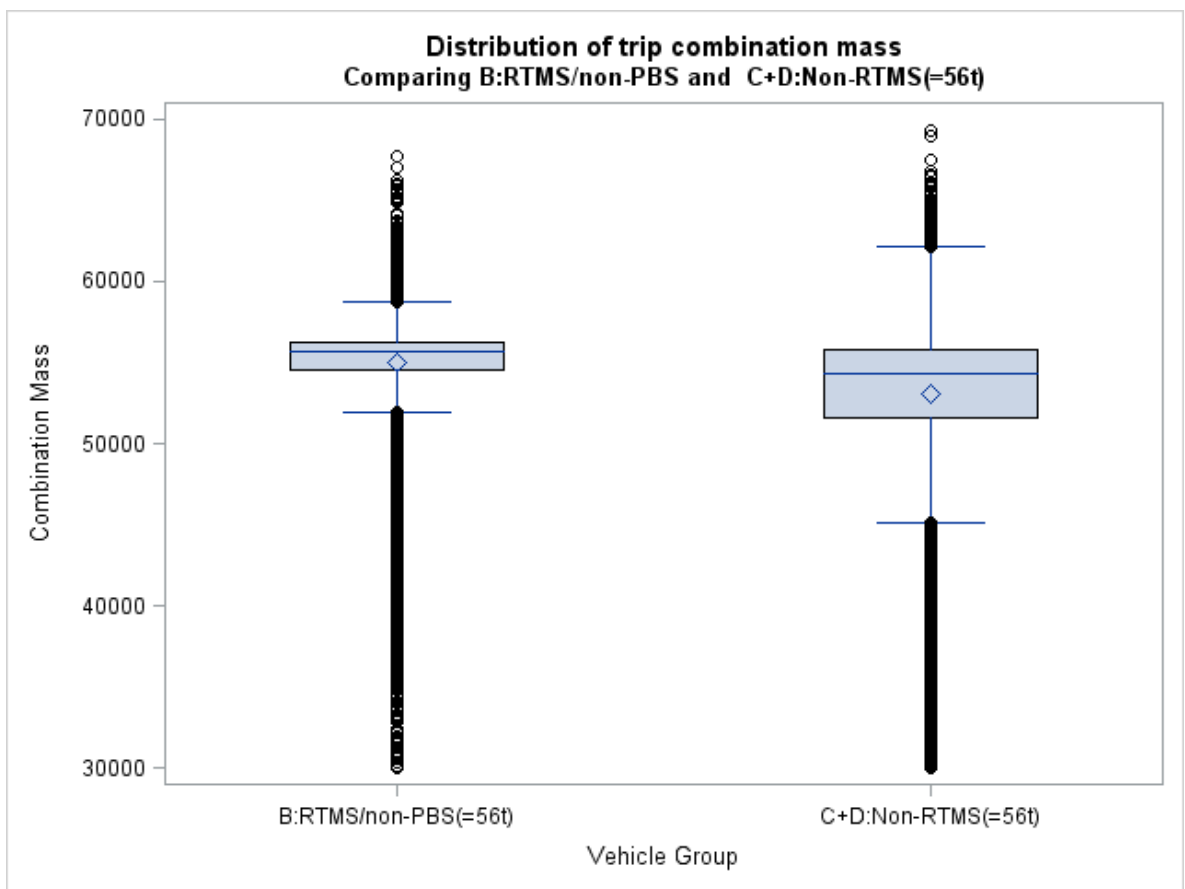

Level of Vehicle group	N	GVM	
		Mean	Std Dev
B:RTMS/non-PBS(56 t)	226034	54955.9018	2254.71795
C+D:Non-RTMS(56 t)	124460	53026.2789	4300.39635

APPENDIX D1

Trip metadata

Table D1-1 PBS and non-PBS trips per calendar year during the sample period

Vehicle Category	June to Dec 2011	2012	Jan to Sept 2013	Total
A. RTMS/PBS	10 410	25 904	19 653	55 967
B. to G. Non-PBS	128 343	189 024	117 956	432 323
% PBS trips	8.1	13.7	16.7	12.9

Table D1-2 PBS and non-PBS tonnages transported per calendar year during the sample period

Vehicle Category	June to Dec 2011	2012	Jan to Sept 2013	Total
A. RTMS/PBS	485 356	1 187 241	933 568	2 606 165
B. to G. Non-PBS (combination mass)	6 508 160	9 575 992	6 074 698	22 158 850
B. to G. Non-PBS (payload)	4 425 549	6 511 675	4 130 795	15 068 018
% PBS trips	11.0	18.2	22.6	17.3

PBS tonnages were obtained from the PBS vehicle trip data received from the PBS operators. Tonnage transported by non-PBS vehicles was estimated by adjusting the combination mass data by a Payload Efficiency Factor of 0.68 to convert to tons of timber.

Table D1-3 PBS demonstration vehicle trips from 2008 to 2013

	2008	2009	2010	2011	2012	2013	Total
Timber 24	676	650	579	567	624	453	3549
Super Group	645	635	669	720	704	492	3 865
Timber Logistics Services		896	10135	9791	10159	7716	38 697
Timbernology			376	4017	3582	2689	10 664
Unitrans Timber				758	3428	2621	6 807
Gaskells				468	2986	1882	5 336
Buhle Betfu					4785	4531	9 316
Zabalaza Hauliers						311	311
Total (to end Sept 2013)						20 695	
Total (to end Dec 2013)	1 321	2 181	11 759	16 321	26 268	27 593 ¹	85 443
Accumulated trips	1 321	3 502	15261	31 582	57 850	85 443	

Note: ¹ Projection based on January to September 2013 data

Table D1-4 PBS demonstration vehicle kms travelled from 2008 to 2013

	2008	2009	2010	2011	2012	2013 (Jan - Sept)
Timber 24	296 500	205 596	237 723	262 047	224 501	192 990
Super Group	240 000	266 994	273 698	269 708	250 005	135 738
Timber Logistics Services		349 000	3 926 632	3 020 468	2 771 319	2 251 142
Timbernology			127 823	1 532 149	1 303 932	1 035 674
Unitrans Timber				343 647	1 497 013	1 111 654
Gaskells				207 730	877 690	687 472
Buhle Betfu					1 136 612	1 025 202
Zabalaza Hauliers						102 531
Total (to end Sept 2013)						6 542 403
Total (to end Dec 2013)	536 500	821 590	4 565 876	5 635 749	8 061 072	8 723 204 ¹
Accumulated kms travelled	536 500	1 358 090	5 923 966	11 559 715	19 620 787	28 343 991

Note: ¹ Projection based on January to September 2013 data

APPENDIX D2

Trip combination mass metadata

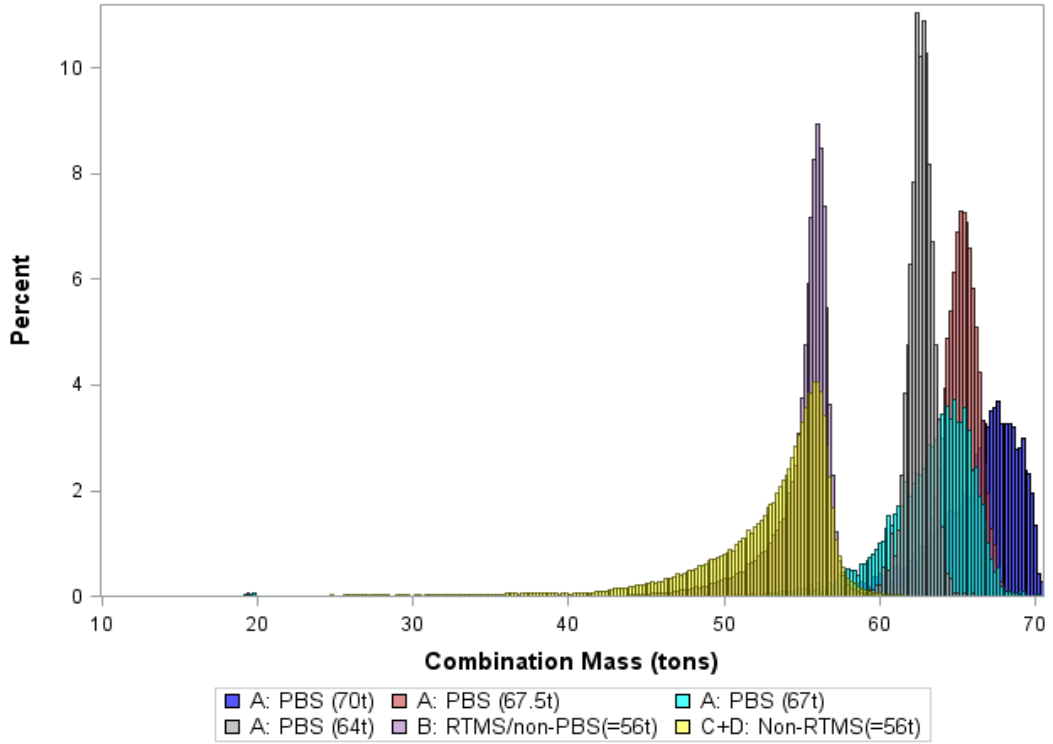

Figure D2-1 Trip combination mass distribution of RTMS/PBS (Category A), RTMS/non-PBS (Category B) and Non-RTMS=56t (Categories C & D) vehicles

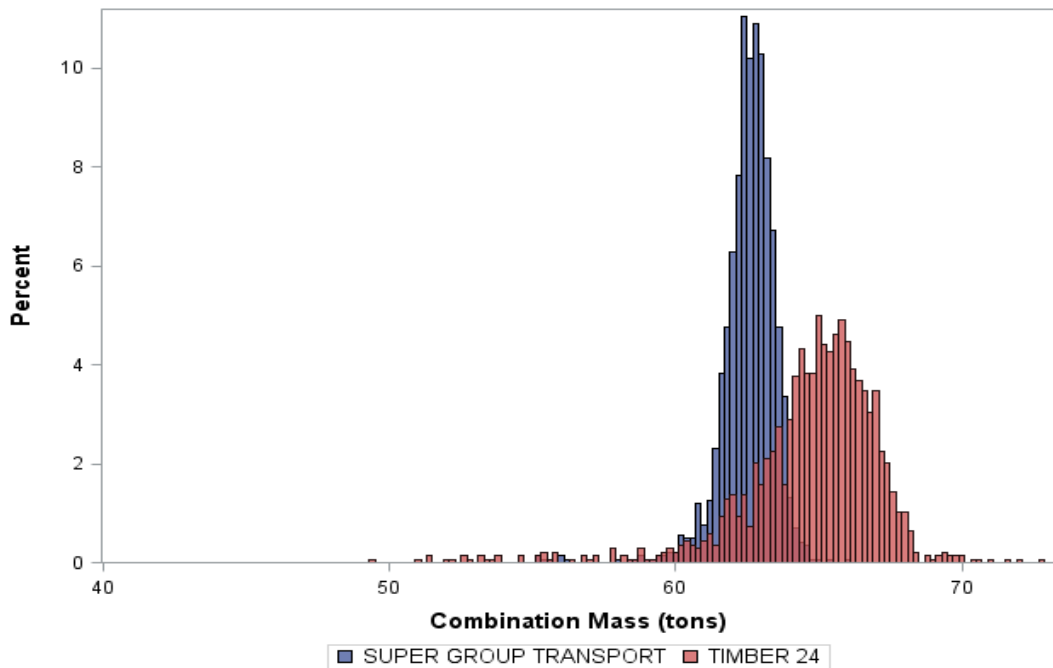

Figure D2.2 Trip combination mass distribution for Super Group Transport (PMCM=64 t) and Timber 24 (PMCM=67.5 t)

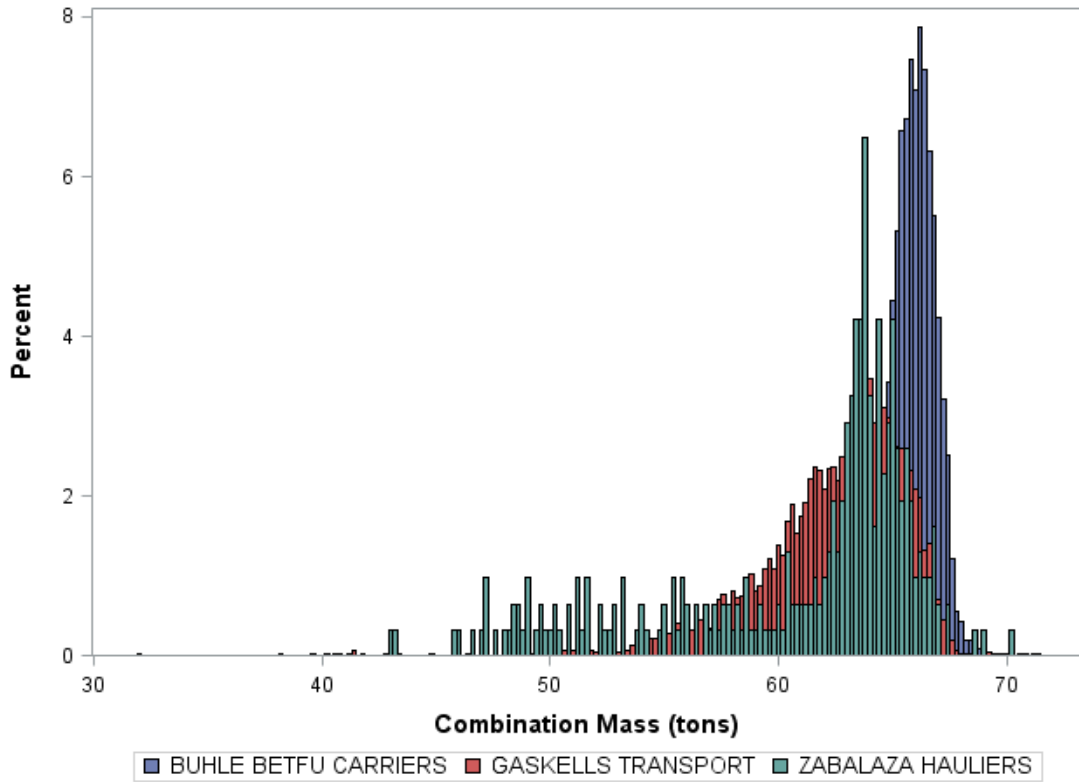

Figure D2.3 Trip combination mass distribution for Buhle Betfu Carriers (PMCM=67.5 t), Gaskells Transport (PMCM=67 t) and Zabalaza Hauliers (PMCM=67.5 t)

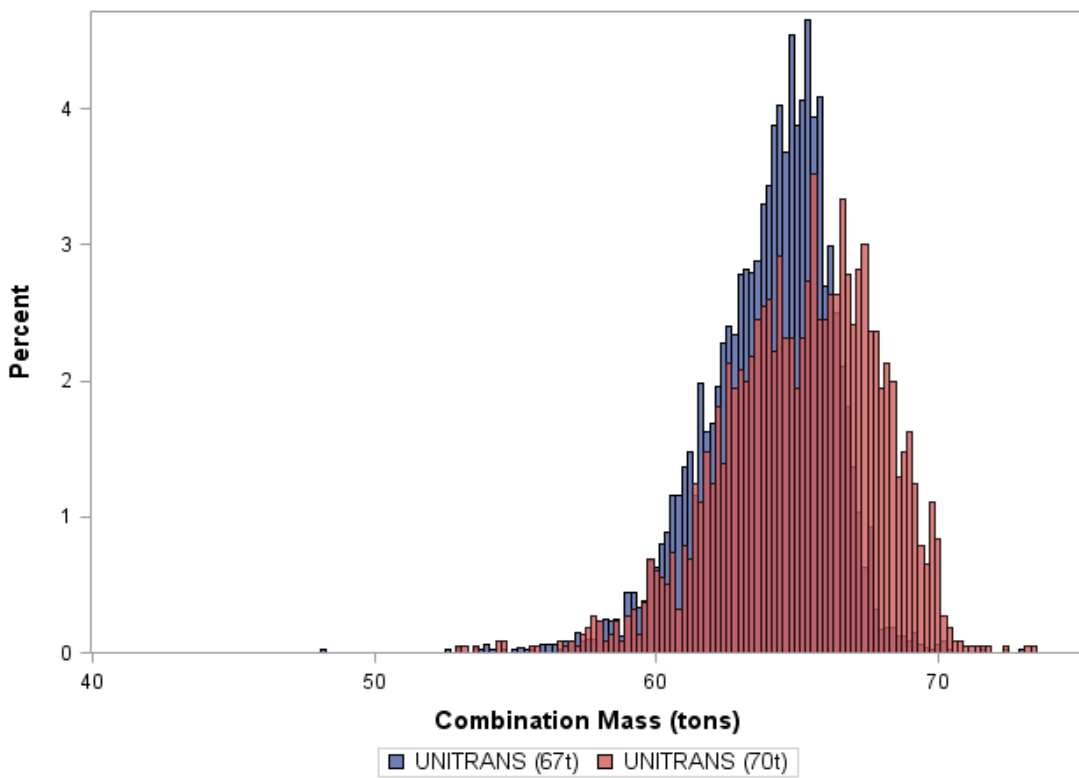

Figure D2.4 Trip combination mass distribution for Unitrans (PMCM=67 t and 70 t)

A summary of the F and p values from these tests is provided in Table D2-1, together with the standard deviations of each vehicle category. The means and number of observations per category are listed in Table 5-4. The results in green indicate that the vehicle category in the row has a significantly lower variance (or standard deviation) of combination mass than the corresponding vehicle category in the column, while the opposite result is indicated by the values in red. Non-coloured results indicate that there is no significant difference in combination mass variance between the two vehicle categories.

Table D2-1 Summary of significance tests for categories A to D and data sample > 30 t for the sample period

Vehicle category	Std dev (kg)	B: RTMS/non-PBS	C+D: non-RTMS
		2 255	4 300
A: PBS (All)	2 318	F=10.1 p=0.0015	F=3663.6 p<0.0001
A: PBS (64t)	974	F=65.95 p<0.0001	F=178.8 p<0.0001
A: PBS (67t)	2 919	F=294.2 p<0.0001	F=394.8 p<0.0001
A: PBS (67.5t)	1 845	F=242.6 p<0.0001	F=3176.2 p<0.0001
A: PBS (70t)	3 201	F=621.9 p<0.0001	F=249.1 p<0.0001
B: RTMS/non-PBS	2 255	n/a	F=12963.5 p<0.0001

Table D2-2 Summary statistics for all PBS and non-PBS vehicles, Categories A to F for the sample period

Analysis Variable: Combination mass (kg)					
Vehicle category	N	Mean	Std Dev	Minimum	Maximum
A. RTMS/PBS (Shifted CM) ¹	55 967	62 497	2 829	11 548	77 664
B. RTMS/Non-PBS	226 256	54 922	2 505	13 600	67 750
C. Non-RTMS/>50vtpm	82 290	52 632	5 392	3 800	68 960
D. Non-RTMS/<50vtpm	43 371	53 017	4 324	12 750	69 360
E. RTMS/non-PBS (<56t)	4 664	46 869	3 990	15 340	57 660
F. Non-RTMS (<56t)	40 843	30 687	14 973	5 800	64 340
PBS vehicles per PMCM					
PBS (64.0t)	1 431	62 497	1 500	19 340	66 000
PBS (67.0t)	9 988	63 091	3 452	19 200	72 920
PBS (67.5t)	35 394	64 908	2 426	13 960	76 540
PBS (70.0t)	9 154	65 952	3 584	17 750	81 120

Note: ¹ Combination masses of the 67, 67.7 and 70 ton PBS vehicles aligned to the mean of the 64 ton PBS vehicle for the statistical analysis of the Category A (PBS) dataset

Table D2-3 Summary of significance tests for Category A, per PBS operator and PMCM category

Vehicle category	Std dev (kg)	B: RTMS/non-PBS	C+D: non-RTMS
		2 255	4 300
A: PBS (All)	2 318	F=10.1 p<0.0015	F=3663.6 p<0.0001
A: PBS (Super Group, 64t)	974	F=66.0 p<0.0001	F=178.8 p<0.0001
A: PBS (Gaskells, 67t)	3 253	F=401.4 p<0.0001	F=130.7 p<0.0001
A: PBS (Unitrans, 67t)	2 237	F=0.08 P=0.7747	F=350.5 p<0.0001
A: PBS (Buhle Betfu, 67.5t)	1 844	F=69.6 p<0.0001	F=861.9 p<0.0001
A: PBS (Timber 24, 67.5t)	2 528	F=6.29 P=0.0122	F=82.2 p<0.0001
A: PBS (Timber Logistics Services, 67.5t)	1 592	F=410.8 p<0.0001	F=2487.1 p<0.0001
A: PBS (Zabalaza Hauliers, 67.5t)	5 622	F=574.5 P<0.0001	F=21.14 P<0.0001
A: PBS (Timberology, 70t)	3 274	F=566.9 p<0.0001	F=169.1 p<0.0001
A: PBS (Unitrans, 70t)	2 776	F=39.81 p<0.0001	F=102.0 p<0.0001
B: RTMS/non-PBS	2 255	n/a	F=12963.5 p<0.0001

Table D2-4 Summary statistics of Timberology PBS per timber species, January 2011 to September 2013

Species	N	Mean	Std Dev	Minimum	Maximum
Gum	3 600	66.124	2.894	47.950	73.640
Pine	2 422	67.732	2.165	28.650	71.500
Wattle	531	65.101	3.490	30.740	72.150
Total	6 553	66.636	2.846	28.650	73.640

Table D2-5 shows the comparison of overloading and under-loading patterns of the PBS and various categories of non-PBS vehicles. As indicated in Chapter 4, because of the conservative assumption of a PMCM of 56 t for all Uncoded vehicles, it is likely that their overloading characteristics are under-represented (0.22% >10% overloaded) and their under-loading characteristics are over-represented (48.7% >10% under-loaded).

Table D2-5 Extent of overloading and under-loading of vehicle categories A to G for the sample period

Vehicle category	No of trips	% of sample	Level of under-loading (%)			Level of overloading (%)			
			Trips >10% under-loaded	Trips >5% under-loaded	Trips >2% under-loaded	Trips >0% over-loaded	Trips >2% over-loaded	Trips >5% over-loaded	Trips >10% over-loaded
A. RTMS/PBS	55 967	11.4	6.77	27.91	80.39	1.63	0.26	0.04	0.01
B. RTMS/non-PBS (=56t)	226 256	46.1	4.96	14.25	30.32	33.59	3.04	0.28	0.03
C. Non-RTMS (=56t, >50 vtpm)	82 290	16.7	19.94	36.28	56.98	19.55	3.15	0.36	0.04
D. Non-RTMS (=56t, <50 vtpm)	43 371	8.8	19.71	40.73	60.23	21.75	7.51	2.10	0.34
E. RTMS/non-PBS (<56t)	4 664	0.9	11.99	42.37	67.67	19.60	11.28	6.86	3.58
F. Non-RTMS (<56t)	40 843	8.3	33.68	49.90	63.33	27.11	19.45	11.97	4.60
G. Uncoded	37 899	7.7	48.67	60.12	72.14	13.70	4.04	1.12	0.22
Total	491 290	100.0							

Table D2-6 Extent of “aligned” levels of overloading and under-loading of vehicle categories A to F for the sample period

Vehicle category	No of trips	% of sample	Level of under-loading (%)		Level of overloading (%)		
			Trips >10% under-loaded	Trips >5% under-loaded	Trips >0% over-loaded	Trips >2% over-loaded	Trips >5% over-loaded
A. RTMS/PBS	55 967	12.3	6.77	27.91	1.63	0.26	0.04
	No of trips	% of sample	Trips > 8% under-loaded	Trips > 3% under-loaded	Trips > 2% over-loaded	Trips > 4% over-loaded	Trips > 7% over-loaded
B. RTMS/non-PBS (=56t)	226 256	49.9	7.50	23.09	3.04	0.60	0.10
C. Non-RTMS (=56t,>50vtpm)	82 290	18.1	25.12	48.55	3.15	0.73	0.14
D. Non-RTMS (=56t,<50vtpm)	43 371	9.6	26.53	53.18	7.51	3.11	0.94
E. RTMS/non-PBS (<56t)	4 664	1.0	19.98	59.37	11.28	7.65	5.45
F. Non-RTMS (<56t)	40 843	9.0	39.21	58.84	19.45	14.11	8.38
Total (excluding Category G)	453 391	100.0					

Table D2-7 Trip savings of 31 PBS demonstration vehicles compared with 56 t legal baseline vehicles, January to December 2011

Vehicle description	Number of vehicles	Total tons moved (per vehicle)	Average Combination mass	Average Payload (tons)	Average trips saved per vehicle per month	Total trips saved per month
SuperGroup baseline	1	2 299	56.1	38.3		
SuperGroup PBS (1 vehicle)	1	2 603	62.7	43.4	8.0	8.0
Timber 24 Baseline	1	1 761	55.3	38.0		
Timber 24 PBS (1 vehicle)	1	2 173	65.2	46.0	9.9	9.9
TLS Baseline	5	2 224	55.2	37.9		
TLS PBS (15 vehicles)	15	2 473	65.3	45.4	10.8	161.7
Timberology baseline	10	3 449	56.0	37.8		
Timberology PBS (7 vehicles)	7	2 182	63.2	44.5	8.7	60.8
Unitrans baseline	6	1 221	52.5	33.5		
Unitrans PBS (2, 7 vehicles)	7	1 866	64.5	44.9	14.1	99.0

Table D2-8 Trip savings of 46 PBS demonstration vehicles compared with 56 t legal baseline vehicles, January to December 2012

Vehicle description	Number of vehicles	Ave tons moved (per vehicle/month)	Average Combination mass (tons)	Average Payload (tons)	Average trips saved per vehicle/month	Total trips saved per month
Super Group baseline	1	2 212	56.1	38.3		
Super Group PBS (64t)	1	2 535	62.6	43.1	7.4	7.4
Timber 24 Baseline	1	1 830	55.2	37.9		
Timber 24 PBS (67.5t)	1	2 265	64.0	44.8	9.2	9.2
TLS Baseline	5	2 276	55.5	37.8		
TLS PBS (67.5t)	15	2 550	64.7	45.2	11.0	165.7
Timberology baseline	10	1 825	55.0	37.5		
Timberology PBS (70t)	7	2 073	66.0	46.4	10.6	74.2
Unitrans timber baseline	6	561	50.0	32.0		
Unitrans PBS (2x67t & 5x70t)	7	1 839	64.1	44.5	16.1	113.0
Gaskells baseline	5	1 437	54.1	36.4		
Gaskells PBS (67t)	5	2 145	62.7	42.8	8.8	44.1
Buhle Betfu baseline	5	2 904	55.5	37.9		
Buhle Betfu PBS (67.5t)	10	2 761	65.8	46.1	13.0	129.6

Table D2-9 Trip savings of 48 PBS demonstration vehicles compared with 56 t legal baseline vehicles, January to September 2013

Vehicle description	Number of vehicles	Total tons moved (per vehicle)	Average Combination mass	Average Payload (tons)	Average trips saved per vehicle per month	Total trips saved per month
SuperGroup baseline	1	2 081	55.7	38.1		
SuperGroup PBS (1 vehicle)	1	1 937	62.0	42.8	5.6	5.6
Timber 24 Baseline	1	1 937	53.8	36.3		
Timber 24 PBS (1 vehicle)	1	2 284	64.7	45.5	12.7	12.7
TLS Baseline	5	2 522	54.5	38.2		
TLS PBS (15 vehicles)	15	2 691	64.7	45.5	11.3	170.1
Timberology baseline	10	2 531	54.6	37.6		
Timberology PBS (7 vehicles)	7	1 942	65.1	45.1	8.6	60.1
Unitrans timber baseline	6	311	51.8	33.5		
Unitrans PBS (7 vehicles)	7	1 832	63.7	44.0	13.1	91.4
Gaskells baseline	5	1 691	54.4	36.7		
Gaskells PBS (5 vehicles)	5	1 757	61.6	41.9	5.9	29.7
Buhle Betfu baseline	5	2 868	55.5	38.0		
Buhle Betfu PBS (10 vehicles)	10	2 280	65.0	45.7	10.1	101.1
Zabalaza baseline	4	1 798	54.8	37.6		
Zabalaza PBS (2 vehicles)	2	2 167	60.9	42	6.0	12.1

APPENDIX D3

Fuel efficiency metadata

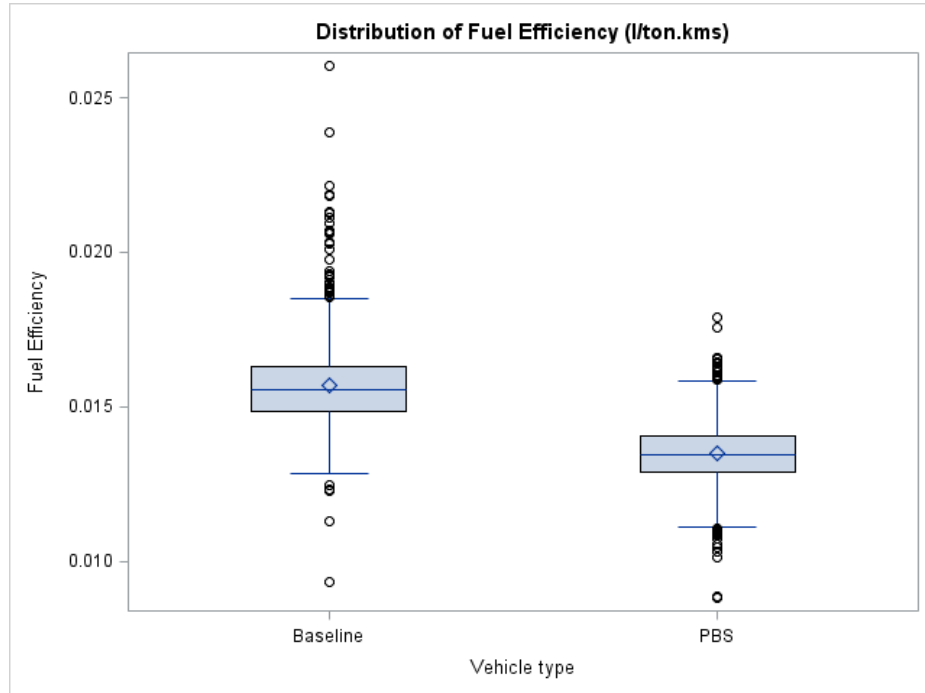

Figure D3-1 Distribution of fuel efficiency for baseline and PBS vehicles

Based on the histograms of fuel efficiency in Figure 5-10 and the large sample sizes, as shown in Tables D3-1 to D3-3, one can assume, using the Central Limit Theorem, that the means of the two vehicles categories are normally distributed. Therefore the use of the group t-test was considered appropriate for testing the difference in means between the fuel efficiencies of the two vehicle categories. Using all the available data, as described previously, the group t-test was performed on the fuel efficiency variable. Table D3-4 provides some descriptive statistics of fuel efficiency for PBS and baseline vehicles and Table D3-5 gives a summary of the test statistics from the t-tests performed.

Table D3-1 Fuel efficiencies of PBS and baseline vehicles of the forestry PBS transport operators, January to December 2011

	Number of vehicles	Average Kms travelled	Total tons moved (per vehicle)	Average Payload (tons)	Fuel consumption (l/100km)	Fuel Efficiency (l/ton.km)	Average %age fuel savings
SuperGroup baseline	1	18 743	2 081	38.1	62.5	0.0164	
SuperGroup PBS (64t)	1	19 391	1 937	42.8	60.8	0.0142	13.4
Timber 24 Baseline	1	20 017	1 937	36.3	59.2	0.0163	
Timber 24 PBS (67.5t)	1	21 443	2 284	45.5	59.9	0.0132	19.3
TLS Baseline	5	15 668	2 522	38.2	53.5	0.0140	
TLS PBS (67.5t)	15	16 432	2 691	45.5	58.7	0.0129	7.9
Timberology baseline	10	12 972	2 531	37.6	56.5	0.0150	
Timberology PBS (70t)	7	16 704	1 942	45.1	64.1	0.0142	5.4
Unitrans timber baseline	6	3 755	311	33.5	60.1	0.0179	
Unitrans PBS (2x67t & 5x70t)	7	17 645	1 832	44.0	62.1	0.0141	21.3
Gaskells baseline	5	12 878	1 691	36.7	60.3	0.0164	
Gaskells PBS (67t)	5	15 277	1 757	41.9	62.9	0.0150	8.6
Buhle Betfu baseline	5	12 461	2 868	38.0	61.3	0.0161	
Buhle Betfu PBS (67.5t)	10	11 391	2 280	45.7	59.2	0.0130	19.7
Zabalaza baseline	4	13 330	1 798	37.6	58.8	0.0156	
Zabalaza PBS (2 vehicles)	2	17 089	2 167	42	58.5	0.0139	10.9

Table D3-2 Fuel efficiencies of PBS and baseline vehicles of the forestry PBS transport operators, January to December 2012

	Number of vehicles	Average Kms travelled	Total tons moved (per vehicle)	Average Payload (tons)	Fuel consumption (l/100km)	Fuel Efficiency (l/ton.km)	Average %age fuel savings
SuperGroup baseline	1	20 834	2 212	38.3	59.9	0.0156	
SuperGroup PBS (64t)	1	20 834	2 535	43.1	61.1	0.0142	9.4
Timber 24 baseline	1	17 708	1 830	37.9	59.1	0.0156	
Timber 24 PBS (67.5t)	1	18 814	2 265	44.8	61.7	0.0138	11.7
TLS baseline	5	15 245	2 276	37.8	59.2	0.0157	
TLS PBS (67.5t)	15	15 396	2 550	45.2	59.8	0.0132	15.5
Timberology baseline	10	12 409	1 825	37.5	57.4	0.0153	
Timberology PBS (70t)	7	16 709	2 073	46.4	60.2	0.0130	15.2
Unitrans timber baseline	6	7 010	561	32.0	61.2	0.0191	
Unitrans PBS (2x67t & 5x70t)	7	17 846	1 839	44.5	59.9	0.0135	29.6
Gaskells baseline	5	10 651	1 437	36.4	60.0	0.0165	
Gaskells PBS (67t)	5	14 589	2 145	42.8	62.3	0.0146	11.7
Buhle Betfu baseline	5	13 509	2 904	37.9	58.2	0.0154	
Buhle Betfu PBS (67.5t)	10	14 208	2 761	46.1	54.7	0.0119	22.7

Table D3-3 Fuel efficiencies of PBS and baseline vehicles of the forestry PBS transport operators, January to September 2013

	Number of vehicles	Average Kms travelled	Total tons moved (per vehicle)	Average Payload (tons)	Fuel consumption (l/100km)	Fuel Efficiency (l/ton.km)	Average %age fuel savings
SuperGroup baseline	1	18 743	2 081	38.1	62.5	0.0164	
SuperGroup PBS (64t)	1	19 391	1 937	42.8	60.8	0.0142	13.4
Timber 24 Baseline	1	20 017	1 937	36.3	59.2	0.0163	
Timber 24 PBS (67.5t)	1	21 443	2 284	45.5	59.9	0.0132	19.3
TLS Baseline	5	15 668	2 522	38.2	53.5	0.0140	
TLS PBS (67.5t)	15	16 432	2 691	45.5	58.7	0.0129	7.9
Timberology baseline	10	12 972	2 531	37.6	56.5	0.0150	
Timberology PBS (70t)	7	16 704	1 942	45.1	64.1	0.0142	5.4
Unitrans timber baseline	6	3 755	311	33.5	60.1	0.0179	
Unitrans PBS (2x67t & 5x70t)	7	17 645	1 832	44.0	62.1	0.0141	21.3
Gaskells baseline	5	12 878	1 691	36.7	60.3	0.0164	
Gaskells PBS (67t)	5	15 277	1 757	41.9	62.9	0.0150	8.6
Buhle Betfu baseline	5	12 461	2 868	38.0	61.3	0.0161	
Buhle Betfu PBS (67.5t)	10	11 391	2 280	45.7	59.2	0.0130	19.7
Zabalaza baseline	4	13 330	1 798	37.6	58.8	0.0156	
Zabalaza PBS (2 vehicles)	2	17 089	2 167	42.0	58.5	0.0139	10.9

Table D3-4 Descriptive statistics of fuel efficiency for the two vehicle categories and the difference between the categories

Analysis Variable: Fuel efficiency					
Vehicle Category	N	Mean	Std. Dev.	Minimum	Maximum
Baseline	753	0.0157	0.00154	0.00931	0.0260
PBS	1 448	0.0135	0.000979	0.00881	0.0179
Diff (Baseline-PBS)		0.00224	0.00120		

Table D3-5 Summary of output from t-test to test the difference in fuel efficiency means between PBS and Baseline vehicles

Analysis Variable: Fuel efficiency				
Method	Variance	DF	t Value	Pr > t
Pooled t-test	Equal	2 199	41.54	<.0001
Satterthwaite t-test	Unequal	1 077	36.30	<.0001

Table D3-6 Fuel efficiencies of Timber Logistics Services' PBS and baseline vehicles operating in similar areas in KwaZulu-Natal, July – September 2013

Area	Vehicle Category	No of trips	Distance travelled (km)	Ave Round Trip (kms)	Ave. Payload (tons)	Fuel consumption (ℓ)	Fuel consumption ℓ/100kms	Fuel efficiency ℓ/ton.km
Highflats	PBS	352	70 547	200	45.50	42 043	59.6	0.0131
	Baseline	319	60 408	189	36.98	33 979	56.2	0.0152
Glenbain	PBS	107	31 370	293	45.73	19 434	161.4	0.0135
	Baseline	206	59 356	288	38.19	34 216	173.5	0.0151
Seven Oaks	PBS	255	83 663	328	45.50	49 994	167.3	0.0131
	Baseline	258	80 413	312	37.86	43 186	186.2	0.0142
Richmond	PBS	147	37 298	254	45.49	20 645	180.7	0.0122
	Baseline	589	153 529	261	36.30	81 412	188.6	0.0146
Sutton	PBS	544	133 726	246	45.71	76 534	174.7	0.0125
	Baseline	240	57 400	239	38.45	31 420	182.7	0.0142
Totals	PBS	1 405	356 604	254	45.60	208 650	170.9	0.0128
	Baseline	1 612	411 106	255	37.25	224 213	183.4	0.0146

APPENDIX D4

Payload efficiency metadata

Table D4-1 Payload Efficiency Factors of typical South African forestry baseline and PBS vehicles

Vehicle description	Overall length (m)	PMCM (tons)	Payload (tons)	PEF (%)
5-axle baseline	18.5	43.20	28.15	65.2
6-axle baseline	18.5	49.20	31.90	64.8
7-axle baseline	22.0	56.00	38.50	68.8
7-axle baseline	22.0	56.00	39.30	70.2
7-axle baseline	22.0	56.00	40.40	72.1
8-axle PBS	22.0	63.00	45.25	71.8
8-axle PBS	24.0	64.00	45.20	70.6
8-axle PBS	25.1	67.00	48.00	71.6
8-axle PBS	23.2	67.30	50.35	74.8
8-axle PBS	25.8	67.50	48.20	71.4
9-axle PBS	25.1	70.00	50.30	71.9

Table D4-2 Payload Efficiency Factors of typical forestry vehicles in Australia, Canada, New Zealand and Sweden

Country	Number of axles	Overall length (m)	PMCM (tons)	Payload (tons)	PEF (%)
Argentina	5	20.5	45	28	62.2
	5	20.5	45	30	66.7
Australia	6	18.5	43.20	28.15	65.2
	6	18.5	49.20	31.90	64.8
	7	22.0	56.00	38.50	68.8
	7	22.0	56.00	39.30	70.2
	7	22.0	56.00	40.40	72.1
	8	22.0	63.00	45.25	71.8
	9	24.0	64.00	45.20	70.6
	12	25.1	67.00	48.00	71.6
Brazil	7	20.5	60.00	40.00	66.7
	9	30.0	74.00	52.00	70.3
Canada	5	23.0	43.10	25.45	59.0
	6	23.0	51.10	32.45	63.5
	6	23.0	48.30	32.60	67.5
	6	23.0	52.20	33.55	64.3
	7	23.0	56.30	39.80	70.7
	7	23.0	60.10	39.65	66.0
	7	23.0	54.70	40.40	73.9
	7	23.0	61.30	39.75	64.8
Chile	8	27.5	63.50	45.00	70.9
	6	20.0	45.00	28.00	62.2
New Zealand	6	22.0	43.00	29.00	67.4
	7	22.0	44.00	29.50	67.0
	7	22.0	44.00	29.50	67.0
	8	22.0	44.00	28.50	64.8
Sweden	7	25.3	60.00	38.70	64.5
	8	25.3	68.00	45.60	67.1
	9	24.0	74.00	49.10	66.4
	9	24.0	74.00	54.90	74.2
	10	27.0	80.00	53.50	66.9
	11/12	30.0	90.00	66.20	73.6
Uruguay	7	20.5	57.00	38.00	66.7

APPENDIX D5

Road wear assessment metadata

Table D5-1 Road wear assessment results for baseline and PBS vehicles in the forestry industry

Assessment date	Client	Operator	Vehicle description	Overall length (m)	Combination mass (tons)	Payload (tons)	Average LEF/vehicle	Average LEF/ton payload
Nov-07			5-axle baseline	18.5	43.20	28.15	7.34	0.261
			6-axle baseline	18.5	49.20	31.90	7.62	0.239
			7-axle baseline	22.0	56.00	38.50	8.5	0.221
Nov-07	Sappi	Timber 24	PBS-F01	25.76	67.50	48.20	8.99	0.187
Dec-07	Mondi	Super Group	PBS-F02	24.0	64.25	45.20	9.11	0.202
Sep-09	Sappi	TLS ¹	PBS-F03	25.76	67.50	48.20	8.99	0.187
Sep-11	Sappi	TLS ¹ / Buhle Betfu	Baseline-F04	22.0	56.00	40.40	7.46	0.185
May-12			PBS-F04	25.62	67.50	48.20	9.04	0.188
Jun-12	Mondi	Timber-nology/ Gaskells/ Unitrans	Baseline-F05	22.0	56.00	39.30	7.8	0.198
			PBS-F05a	25.08	70.00	50.84	9.8	0.193
			PBS-F05b	25.0	70.00	50.30	8.6	0.171
Nov-12	Sappi	Zabalaza Hauliers	Baseline-F06	22.0	56.00	39.30	7.85	0.200
			PBS-F06	22.8	67.50	50.06	9.4	0.188
Nov-12	Sappi	TLS ¹	Baseline-F07	22.0	56.00	40.40	7.46	0.185
			PBS-F07	23.18	67.30	50.35	9.18	0.182
May-13	Mondi	Timber-nology	Baseline-F08	22.0	56.00	40.00	7.39	0.185
			PBS-F08	22.0	63.00	45.25	8.32	0.184

Note: ¹ Timber Logistics Services

Table D5-2 Road wear assessment results for baseline and PBS vehicles in the mining industry

Assessment date	Operator	Commodity	Vehicle description	Overall length (m)	Combination mass (tons)	Payload (tons)	Average LEF/vehicle	Average LEF/ton payload
Feb-12	Unitrans (Richards Bay Minerals)	Heavy Metal Concentrate	Baseline-M01	34.95	145.10	105.00	35.75	0.34
Feb-12			PBS (single tyres)-M01	42.67	174.10	122.30	43.17	0.353
Feb-12			PBS (dual tyres)-M01a	42.67	174.10	120.80	18.87	0.156
Jun-13			PBS (dual tyres)-M01b	42.67	185.00	132.72	20.92	0.158
Apr-13	Unitrans (Loeriesfontein)	Gypsum	Baseline-M02	22.00	56.00	37.34	18.19	0.487
			PBS-M02	40.48	148.00	98.90	17.23	0.174
Nov-12	Unitrans (Namakwa Sands)	Heavy Metal Concentrate	Baseline-M03	22.00	95.50	66.00	11.18	0.169
			PBS-M03	31.29	121.25	82.00	11.93	0.145
Nov-12	Unitrans (Empanjeni)	Various	Baseline-M04	21.27	56.00	37.34	13.95	0.374
			PBS-M04	20.54	73.25	46.00	7.99	0.174
Jun-12	Ngululu Bulk Carriers	Chrome ore	Baseline-M05	22.00	56.00	38.45	6.56	0.171
			PBS-M05	21.53	71.90	49.87	6.96	0.140
Aug-13	Barlo-world Logistics	Platinum concentrate	Baseline-M06	22.00	56.00	35.64	16.14	0.453
			PBS-M06	22.00	72.00	45.95	7.14	0.155
Apr-13	Barlo-world Logistics	Cement	Baseline-M07	22.00	56.00	40.76	16.77	0.411
			PBS ver 1-M07a	22.00	77.16	57.26	9.14	0.160
			PBS ver 2-M07b	22.00	70.63	49.68	6.78	0.136

Table D5-3 Road wear assessment results for baseline and PBS vehicles in other industries (besides forestry and mining)

Assessment Date	Operator/Client	Commodity	Baseline/PBS vehicle	Overall length (m)	Combination mass (tons)	Payload (kg)	PEF	Ave. LEF/vehicle	Ave. LEF/ton payload
Mar-12	Beefmaster	Beef cattle	Baseline	22.00	56.00	29.57	0.53	5.71	0.193
			PBS	31.40	72.17	34.09	0.47	6.73	0.197
Mar-12	Blackthorn	Processed sugar	Baseline	22.00	56.00	34.87	0.62	10.86	0.311
			PBS (single)	22.00	65.00	43.41	0.67	14.18	0.327
			PBS (dual)	22.00	65.00	42.81	0.66	7.11	0.166
Mar-13	Momentum Logistics	Containers (Wattle bark)	Baseline	22.00	56.00	33.55	0.60	5.55	0.165
			PBS	23.50	68.15	48.67	0.71	6.30	0.129
May-13	Buscor	Passengers	Baseline	22.00	56.00	38.45	0.69	7.80	0.203
			PBS (Merc)	21.53	71.90	49.87	0.69	8.70	0.174
Aug-13	Anderson Transport	Paper	Baseline	22.00	56.00	37.24	0.67	16.56	0.445
			PBS	24.73	73.00	50.50	0.69	7.73	0.153