

Characterization of the Direct Metal Laser Sintered Ti6Al4V Components

L. Chauke¹, K. Mutombo², C. Kgomo³

^{1,2,3}Material Science and Manufacturing/Light Metals, Council for Scientific and Industrial Research (CSIR), Pretoria, South Africa

¹lchauke@csir.co.za, ²kmutombo@csir.co.za,

Abstract

Tensile properties and hardness of the as received and heat treated samples were evaluated. Optical and scanning electron microscopy were used to investigate the microstructure of the as received and heat treated Ti6Al4V alloy. The as received sample showed a partial martensitic structure, with columnar grains, however α/β lamellar structure was observed in the heat treated. External and internal pores, un-melted or semi-melted powder particles and inclusions were observed in direct metal laser sintered (DMLS) Ti6Al4V component. The as received DMLS sample showed high ultimate strength and percentage elongation than the heat treated. A ductile fracture mode was observed from the as received DMLS sample, however cleavage fracture was revealed on heat treated. Heating the DMLS component under vacuum led to internal pore-free component.

Keywords: Direct Metal Laser Sintering, Tensile properties, Ti6Al4V, heat treatment

1. Introduction

Production driven industries are always looking at a maximum production at lower costs. Traditional methods for producing titanium components are costly due to additional steps such as machinery, tapping and turning. Considering the conventional methods drawbacks, additive manufacturing technology has tremendously gained interest in the metal parts production. The term additive manufacturing refers to technologies that create objects through a sequential layering process. One of the additive manufacturing techniques is the Direct Metal Laser Sintering (DMLS). DMLS has the capabilities of producing near-net shape components directly in a single process [2]. This process is based on a sintering mechanism involving semi or total melting of the powder. DMLS can be divided into two different methods: i) powder deposit and ii) powder bed method. The different from the two methods is that from the powder deposit method the powder is melted and deposited layer by layer on a platform, while from the powder bed the power source melts the powder on the bed platform layer by layer [3].

The manufactured component, using DMLS-wire feeding process, Shaped Metal deposition (SMD) or Selective Laser Melting (SLM) revealed epitaxial growth of columnar grains across layer bands. The microstructure consists of fully martensitic structure. Furthermore, the produced components exhibit process imperfections such as surface roughness, porosity, residual stresses, and layer bands [1, 4-8]. Those defects mainly affect the tensile properties, fatigue strength and crack growth [1, 5, 6]. Contrary to convention processed Ti6Al4V parts, the mechanical property optimization of the laser additive manufactured Ti6Al4V components need a specific heat treatment [1, 6]. The behaviour Ti6Al4V powder during the laser additive manufacturing and their effect on the surface finish, porosity and mechanical properties has been investigated by Seyda et al [9].

Still much work need to be done in terms of morphology, microstructure and defects generated, the effect of component flaws on the mechanical properties and the response of

the DMLS parts to the heat treatments. Hence, the objective of this investigation is to characterise and evaluate the heat treatment response of Ti-6Al-4V components produced using the DMLS method. Emphasis was made on internal and external flaws generated during layer by layer building

2. Experimental procedure

Ti6Al4V dog-borne sample produced by DMLS powder bed method is schematically shown in Figure 1. The EONSINT M270 equipment [10] was used for the production of dog-bone samples. The sample gauge length, breath and width are given in Figure 1. Tensile properties, hardness profile, microstructure analysis of the as received and heat treated samples were respectively studied using the INSTRON™ Servo Hydraulic 1342 test machine, microhardness Vickers tester (FM 700 equipped with an automatic computerised programme) and, optical and scanning electron microscope. The tensile fracture part was as well mounted, polished and etched using the conventional metallographic techniques for microhardness measurement and microstructural analysis.

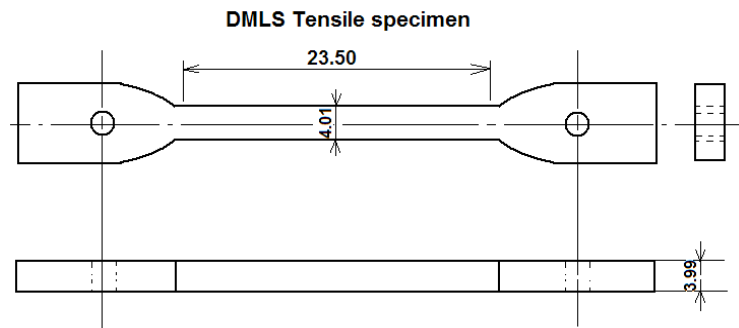

Figure 1: Dog-bone Ti6Al4V tensile specimen used for the study.

The heat treatment of the dog-borne shape samples was performed in the Zerion vertical vacuum furnace. The vacuum furnace has the capacity of 200 x200x 400 mm and equipped with a dual stage rotary vane pump. It can be run at the temperature range of room temperature to 1550°C, under base pressure of less than 10^{-5} mbar with a leak rate of less than 10^{-4} mbar/s. The Molybdenum resistance three zone systems is used for heating. The heat treatment parameters are given in Table 1.

Table 1: Heat treating parameters on the Ti-6Al-4V using vacuum furnace

Solution Temperature	Holding Time	Cooling Rate
1200°C	1200 minutes	Furnace cooling

The tensile fractured samples were analysed using the scanning electron microscope to investigate the failure mode and mechanism of DMLS components. The deformation behaviour in terms of softening and hardening was evaluated as well using the harness profile and the flow stress given by stress-strain curves. The analysis of internal and external flaws on the surface finish and fractures was performed using the scanning electron microscope (SEM)

3. Results and discussion

3.1. Microstructural analysis

The free surface characteristic and the cross-section of the as received Ti6Al4V alloy component produced by the DMLS process, is respectively shown in Figure 2a and 2b.

Unmelted and/or semi-melted particles and globules of Ti6Al4V featured the surface finish of the DMLS component. The component is covered by a semi-melted and porous layer of about 65 μm (Figure 2b). The surface finish is evidently rougher.

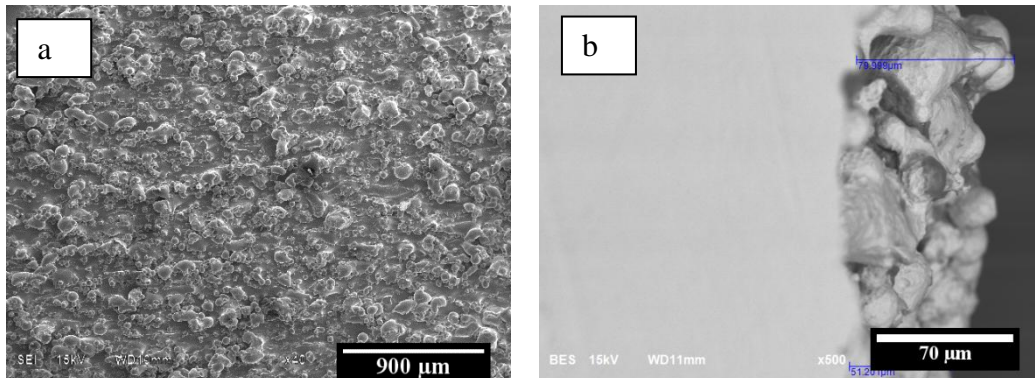

Figure 2. (a) Surface finish and, (b) cross-section of the as received Ti6Al4V DMLS component

This surface characteristic will affect the fatigue and the corrosion resistance the components. The as polished cross-section of the as received Ti64 DMLS component is in shown in Figure 3a and 3b. Two significant defects are revealed; the gas pores and inclusions. The gas pores are the results of the gas that is entrapped into the molten powder during the processing.

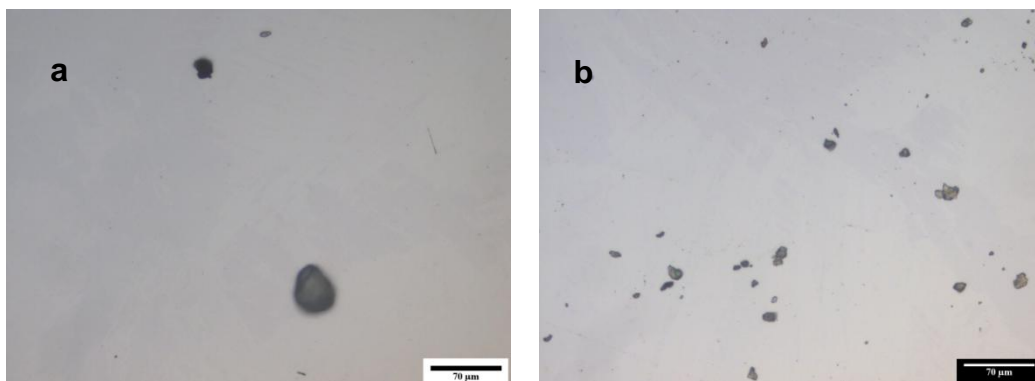

Figure 3. As polished cross-section showing, a) gas pores, and b) inclusions of the as received Ti6Al4V DMLS component.

The microstructure of the as received Ti64 DMLS component is shown in Figure 4a, 4b and 4c. The columnar grains are revealed in scanning and longitudinal direction of the component (Figure 4a and 4b), however fine equiaxed grains are in transverse section (Figure 4c). Evidently the DMLS produces anisotropic components. The mechanical properties will vary systematically depending on which direction the stress is applied. The as received DMLS component of Ti6Al4V alloy is a partial martensitic structure containing finer α/β lamellar, hexagonal (α') and orthorhombic (α'') martensite, and ordered alpha (α_2) [11]. However the heat treated revealed relatively larger equiaxed grains in all direction and containing α/β lamellar structure.

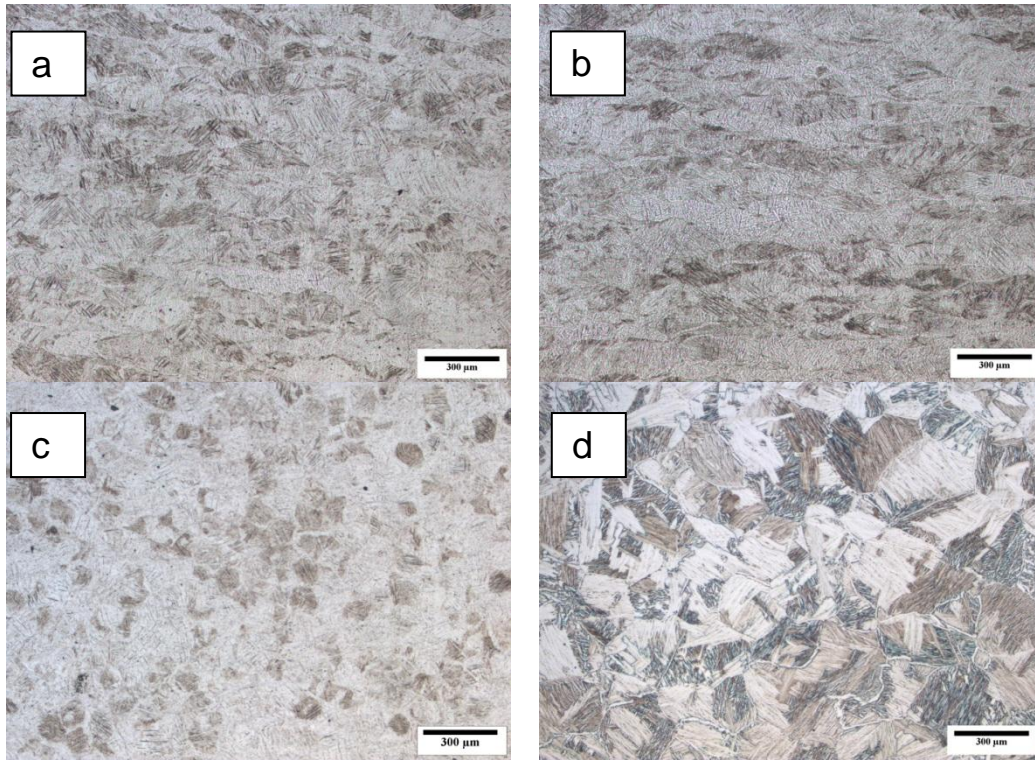

Figure 4. The microstructure of the as received DMLS component in a) scanning direction (SD), b) longitudinal direction (LD), and c) transverse direction (TD), and d) of the heat treated Ti64 DMLS sample.

3.2. Tensile properties and hardness

Tensile tests were performed using 50KN load cell INSTRON. The tensile test results are given in Table 1. The pulling stress was parallel to the scanning and longitudinal direction of the sample which is the favour direction; see Figure 4a, 4b and 4c. The resulting ultimate tensile strength (UTS), yielding stress (Y_s) and % elongation are relatively high compared to the heat treated tensile properties.

Table 1. The tensile properties of the as received and heat treated DMLS samples.

Sample condition	0.2% YS (MPa)	UTS (MPa)	% Elongation
As received	797.7	1043.3	15.0
Heat treated	661.0	690.1	1.9

The as received DMLS component showed higher resistance to deformation and higher toughness than the heat treated.

The hardness profile of the as received, heat treated Ti6Al4V DMLS samples, and their tensile fracture is shown in Figure 6. The heat treated samples showed high hardness than the as received DMLS. Surprisingly, lamellar structure component has lower hardness compared to the martensitic structure component obtained using a conventional route. The microhardness of the tensile fracture parts, of both as received or heat treated DMLS component, was relatively similar to their respective un-fractured samples.

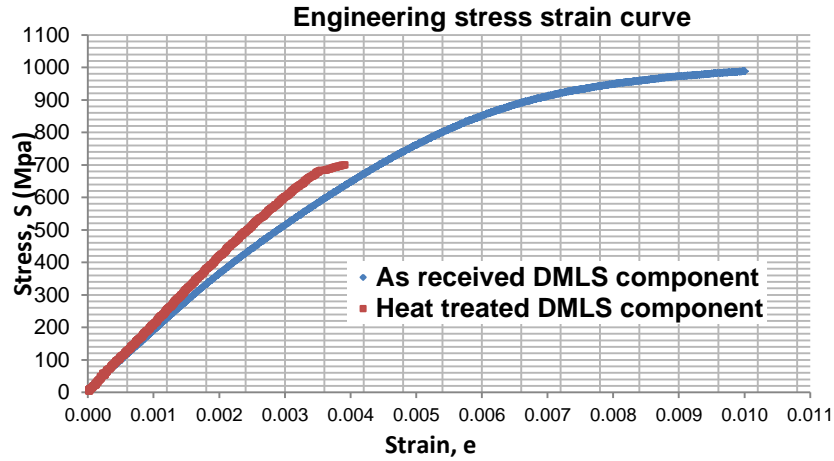

Figure 5. Stress-Strain curve of the as received and heat treated T6Al4V DMLS component.

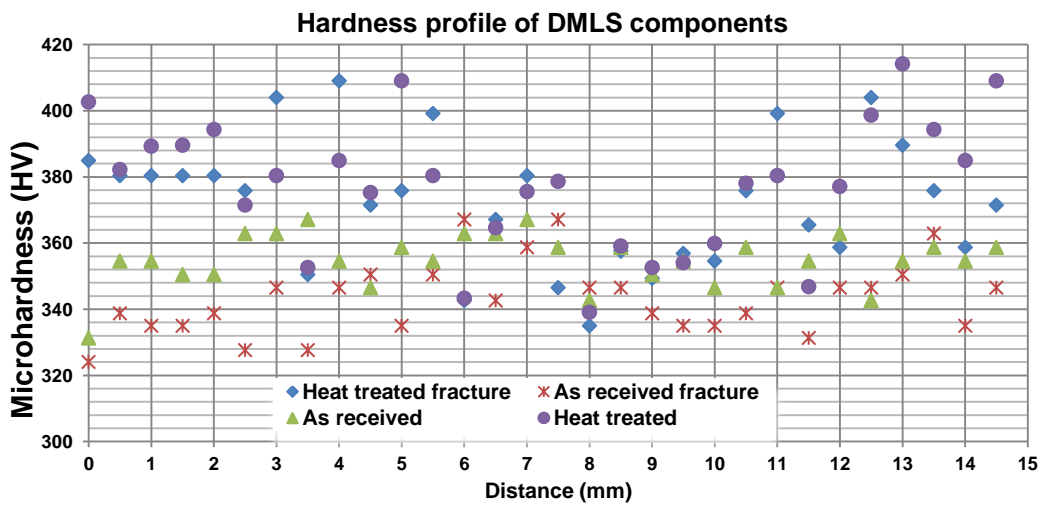

Figure 6: Hardness profile of the DMLS component in different conditions

3.3 Failure analysis

The tensile fractured surfaces of both as received and heat treated samples were analysed to investigate the failure mode and mechanism. SEM secondary electron images showing failure mode of the as received and heat treated samples are given respectively in Figure 7a and 7b. The fracture as received DMLS sample showed fine dimples like fracture (Figure 7a) which is evidently a ductile fracture, whereas the heat treated sample showed a cleave fracture (Figure 7b) which is a brittle fracture mode.

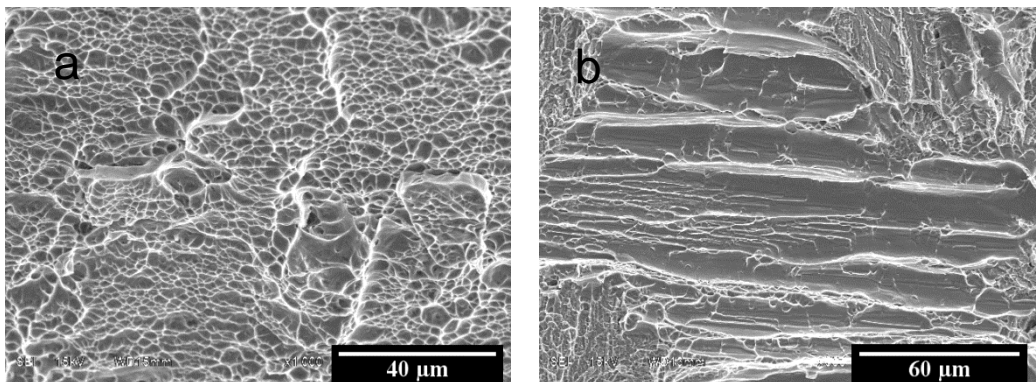

Figure 7. Fractured surfaces of (a) the as received; and (b) heat treated DMLS samples.

Internal defects of the DMLS component were revealed on the fracture surface as shown in Figures 8 and 9. Internal gas pores containing were present in the DLS as received samples (Figure 8a) However the DMLS sample heat treated under vacuum showed an internal pore-free fracture, as typically presented in Figure 8b. Most of internal gas pores were characterized by secondary cracks around the pore, and did contain some fine un-melted powder particles, as seen in Figure 9a.

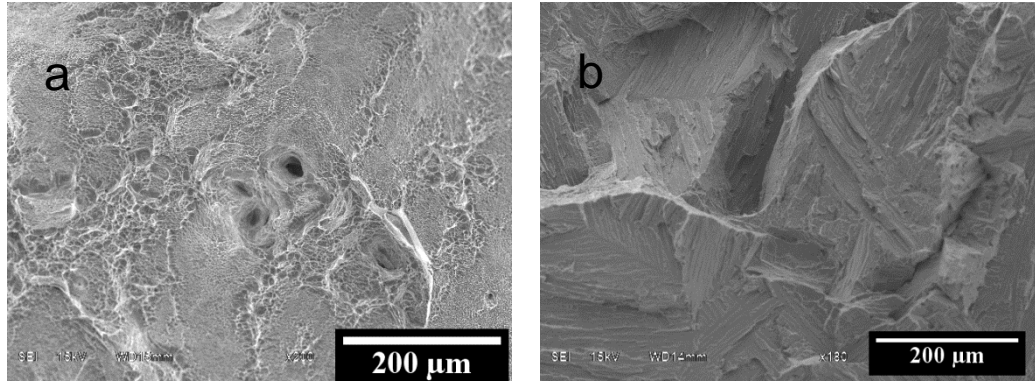

Figure 8. Fractured surfaces of (a) the as received containing gas pores; and (b) heat treated DMLS samples.

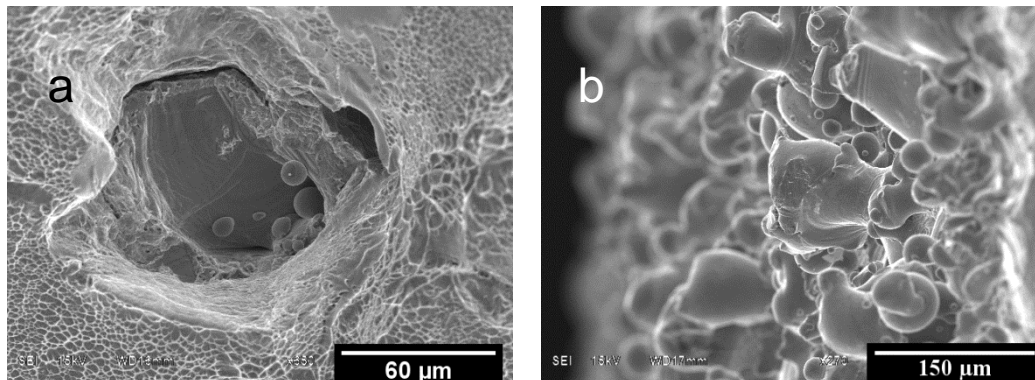

Figure 9. Fractured surfaces of (a) the as received, containing un-melted powder within a gas pore; and (b) outer porous layer showing pores and un-melted powder particles.

The outer porous layer of both as received and heat treated DMLS component is typically revealed on the fracture surface shown in Figure 9b. Most of the globules are intact from fracture, revealing un-melted powder particles and pores along a distance of about 400 µm.

Conclusions

The microstructural analysis, hardness and tensile testing of the as received and heat treated Ti6Al4V DMLS samples led to the following conclusions:

- The ultimate strength, yielding strength and percentage elongation are relatively higher,
- DMLS technique produces Ti6Al4V component which has columnar grain with partial martensite structure
- DMLS component contains flaws such as internal and external pores, un-melted or semi-melted powder particles, inclusions and surface finish with relatively high roughness.
- Heat treating the DMLS samples, under vacuum, leads to internal pore-free component, however the tensile properties are sensible reduced.

Acknowledgments

Authors acknowledge the technical and financial support of LM & NLC-CSIR (Light Metals & National Laser Centre-Council for Scientific and Industrial Research) and CUT (Central University of Technology).

References

1. B. Baufeld and Omer van der Biest, "Mechanical properties of Ti-6Al-4V specimen produced by shaped metal deposition", *Science and Technology of Advanced materials*, 2009 (10), 1-10.
2. D.E. Cooper, M. Stanford, K.A.Kibble and G.J. Gibbons, "Additive manufacturing for product improvement at Red Bull Technology", *Materials and Design*, 2012 (41), 226-230.
3. P.A.Kobry and S.L.Semiatin, "The additive manufacture of Ti-6Al-4V. *JOM*, 2001, 40-42.
4. E. Brandl, A. Schoberth, C. Leyens, "Morphology, microstructure and hardness of titanium (Ti-6Al-4V) blocks deposited by wire-feed additive layer manufacturing (ALM)", *Materials Science and Engineering A*, 2012 (532), 295-307.
5. S. Leuders, M. Thone, A. Riemer, T. Niendorf, T. Troster, H.A. Richard and H.j. Maier, "On the mechanical behaviour of titanium alloy Ti6Al4V manufactured by selective laser melting: Fatigue resistance and crack growth performance", *International Journal of Fatigue*, 2013 (48), 300-307.
6. B. Vrancken, L. Thijs, J.P. Kruth, T.V. Humbeek, "Heat treatment of Ti6Al4V produced by selective laser melting: Microstructure and mechanical properties", *Journal of alloys and Compounds*, 2013 (541) 177-185.
7. C. Sanz and V. Garcia Navas, "Structural integrity of direct metal laser sintered parts subjected to thermal and finishing treatments", *Journal of Materials Processing Technology*, 2013 (213) 2126-2136.
8. B. Song, S. Dong, B. Zhang, H. Liao and C. Coddet, " Effects of processing parameters on microstructure and mechanical property of selective laser melted Ti6Al4V", *Materials and Design*, 2013 (35) 120-125.
9. V. Seyda, N. Kaufmann, C. Emmelmann, "Investigation of aging processes of Ti-6Al-4V powder material in laser melting" *Physics Procedia* 2012(39) 425-431.
10. EDS GmgH, EoS Titanium and Titanium Ti64 ELI for EOSINT M270 System, Titanium version, 05-07.
11. K. Mutombo, N.E. Mazibuko, C. Siyasiya and W.E. Stumpf, "Phase evolution in Ti6Al4V alloy during thermal and thermo-mechanical treatment", *RAPDASA Conference*, 2012.