

NBRI

CI/SfB (90.41)	BG 11
UDC 712.2:625.8	

INTRODUCTORY GUIDE TO GARDEN PAVING

by *B.J. ADDIS*

Ook in Afrikaans verkrygbaar

Copyright 1980 NATIONAL BUILDING RESEARCH INSTITUTE
of the CSIR P O Box 395, Pretoria, 0001

INTRODUCTORY GUIDE TO GARDEN PAVING

INTRODUCTION

Paving is used to cover ground to eliminate dust, mud or erosion and to facilitate the movement of traffic. It can also be used to control the moisture content of the underlying soil around houses built on unstable soil such as heaving clay.

All too often paving is the 'Cinderella' of the home. This is a pity, as well constructed, functional and attractive paving will enhance any domestic property or garden.

This introductory guide to garden paving is intended for the layman. It discusses the design and construction for domestic use of:

- rigid concrete paving;
- unit paving (i.e. dry laid or ungrouted brick or block);
- concrete flagstone paving.

All these types of paving can generally be laid successfully by the 'do-it-yourself' householder. If properly constructed, they are extremely durable, virtually maintenance free and compare well in cost with other types of surfacing such as asphalt.

This guide gives suggestions on the geometrical aspects of paving design such as slopes and drainage. The three types of paving are compared, giving the advantages and disadvantages of each and factors to be considered in the choice of type of paving.

Information on sound practice as well as step-by-step descriptions of the construction of paving are included.

GEOMETRICAL ASPECTS OF PAVING DESIGN

To prevent the formation of puddles from rain or washing water, and the possible resultant softening of the underlying ground no paving should be absolutely horizontal. A slope of at least 1 in 50 (20 mm in 1 metre) should be provided to take water away from buildings or to stormwater drains. Note that it is illegal to discharge stormwater into municipal sewers.

Ramps for pedestrian access between various levels and to doorways should be provided in preference to steps, particularly for wheelbarrows, baby prams and for persons confined to wheelchairs. See Figure 1 for recommended slopes.

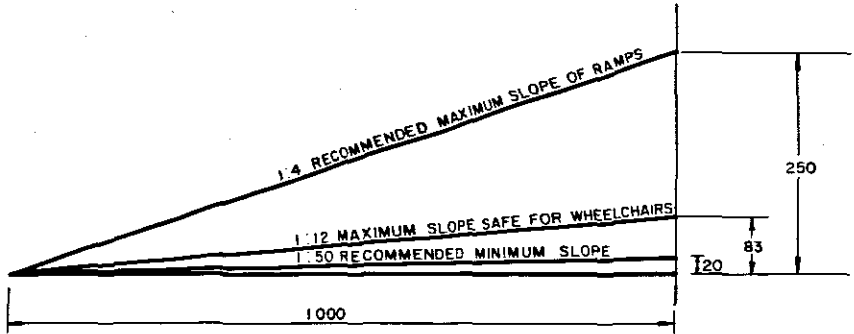

Figure 1 : Recommended slopes for paving

Paving should slope down from doorways; driveways should slope down towards the street if possible. Sudden changes of slope should be avoided particularly if the paving is to be used by vehicles.

Surface texture, particularly on ramps, should be rough enough to be slip-proof, even when wet.

COMPARISON OF PAVING TYPES

The essential differences between rigid concrete paving, unit paving and concrete flagstone paving are:

Rigid concrete paving consists of rigid panels or slabs of which the dimensions of the trafficable surface area are considerably larger than the thickness.

Unit paving consists of relatively smaller (brick size) units which are placed close together but not bonded to each other and which are able to move relative to surrounding units. This small degree of articulation gives the paving as a whole limited flexibility.

Concrete flagstone paving consists of precast slabs, usually 450 x 450 x 50 mm thick, placed close together but not bonded to each other. So, to some extent, concrete flagstone paving is also flexible.

Paving constructed according to the recommendations contained in this guide will have the capacity to carry loads of the following types:

Rigid concrete paving and unit paving are suitable for pedestrian traffic, and can carry passenger vehicles and light industrial vehicles (bakkies). *Concrete flagstone paving* is suitable for pedestrian use only.

It is suggested that vehicles be prevented from driving onto paving which is suitable only for pedestrian use and that heavier vehicles be prevented from driving onto any of the paving types described. Short posts or bollards spaced about 1 m apart will be adequate for the former purpose, while the provision of a pergola say 2 m high at the entrance from the street will keep heavy vehicles out of domestic driveways.

The advantages and disadvantages of each paving type are set out below and should be considered at the outset when deciding which type to use.

RIGID CONCRETE PAVING

Advantages

- high load bearing capacity when properly constructed.

Disadvantages

- limited aesthetic appeal;
- requires breaking up and subsequent repair if it covers underground services which have to be worked on.

UNIT PAVING

Advantages

- aesthetically pleasing to most people;
- work on underground services presents no problem - once the paving surface has been broken into, the units can be lifted and subsequently re-used; .
- localized impact damage is easy to repair;
- paving can flex to a certain extent without distress on unstable soil such as heaving clay;
- satisfactory load bearing capacity possible with sound construction;
- units can be re-used if necessary.

Disadvantages

- can become weed infested if not regularly trafficked or maintained.

CONCRETE FLAGSTONE PAVING

Advantages

- offers an opportunity to create a variety of visual effects with purpose made flagstones, either pigmented or with exposed aggregate finishes;
- work on underground services presents no problem as flagstones can be lifted and re-used;
- localized impact damage is fairly easy to repair;
- paving can flex to a certain extent without distress on unstable soil such as heaving clay;
- units can be re-used if necessary.

Disadvantages

- low loadbearing capacity;
- can become weed infested if not maintained.

The cost of materials and labour should also be considered. The relative cost of bricks, precast concrete blocks, precast concrete flagstones, cement, sand and stone varies from place to place, and the total cost per square metre of paving as well as for joints and edges if applicable should be calculated for the various methods. An example of a cost calculation is given in the appendix.

The cost of labour will depend on productivity, supervision, wages paid, equipment used etc. It is not possible to give a dependable indication of labour output or costs in this publications.

RIGID CONCRETE PAVING

STRUCTURAL REQUIREMENTS

To ensure adequate load carrying capacity and guard against cracking or subsidence, rigid concrete paving should be:

- cast on firm, solid and well drained ground;
- at least 75 mm thick, if cast in panels, or 90 mm thick, if cast in strips 600 mm wide;
- cast as panels not exceeding 2,7 m long or wide, or as strips with transverse joints spaced at between 1,0 m and 1,5 m apart;

made of high strength concrete (30 MPa at 28 days or equivalent) well compacted and cured.

CONSTRUCTION

EQUIPMENT

The following may be required:

- measuring tape - of steel or good quality cloth;
- string - preferably a heavy nylon fishing line;
- accurate spirit level;
- light straight edge (planed timber, for example, 70 mm x 20 mm x 3,0 m long);
- 2 kg hammer;
- steel pegs, say 12 mm diameter x 500 mm long, for setting out lines and levels;
- edge forms or casing - steel profiles or timber at least say 40 mm thick can be used;
- heavy steel pegs say 20 mm diameter x 300 mm long for holding formwork in position - thick pegs will offer more resistance to being pushed sideways into the ground by the pressure of wet concrete;
- picks and shovels - a mattock is useful for trimming the ground to the correct level;
- hand stamper;
- wheelbarrow(s);
- concrete mixer - hand mixing of concrete is only suitable for very small jobs, and the possibilities of hiring a concrete mixer or buying ready-mixed concrete should be considered;
- screed board(s) - these may be of 38 mm x 150 mm timber, steel or aluminium and should be longer than the width of the concrete panels; raised handles may be fitted to facilitate handling;
- plasterer's wooden float;
- plasterer's edging tool - a curved plate fitted with a handle - for forming the rounded corners at the edges and joints.

SETTING OUT

Using the measuring tape, spirit level, string and straight edge, mark out the location of joints, edges and levels of paving with light steel pegs driven into the ground. The tops of the pegs should indicate finished concrete levels.

Joints should be positioned so that the area to be paved is divided conveniently into panels of 2,7 m maximum width or length, or into strips 600 mm wide x 1,0 m to 1,5 m long. See Figure 2 for joint details.

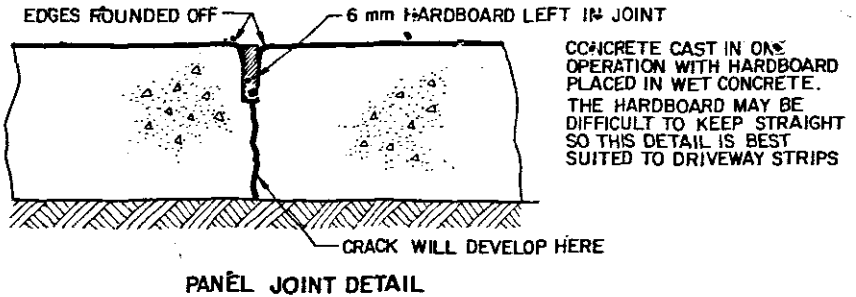
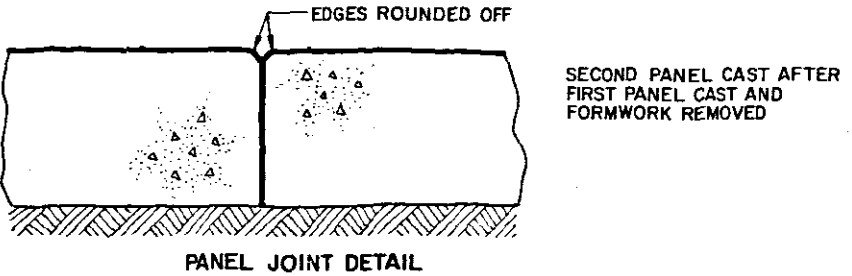
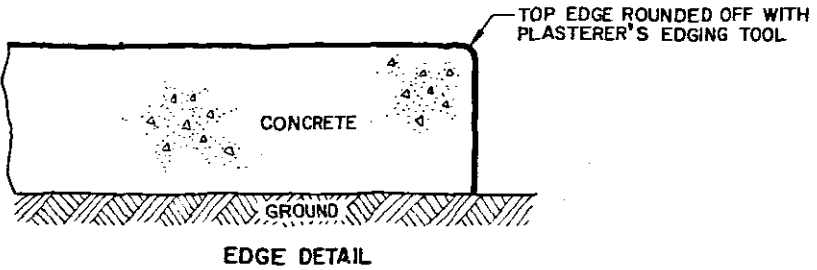

Figure 2 : Joint and edge details for rigid concrete paving

PREPARATION OF GROUND

The area to be paved should be excavated or filled as necessary to the correct levels. A gauge stick, the length of which equals the proposed concrete thickness, will be useful to check the ground levels - see figure 3. If the ground at the correct level is firm and solid, its bearing strength will be adequate. As a guide it can be assumed that ground which cannot be cut with a spade will be hard enough. Loose or soft areas must be dug out until firm ground is encountered. These areas together with low areas, must be filled with damp soil which is tamped firmly into place. Fill should be tamped in layers not exceeding 150 mm deep.

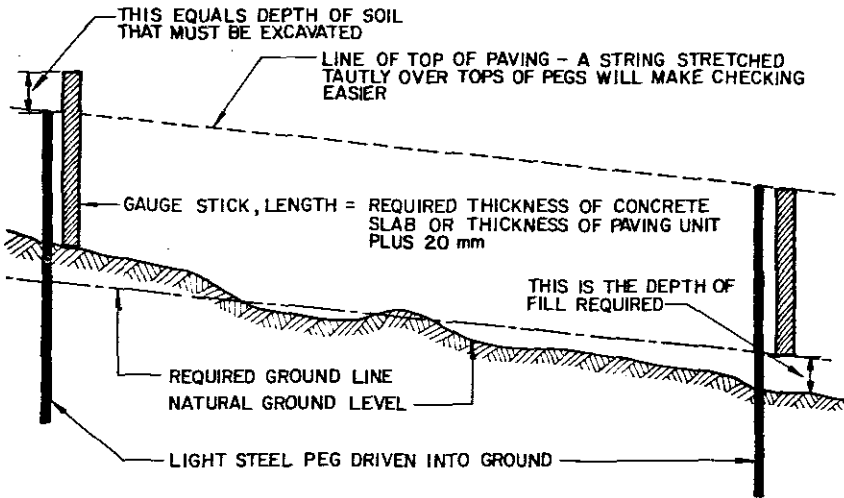

Figure 3 : The use of a gauge stick to check ground levels for paving

All vegetable matter such as grass, roots and tree stumps as well as all rubbish must be removed.

Where the soil has a high humus content it is recommended that it be excavated to a depth of 150 mm and replaced with subsoil or other suitable material and well compacted.

SETTING UP FORMWORK

It is usually impractical to trim the ground so accurately that the formwork can simply be placed on the ground with the top edge at the right height. The height of formwork should therefore be about 10 mm less than the required concrete thickness. The formwork may then be lifted to the correct elevation with small wedges or blocks - see Figure 4.

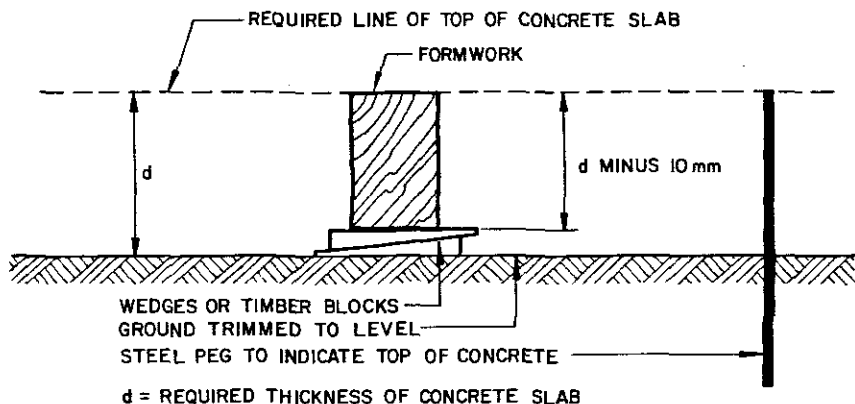

Figure 4 : Setting up of formwork to correct level

Heavy steel pegs must be driven into the ground on either side of the formwork. The pegs on the side away from the concrete will have to withstand the pressure of the wet concrete and should be placed at closer intervals than those on the concrete side. (See Figure 5.)

MIXING AND PLACING OF CONCRETE

Concrete may be obtained by:

- site mixing by hand or machine;
- buying ready-mixed concrete which is delivered to the site.

Hand mixing is extremely hard physical work and the concrete produced tends to be variable in quality. Hand mixing should therefore only be resorted to for the smallest of jobs. Hand mixing should be done on a clean, smooth surface and the ingredients mixed in the following order:

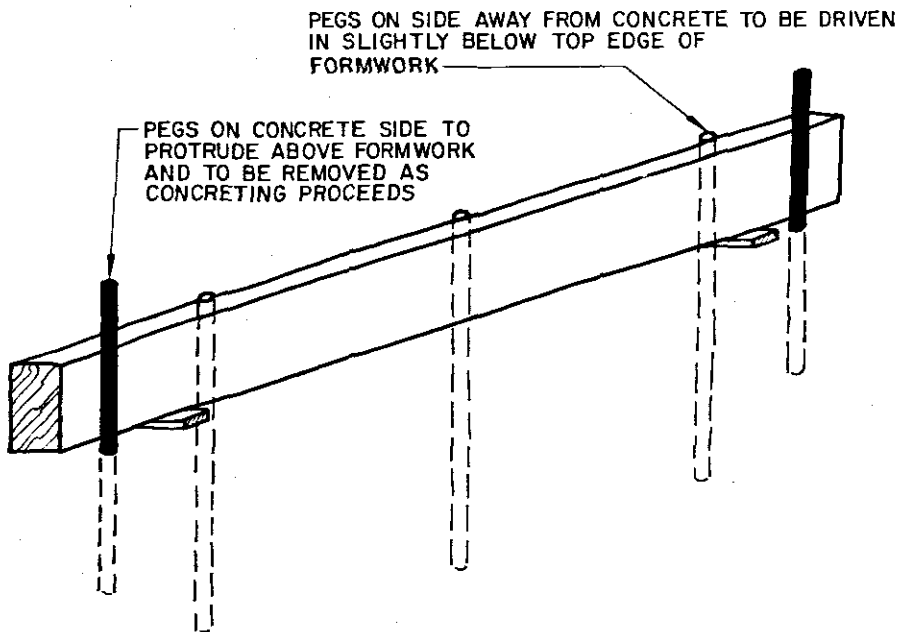

Figure 5 : Pegs to prevent sideways movement of formwork

1. mix sand and cement dry, until the colour is uniform;
2. mix in water and spread out about 60 mm thick;
3. scatter stone over and turn over to mix in.

Site mixed concrete containing 1 part of cement, to 2,4 parts of sand at normal moisture content and 2,7 parts of 20 mm nominal size stone, all measured by volume, may be used. All ingredients should be measured in the loose state. The sand and stone should be clean, hard, strong and durable; the sand should be graded from fine to coarse and the stone should preferably be of uniform size and not contain flat or elongated particles.

Only just enough water should be mixed into the dry cement and sand to produce a wet concrete with a plastic consistency that permits placing, especially into corners, without excessive spading or segregation (i.e. the separation of the ingredients) and allows easy finishing of the surface. Too little water will not permit good compaction while, too much will weaken the concrete and increase shrinkage and the likelihood of cracking.

Ready-mixed concrete is delivered in big quantities, and a large labour force, as well as the necessary formwork, is needed to enable the concrete to be placed and finished quickly before it begins to set. If ready-mixed concrete is ordered, a strength of 30 MPa at 28 days with 20 mm nominal stone and a slump of 85 to 100 mm should be specified.

The ground on which the concrete is to be cast should be slightly damp to prevent the mixing water in the concrete from being absorbed into the soil.

The concrete should be tipped onto the ground where needed, roughly levelled, and then compacted by tamping, removing the pegs in the concrete as this is proceeding. The more complete the compaction, the better will the concrete quality be.

After compaction the concrete should be struck off to the correct levels using a screed board which rides on the top of the formwork. The length of the screed board must be greater than the panel width. Areas that are too low will appear as hollows under the screed board and must be filled with concrete, compacted and struck off to the correct level. Striking off is the scraping away of concrete that is too high. (See Figure 6.)

Note that each panel should be cast in a continuous operation. If concreting is stopped for any length of time, uncontrolled cracking often takes place at the junction of old and new concrete.

After striking off the concrete, the surface must be finished to the desired texture while it is still plastic - that is, usually within 2 to 3 hours of mixing. A generally acceptable skid-resistant surface will be produced by wood floating.

The edges of the panel should preferably be rounded (see Figure 2) after the surface has been finished but while the concrete is still plastic. An edging tool may be used for this. Rounding the edges will improve the appearance and prevent much unsightly damage.

Note that a correctly proportioned and blended mix should produce a plastic surface that can be struck off and finished easily. It is not good practice to sprinkle neat cement or sand-cement mixture onto the surface to facilitate finishing, this impairs the quality of the concrete and often leads to early deterioration of the surface.

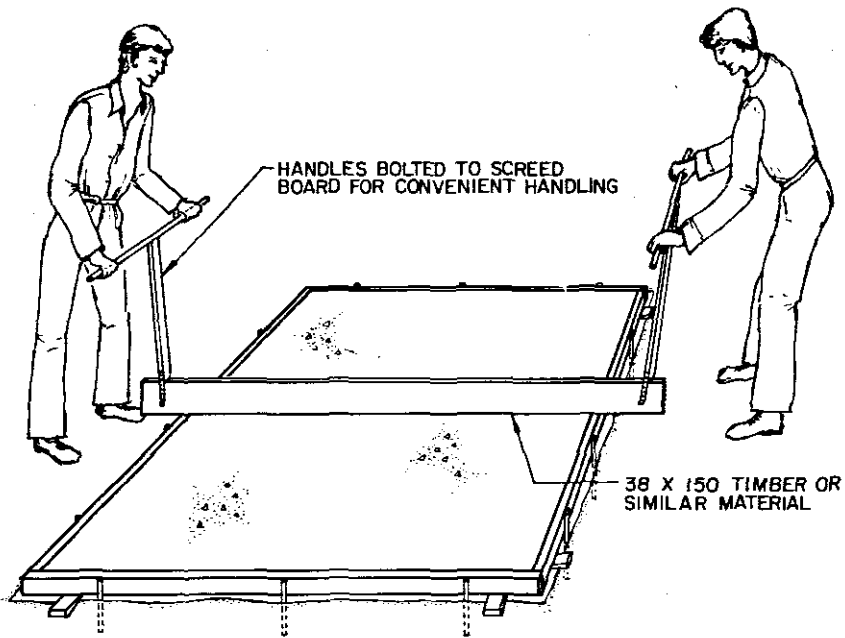

Figure 6 : Striking off concrete using screedboard

CURING OF CONCRETE

Effective curing is *ESSENTIAL* to ensure that the paving comes up to expectations. Curing should start as soon as the concrete has set so as to prevent the rapid drying out of the top layer. Covering the concrete with an impervious material such as polyethylene or other plastic sheet, or with an absorbent material such as hessian which is kept damp, is a practical and effective method. Curing should continue for seven days after casting.

Note that ponding or flooding as a method of curing will be impractical due to the slope of the paving and the inconvenience to further concreting operations. This practice can also saturate the ground which may consequently be weakened.

UNIT (BLOCK OR BRICK) PAVING

STRUCTURAL REQUIREMENTS

To obtain adequate load carrying capacity without subsidence or displacement unit paving should be:

- laid on a bed of compacted sand of even thickness over firm, solid and well drained ground;
- made of units (clay bricks or concrete blocks) which are hard, strong and of consistent size, laid tightly together with fine sand swept into the joints.

The performance of precast concrete block paving is generally superior to that of clay brick paving as precast concrete blocks are usually made to finer dimensional tolerances than bricks and produce paving with fewer and smaller gaps between units. Units made to interlocking patterns are also superior to rectangular blocks or bricks as they tend to work together more effectively under load.

MATERIALS

The sand used for the sand bed should be reasonably clean with the grain size preferably graded from fine to about 3 mm maximum although plaster sand will be adequate for small projects.

Bricks should be solid, hard-fired and made to close dimensional tolerances. They are usually laid flat but may also be laid on edge. Brick manufacturers will advise on the suitability of various bricks for paving.

Precast concrete paving blocks should be made of hard, dense, concrete and to close dimensional tolerances. If block strength is adequate, breakages should be minimal when a load is tipped from a truck. It is suggested that blocks be purchased from a reputable manufacturer who produces blocks which comply with a quality specification produced by the Concrete Masonry Association (South Africa).

Blocks, 60 mm thick and preferably of an interlocking pattern will be satisfactory.

CONSTRUCTION

EQUIPMENT

The following may be required:

- measuring tape - of steel or good quality cloth;
- string - preferably a heavy nylon fishing line;
- accurate spirit level;
- light straight edge (planed timber, for example, 70 mm x 20 mm x 3,0 m long);
- 2 kg hammer;
- steel pegs say 12 mm diameter x 500 mm long for setting out lines and levels;
- picks and shovels - a mattock is useful for trimming the ground to the correct level;
- hand stamper;
- light plate vibrator - optional but recommended - can be hired on a daily basis from plant hire firms in the larger centres;
- wheelbarrow(s);
- screedboard - 38 mm x 150 mm timber or similar;
- 20 mm water piping for temporary screed rails;
- bolster for use with 2 kg hammer to cut units;
- stiff bristle broom.

SETTING OUT

Using the measuring tape, spirit level, string and straight edge, mark out levels and edges of paving with light steel pegs driven in the ground. The tops of the pegs should indicate the final paving levels. Levels may also be indicated with pencil lines drawn on adjacent structures.

In practice, vertical curves may consist of a series of short straight lines.

The width of paving not contained between walls should be a multiple of half the length of a unit, plus twice the width of edge units if they are to be used. Manufacturers will supply unit dimensions.

Strip driveways are not practical in unit paving because of the measures necessary to provide edge restraint.

PREPARATION OF GROUND

The area to be paved should be excavated or filled to the correct levels. A gauge stick, the length of which equals the unit thickness plus 20 mm, will be useful to check the ground levels - see Figure 3.

If the ground at the correct level is firm and solid, its bearing strength will generally be adequate. Ground that cannot be cut with a spade will usually be hard enough. Loose or soft areas must be dug out until firm ground is encountered. These areas, together with low areas, must be filled with damp soil which is tamped firmly into place. Fill should be tamped in layers not exceeding 150 mm deep.

All rubbish and vegetable matter such as grass, roots and tree stumps must be removed from the soil.

Where the soil has a high humus content it is recommended that it be excavated to a depth of 150 mm and replaced with subsoil or other suitable material well compacted.

CONSTRUCTION OF EDGE RESTRAINTS

This should be done next. Suggested details are shown in Figure 7. Edge restraints must be constructed accurately to line and level.

PLACING THE SAND BED

Before placing the sand bed, the ground may be treated if required with a suitable soil insecticide to discourage ants or termites from undermining the paving. Insecticides of the aldrin or chlordane types will be suitable and should be applied according to the manufacturer's instructions.

Treatment of the ground with a herbicide before placing the sandbed is generally ineffective, as weeds tend to grow from seeds deposited on the paving surface.

Place the sand in a loose state and screed it off slightly higher than the final level required for the underside of the units; the extra height is determined by experience or by testing a small area by compacting the sand. The required

surcharge depends on the type and moisture content of the sand and is normally between 5 mm and 15 mm. The moisture content of the sand should be as uniform as possible.

NOTE : EDGES BUTTING AGAINST WALLS OR OTHER STRUCTURES NEED NO FURTHER RESTRAINT

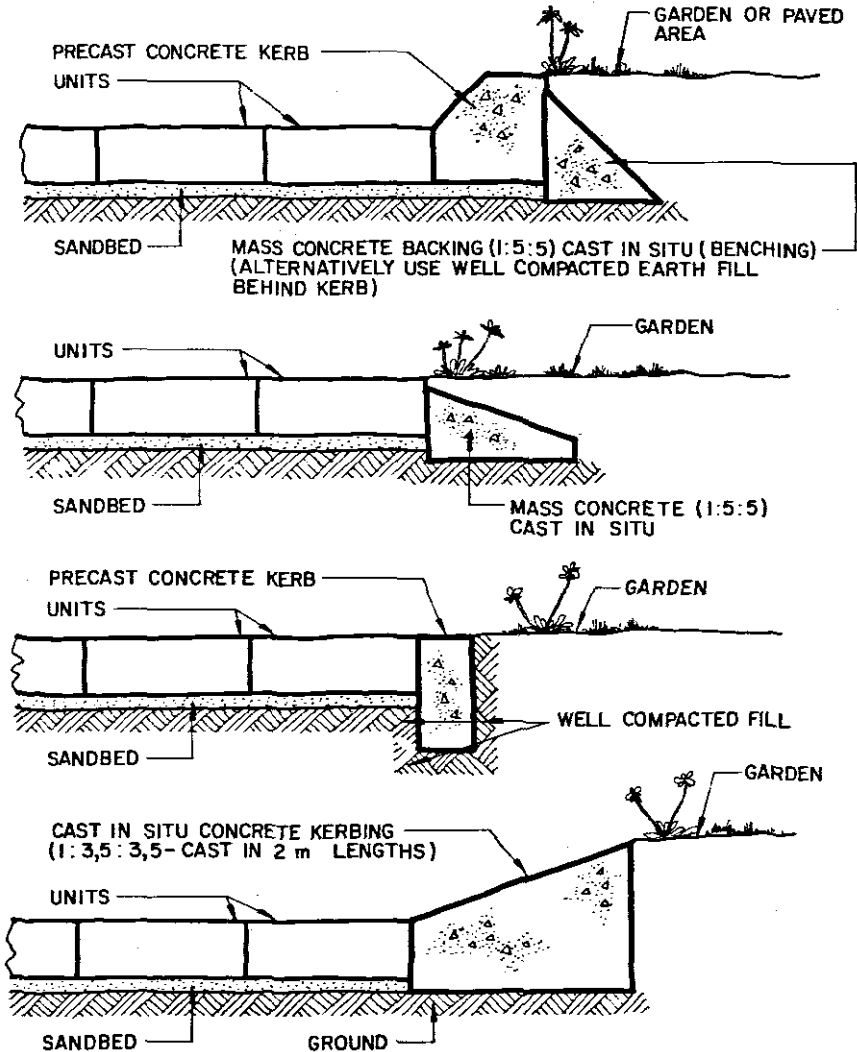

Figure 7 : Suggested edge details for unit paving

Screeding of the sand to the required levels is best done by using the tops of projecting kerbs as reference lines (see Figure 8) or on wide areas by setting up temporary screed rails on which the screed board can ride (see Figure 9).

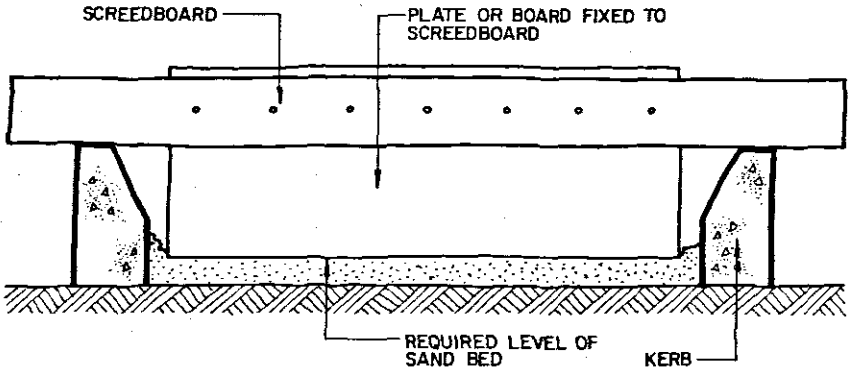

Figure 8 : The use of kerbs as reference levels for screeding the sand bed

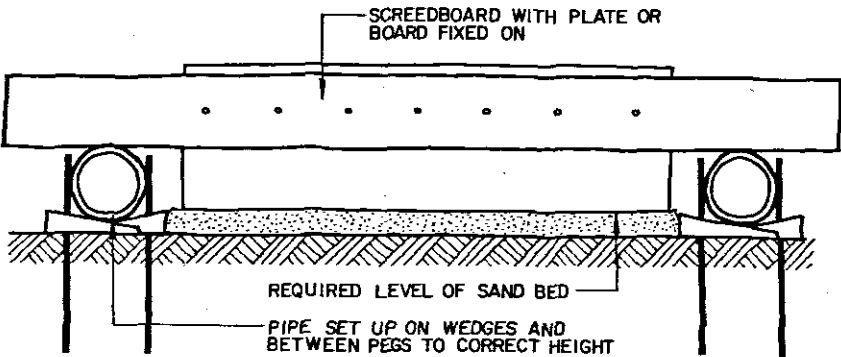

Figure 9 : The use of temporary guide rails for screeding the sand bed

It is important to avoid walking on the sand during spreading and screeding operations as this results in precompaction of the sand which produces an irregular final surface. This risk of disturbance is minimized if sand spreading and screeding are restricted to a short distance ahead of the unit laying face.

Setting out pegs must be removed or driven into the ground as screeding proceeds.

LAYING THE PAVING UNITS

The units are laid on the levelled sand bed to the required pattern such as herringbone or stretcher bond (see Figure 10). Units should be placed tightly against one another. (See Figure 11.)

Herringbone pattern results in better load bearing capacity than stretcher bond. Unit length must be twice unit width for herringbone pattern to work out. As clay bricks usually vary in size it is seldom possible to lay them to a neat herringbone pattern with tight joints. Clay bricks are therefore usually laid to stretcher bond, with the rows at right angles to the direction of traffic.

Curved line patterns should be avoided as they produce wide gaps between units which weaken the paving.

Some manufacturers of precast concrete paving blocks supply sets of blocks of diminishing size which form narrow wedge shapes which can be used to continue a stretcher bond pattern around horizontally curved sections.

Laying units with wide gaps between them and filling these gaps with mortar is not recommended as it can result in cracking in the joints and even of the units.

Small spaces which sometimes occur against kerbs or adjacent structures must be filled, preferably with pieces of unit cut to size. Spaces less than 40 mm wide must be temporarily filled with sand. Some clay bricks do not cut cleanly with a bolster and hammer, and spaces resulting from irregular cuts may also be temporarily filled with sand.

After laying the units, the sand bed must be compacted. This is done, preferably, by passing a light plate vibrator over the units - two or three passes will

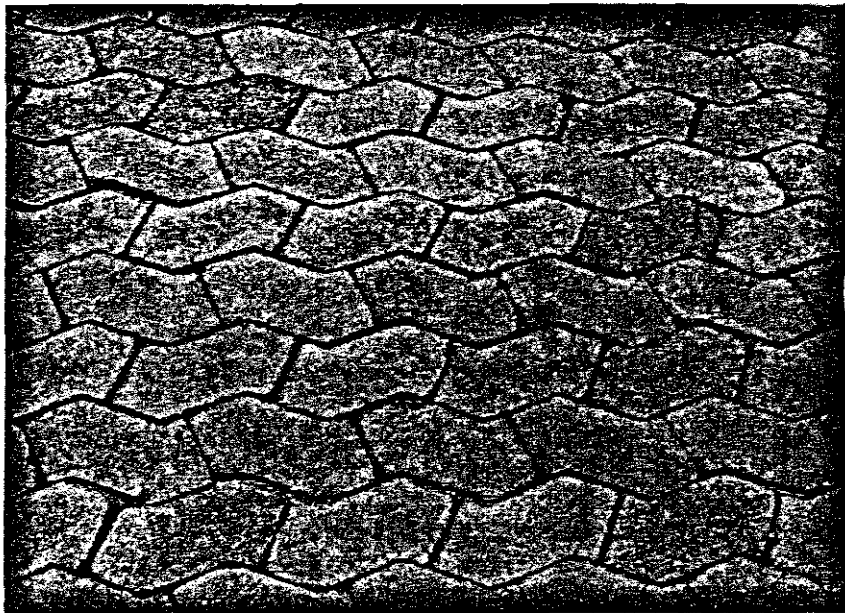

Stretcher bond

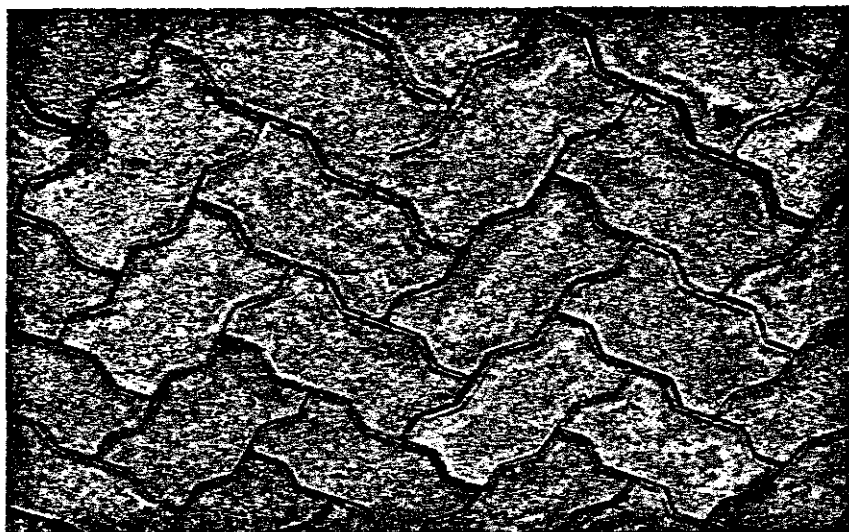

Herringbone pattern

Figure 10 : Patterns for unit paving



Figure 11 : Placing the units on the sand bed



Figure 12 - The use of a light plate vibrator to compact the sand bed

be sufficient (see Figure 12). If a plate vibrator is not available, and on small projects only, the units may be tapped down by striking a piece of timber, say 500 mm long x 150 mm wide x 38 mm thick, which is placed on the units, with a 2 kg hammer or the end of a pole say 75 mm diameter by 1,0 m long.

Whatever method is used, sand compaction should follow at least 1 metre behind the laying face.

If any units crack during the sand compaction process, they must be removed and replaced with sound units. When compaction has been completed, fine dry sand must be broomed into the gaps between blocks and the paving given one more pass with the plate vibrator.

Any temporary sand filling in spaces must now be removed. Spaces smaller than 40 mm wide should be filled with a mortar (1 cement to 4 coarse sand). Larger spaces should be filled with concrete (cement : sand : 20 mm stone =

1:2,4:2,7). Infill concrete of a contrasting colour may also be used for decorative effect.

Infill concrete or mortar should be cured for at least 3 days by keeping it damp.

To complete the paving, additional fine sand is carefully washed into the gaps and excess sand is removed from the surface.

The paving should not be subjected to traffic until the gaps between units have been properly filled.

CONCRETE FLAGSTONE PAVING

STRUCTURAL REQUIREMENTS

This type of paving is suitable for pedestrian traffic only. For satisfactory performance it should nevertheless be:

- constructed on reasonably firm ground that is well drained;
- made of good quality flagstones, approximately 50 mm thick and 450 x 450 mm square either obtained from a reputable manufacturer or made according to recommendations of the Portland Cement Institute.

CONSTRUCTION

The following may be required:

- measuring tape - of steel or good quality cloth;
- string - preferably a heavy nylon fishing line;
- accurate spirit level;
- light straight edge (planed timber, for example, 20 mm x 70 mm x 3 m long);
- pick and shovel;
- heavy timber dropper (say 75 mm diameter x 1 m long);
- light steel pegs for setting out;
- 2 kg hammer.

SETTING OUT

Using the measuring tape, spirit level string and straight edge, mark out edges of paving and levels with light pegs driven into the ground. The tops of pegs should indicate the finished paving level.

PREPARATION OF GROUND

The area to be paved should be excavated or filled in to about 50 mm below the required paving level. All vegetable matter such as grass, roots and tree stumps as well as rubbish must be removed. The top 50 mm of the ground need not be compacted but the ground below this layer should be reasonably firm. The next step is to loosen the top 50 mm of the ground breaking any clods as small as possible. Spread cement evenly over the area at the rate of one 50 kg pocket to 6 m² of ground, mix the cement and loose soil thoroughly, adding water until the mixture has a plastic consistency similar to toothpaste. Level the soil cement mixture roughly. Mixing should be done in fairly small sections, say 3 m² at a time, so that the soil cement does not harden before the flagstones are placed.

PLACING THE FLAGSTONES

The flagstones are placed in position one at a time and tapped down to the correct level using the timber dropper. The flagstones should settle into position without undue force if the soil cement is sufficiently plastic. Use the string or straight edge to check for level and edge alignment. Flagstones should be placed close together and the joints left without mortar filling. Do not walk on the paving until the soil cement has hardened say after 24 hours. Although the concrete flagstones may be laid between kerbs, edge restraint is not essential.

APPENDIX

EXAMPLES OF CALCULATION OF COMPARATIVE MATERIAL COSTS PER SQUARE METRE OF VARIOUS TYPES OF PAVING

Note that no allowance is made for wastage as the calculations are only comparative. It is suggested that quantities ordered be based on a 5 per cent wastage.

ASSUMPTIONS

Cost of materials	:	cement - R2,50 per 50 kg pocket	
per cubic metre		plaster	sand R5,00
		fairface bricks - R60 per 1 000	
		20 mm concrete stone - R8,00 per cubic metre;	
		coarse sand - R8,00 per cubic metre;	
		precast concrete flagstones 450 x 450 x 50 mm	
		- 70c each	
		grey precast concrete paving blocks 60 mm thick	
		- R3,80 per square metre;	
		concentrated soil insecticide R7,00 per litre.	

ALTERNATIVE A

RIGID CONCRETE PAVING IN PANELS

If volume batching is used and the mix proportions are 1 cement : 2,4 coarse sand : 2,7 stone size 20 mm, then the following approximate quantities of materials are required per cubic metre of concrete:

cement	8,1 pockets of 50 kg;
sand	0,65 cubic metre;
20 mm stone	0,73 cubic metre;

The material cost per cubic metre is therefore:

cement	8,1 x R2,50	=	20,25
sand	0,65 x R8,00	=	5,20
20 mm stone	0,73 x R8,00	=	5,84

R31,29

The material cost per square metre of 75 mm thick paving is therefore
 $R31,29 \times 0,075 = R2,35$.

ALTERNATIVE B

BRICK PAVING

If plaster sand is used for the sand bed which, when compacted, is 20 mm thick and the equivalent thickness of the sand between bricks is 5 mm, the cost of unwashed plaster sand per square metre, assuming that the sand compacts to about two thirds of its original volume, is $R5,00 \times 40 \div 1\ 000 = R0,20$.

If the flat faces of the bricks measure 215 mm x 100 mm, approximately 46 bricks will be used to pave 1 square metre. The cost of bricks is therefore $46 \div 1\ 000 \times R60,00 = R2,76$.

If a 1 per cent solution in water of the soil insecticide is used, 1 litre of the solution will cost $R7,00 \div 100 = R0,07$. If the application rate is 5 litres of solution per square metre, insecticide treatment will cost $5 \times R0,07 = R0,35$.

The material cost of brick paving per square metre is therefore:

sand	R0,20
bricks	R2,76
soil insecticide	R0,35
(optional)	-----
	R3,31

ALTERNATIVE C

PRECAST CONCRETE BLOCK PAVING

Sand bed and filler and soil insecticide will cost the same as alternative B.

The material cost of precast concrete block paving per square metre is therefore:

sand	R0,20
blocks	R3,80
soil insecticide	R0,35
(optional)	-----
	R4,35

ALTERNATIVE D

PRECAST CONCRETE FLAGSTONES

One pocket of cement covers 6 m^2 , therefore cost of cement per m^2 is $R2,50 \div 6 = R0,42$.

Flagstones are $450 \text{ mm} \times 450 \text{ mm}$, therefore approximately 5 are required per m^2 . The cost of flagstones is therefore $R0,70 \times 5 = R3,50$.

The material cost per square metre of precast concrete flagstone paving is therefore:

cement	R0,42
flagstones	R3,50

	R3,92

(If the flagstones were 'home made' their material cost would be about R1,60 per square metre, giving a total material cost of R2,02 per square metre.

SELECTED BIBLIOGRAPHY:

- *Introduction to concrete* ISBN 0 620 001 739. Published by the Portland Cement Institute, Kew Road, Richmond, Johannesburg 2092.
- *Concrete for the garden* ISBN 0 620 00462 2. Published by the Portland Cement Institute, Kew Road, Richmond, Johannesburg 2092.

NBRI INTRODUCTORY GUIDES

Other topics covered in this series are:

**NOISE
FOUNDATIONS
TEMPERATURE CONTROL
PAINTS AND PAINTINGS
DAMP IN BUILDINGS
SOLAR ENERGY
FLOORS AND FLOORING
SAVING ENERGY IN THE HOME
THATCHING
QUIET IN THE HOME**

All books in the NBRI Introductory Guide series are priced at 78c including gst and payment should be made when ordering.

Copies may be ordered from:

**The Director
National Building Research Institute of the CSIR
Box 395
PRETORIA
0001**