

Tangible interfaces for tangible robots

Andrew Cyrus Smith
CSIR's Meraka Institute
South Africa

1. Introduction

Various modes of tangible interfaces have been explored and researched. In this chapter we limit our look at tangible user interfaces to a subset of these. The subset is characterised by portability and no attached tethers, be they mechanical links or electrical wires. The subset does include tangible objects that are connected to a larger system for the purpose of relative position and orientation detection, if relevant. Such detection mechanisms include optical, magnetic, and radio means. Examples of optical detection are the use of fibre optics and a video camera. Magnetic detection utilises either the presence of a magnetic field, or the changes in such a field. Radio detection mechanisms include the use of the Global Positioning System (GPS) and radio frequency identification (RFID). Using electrically conductive pins provides for another untethered system.

Electrical field sensing and the use of acoustic waves are also covered in this chapter.

In our discussion we assume open-loop control of robot manipulators, that is, the user interface does not receive feedback from sensing subsystems. The user interface relies on other subsystems to check the inputs provided by the user interface with the actual position of the manipulator.

2. A Short Introduction to Tangible User Interfaces

In this section we introduce the novice to this exciting mode of interfacing to technologies. We look at the properties of known Tangible User Interfaces (TUI's) and how they have been applied in the real-world.

What are Tangible User Interfaces (TUI's)? The term TUI has been coined by Ullmer and Ishii in 1997 (Ullmer, 1997). This definition is somewhat restrictive in that the output is also reflected in the input device. An example of such a device is Tobopo. Tobogo is a physical device that will record the actions the user has taken on its various components. For example, if the user constructs a model dog and moves the various legs, the system will record the motions and replay them. It is quite possible to let the system modify the behaviour after being recorded, or show a response even during the recording.

In this chapter we look at a broader definition of TUI, similar to the relaxation of TUI's by others (Fisken, 2004). In the definition we address cubic objects that provide an input to

some system. The output is not manifested in the cubes as per the strict definition of TUI's. As applied to robot effectors, this implies that the output is visible through the change in the effectors' state. For the purpose of this chapter we prefer the broad script of TUI's as given in Fishkin2004. In this broad script we are concerned with an "input event", some system that "senses" the event and somehow responds to it, and some form of feedback initiated by the system which is called an "output event".

We base our interaction roles on those described elsewhere (Yanco, 2004). In the taxonomy of Yanco, five interaction roles are given. These are "a supervisory role", "an operator", "a teammate", "a mechanic", and "a bystander". The tangible interfaces we describe are best suited in the role of a supervisor. The supervisor constructs the series of actions that should be executed by the robot and then activates the programme represented by the cubes. The underlying system does not simply execute a number of steps, but has the ability to change the execution sequence based on inputs received from the actuators, the environment, or another system (Fig. 1.).

Some three dimensional TUI's are manipulated in a two-dimensional plane. Other TUI's have been developed that also work in three dimensional spaces, such as Tobopo, ActiveCubes, and SystemBlocks. Tobopo can be used as an autonomous system. ActiveCubes are used to sense and interface with other systems.

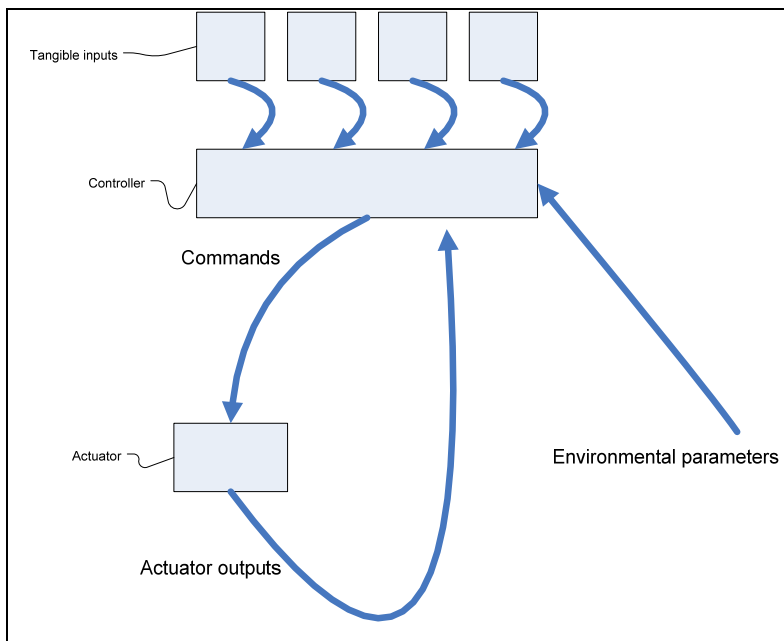

Fig. 1. Generic tangible system diagram

3. Why TUI and not GUI?

Ever since the electronic computer became a research tool the operator had to take care of the delicate input mechanisms available to interact with the computer. At first the

mechanisms available were switches and paper tape. These were followed by magnetic tape and paper punch cards. At this time output mechanisms evolved from paper tape and lights, to the two-dimensional cathode ray tube (CRT) display. Yet these output mechanisms are still two-dimensional. The information displayed on these displays has progressed from only textual to the incorporation of graphical elements. Over time the Graphical User Interface (GUI) has become familiar to all computer users. Yet some users still insist that the textual interface suits them the best. They claim that they are the most productive with such an interface. At the same time these users also make extensive use of the QWERTY keyboard to interact with the computer. They are professional computer system developers and make little use of the computer mouse, claiming that the keyboard shortcuts they are accustomed to empowers them more than using a mouse and the GUI. For the majority of computer users the GUI and mouse remains the most prominent interface to the electronic computer. There exists, however, a relatively new research field in which the manipulation of physical artefacts are considered as an alternative interface to the electronic computer. It can be argued that making use of tangible interaction with the computer, in addition to the GUI, increases the 'bandwidth' available to a user for interacting with the computer. An increased bandwidth allows for faster interaction. The use of gross motor skills, in addition to the fine motor skills required for operating a computer mouse, might be more 'natural' for some users.

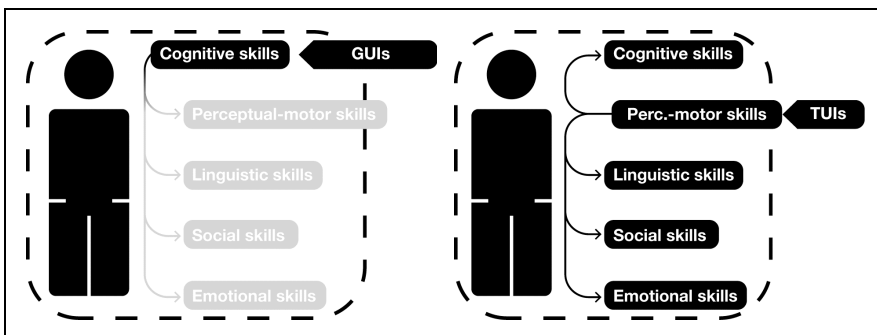

Fig. 2. Graphical User Interfaces address the user's cognitive skills. Tangible User Interfaces also incorporates the user's motor skills (Hegeveld 2009)

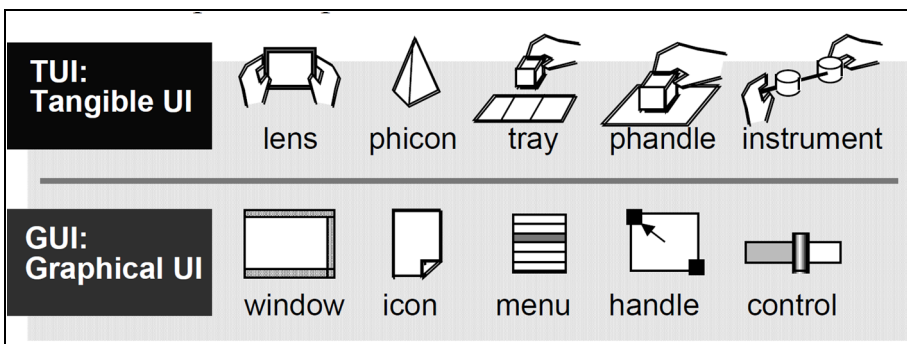

Fig. 3. TUI instantiations of GUI elements (Ullmer 1997)

In the physical world in which we use Tangible User Interfaces (TUI's), we can find similarities between the TUI's and the GUI's by extrapolating the two dimensional screen to the three dimensional physical world.

4. Limitations and Advantages of TUI's

TUI's have certain advantages and limitations compared to other technology interfaces. These advantaged and limitations are discussed in this section.

4.1 Limitations

Tangible User Interfaces have a number of disadvantages over conventional Graphical User Interfaces. These include storage of the constructed sequence, the space required for the sequence, how to make it persistent (as one would save a file to a hard disk), how to document it and transporting the constructed sequence.



Fig. 4. Transporting TUI sequences can be difficult (Horn 2009)

4.2 Advantages

Tangible User Interfaces can potentially be designed to be intuitive for the novice user (Fig. 5.), but potentially frustrating for an advanced user. A textual interface or an iconic interface could be presented to the advanced user as a possible solution.



Fig. 5. Tangicons (Scharf et al., 2008)

5. Data Coupling Mechanisms

5.1 Magnetic

Magnetic detection is possible using either mechanical switches or solid state detection circuitry. Figures 6 and 7 illustrate a system called GameBlocks which makes use of mechanical “reed” switches.

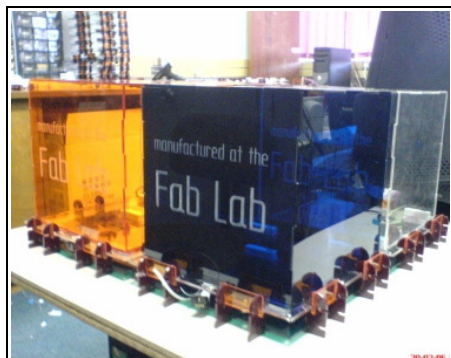

Fig. 6. GameBlocks (Smith 2007)



Fig. 7. GameBlocks (Smith 2009)

5.2 Electrical contact

Electrical contacts rely on direct physical contact between two or more electrically conductive components. A few examples follow.

AlgoBlocks

AlgoBlocks makes use of wide electrical connectors to distribute the data through the system.



Fig. 8. AlgoBlocks (Suzuki 1995)

FlowBlocks

FlowBlocks distributes data using the same magnets that are used to keep the various components together.

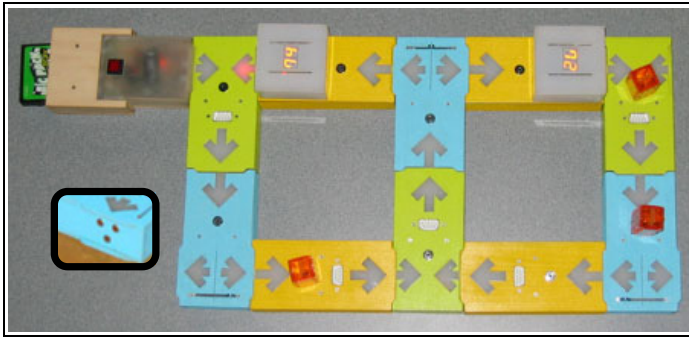

Fig. 9. Flowblocks are connected using magnets. The same magnets are also used to transfer data and power between the blocks. The insert shows three magnets at the end of one of the blocks. Magnets assist in aligning the blocks properly (Zuckerman 2005)

VIO controls

VIO controls make use of pins which consist of two parts each. One part runs along the inside of the other and is slightly longer than the outer sleeve. The longer length allows penetration to a second conductive layer which is located below the upper conductive layer. The sleeve makes contact with the upper layer only.

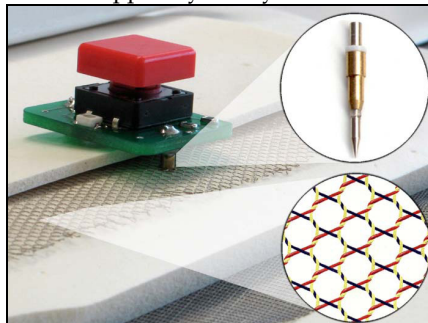

Fig. 10. VIO controls (Villar and Gellersen)

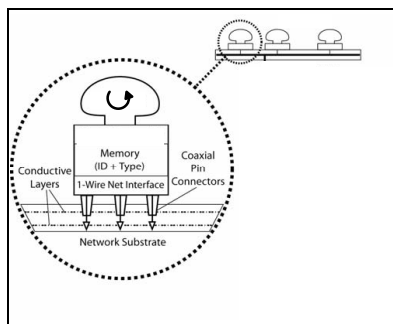

Fig. 11. The electrical configuration of VIO controls. (Adapted from Villar and Gellersen)



Fig. 12. An example of the VIO controls being applied

5.3 Optical: video camera from below

This approach makes use of bottom projection (Fig. 13.) with the video camera placed below the work surface. A configuration like this is convenient as it eliminates obscuration of both the projection and video recordings (Fig. 14.).

5.4 Optical: video camera from above

In the previous section an example is given of fiducial markers (Fig. 15.) placed at the bottom of the object being tracked. Another configuration is with the fiducial markers placed on top of the object to be tracked (Fig. 16.). Optional images are also projected from above the interaction surface.

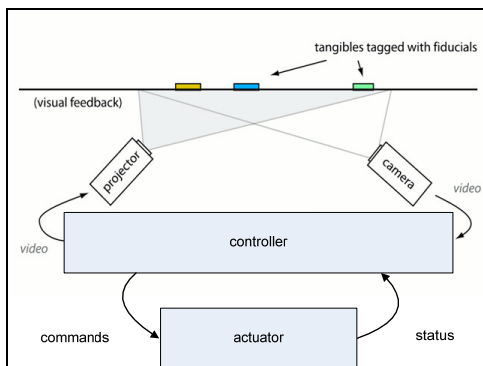

Fig. 13. Using tangibles tagged with fiducials to control and actuator. Visual feedback is provided by the projection below the transparent work surface (Adapted from Kaltenbrunner and Bencina)

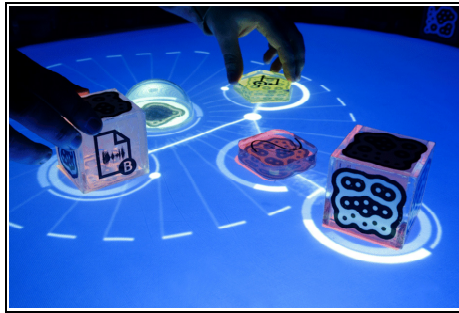

Fig. 14. Tangibles with fiducials and bottom projection are used to control a music synthesiser in a system called “reactTable”

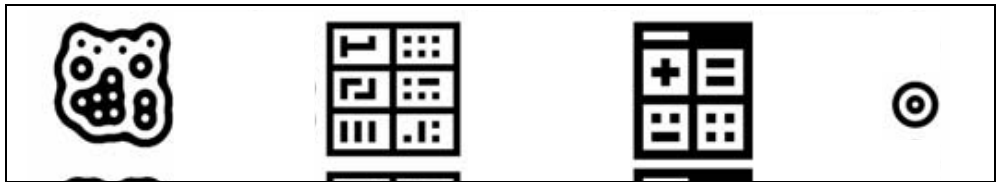

Fig. 15. Examples of fiducial marker types. The fiducial on the left is very compact. (Adapted from Kaltenbrunner and Bencina)

When using Illuminating Light (Fig. 17.), a software programme identifies the coloured dots and their patterns on the optical elements. A projector then adds additional information onto the work surface, such as the path of reflected light.

Tern (Fig. 18.) consists of a collection of interlocking pieces. Each piece has a unique optical pattern imprinted on the top which identifies the function of that piece.

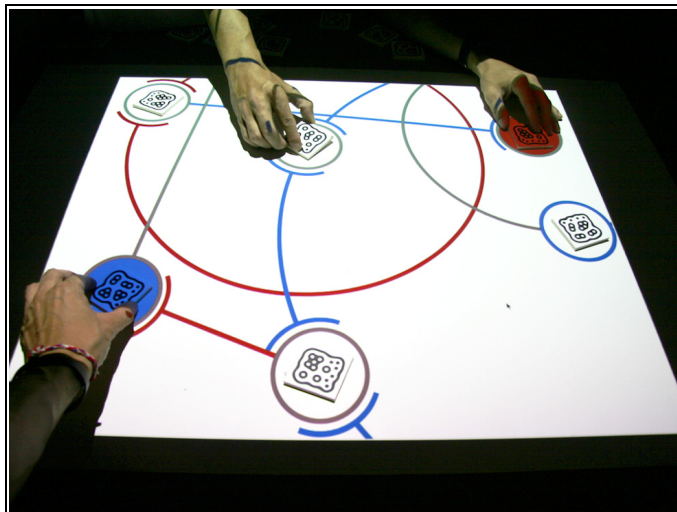

Fig. 16. Top camera and top projection (Kirton 2008)

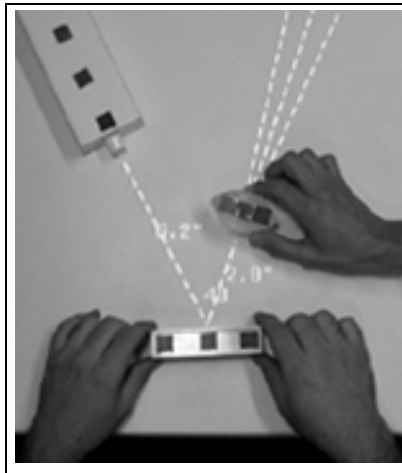

Fig. 17. Illuminating Light (Underkoffler 1999)



Fig. 18. This tangible interface consists of wooden blocks shaped like jigsaw puzzle pieces (Horn2009)

5.5 Optical: one dimensional

In contrast to the two-dimensional video camera communication mechanism described earlier in this chapter, we here present two examples of TUI systems that make use of a single light source that communicates between two blocks (Fig. 19, 20).

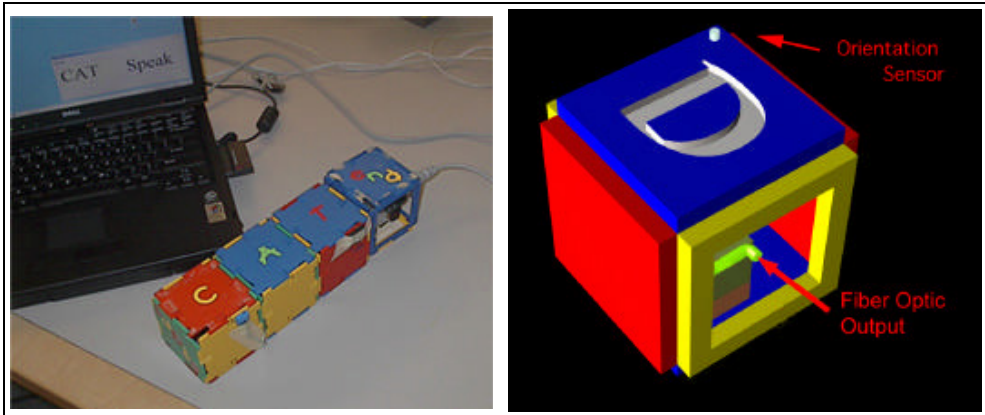

Fig. 19. Computational alphabet block (Eisenberg 2002)



Fig. 20. Using the Navigation Blocks to construct disjunctions and negations. Left: “or” query. Middle: “and” query. Right: “not” query (Camarata 2002)

5.6 Acoustic sensing

The acoustic table (Fig. 21.) consists of a number of acoustic transmitters which are used to ‘illuminate’ the surface of the interaction area. The objects to be detected contain circuitry that responds to the “illumination” by transmitting infrared signals to a set of infrared detectors around the table.

5.7 Induction sensing

Induction sensing systems (Fig. 22.) make use of low frequency alternating current flowing through a wire grid. The objects to be sensed contain their own inductive and capacitive circuits which resonates at a pre-determined frequency. If the sensing surface is stimulated at the same frequency at which the object to be sensed has been tuned, the object will be detected.

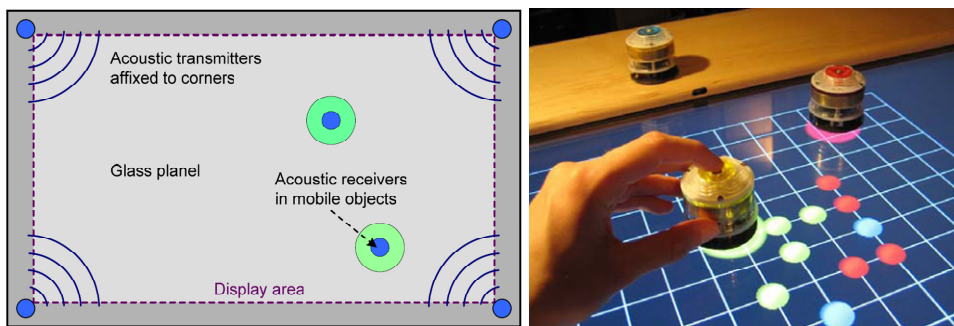

Fig. 21. Acoustic table (Mazalek)

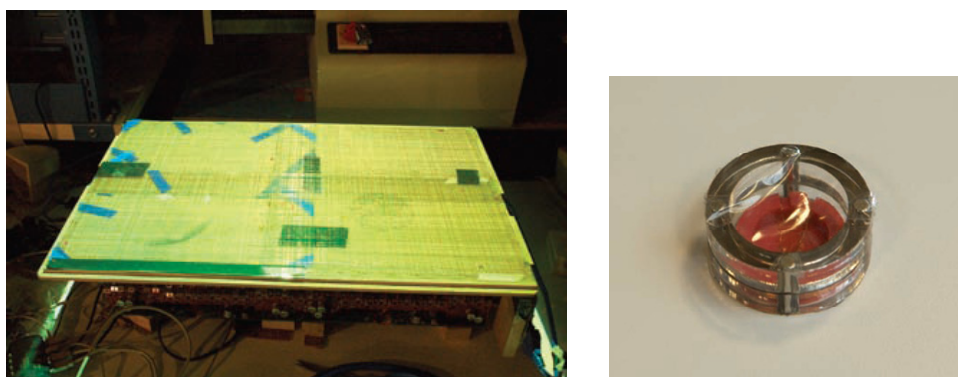

Fig. 22. Several modified sensing antennas and LC tag (Patten 2005)

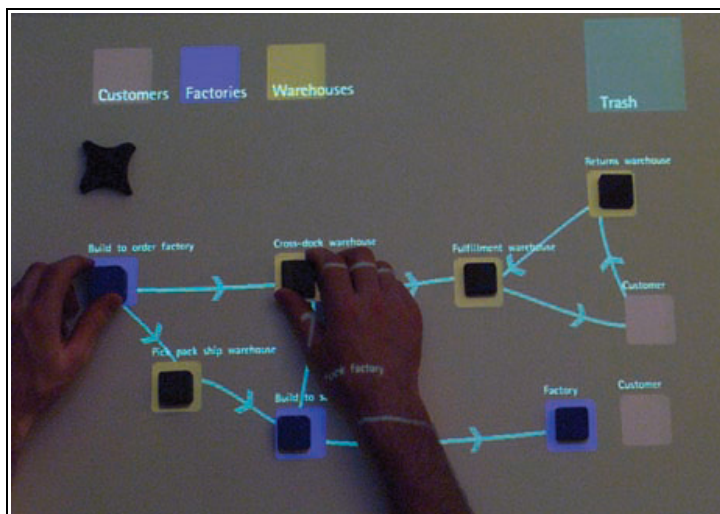

Fig. 23. Resonant table in use with overhead projection (Patten 2005)

6. Other TUI's

We have not covered the multitude of possible sensing and construction mechanisms. In this section we simply provide a few more interesting examples.

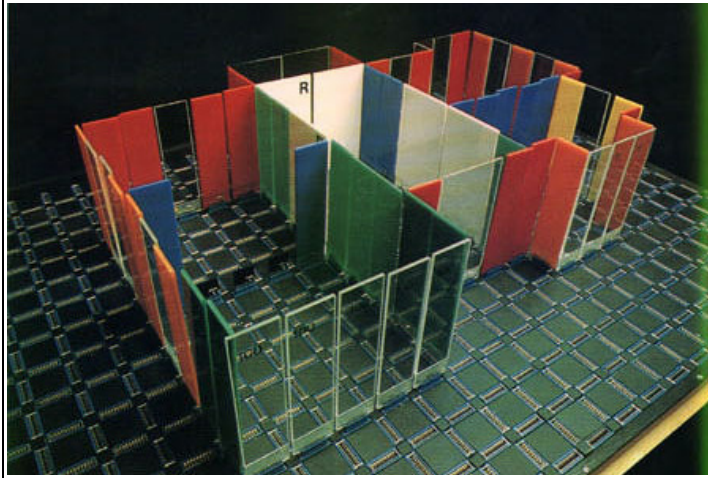

Fig. 24. Grid-restricted tangibles (Frazer 1995)

The following TUI's are not restricted to a surface for assembly. They operate independently of a surface and can be manipulated in the hand of the user while in operation.

6.1 Tobopo

Topobo (Fig. 25.) consists of a number of building elements, most of which contain electrical circuits.

Some elements serve as sensors, others as actuators. What makes Tobopo unique is that some building elements contain both a sensing circuitry and actuators. As an example, if the user rotates the shaft of a motor element, the Tobopo system can record that action and on command 'replay' the action.

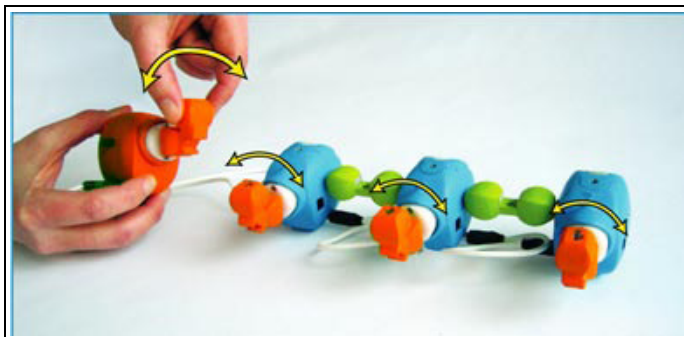

Fig. 25. Tobopo programming and replay (Raffle 2008)

6.2 SystemBlocks

SystemsBlocks (Fig. 26.) consists of a number of objects with embedded electronic circuitry. These augmented objects are interconnected using electrical wires through which data flows.

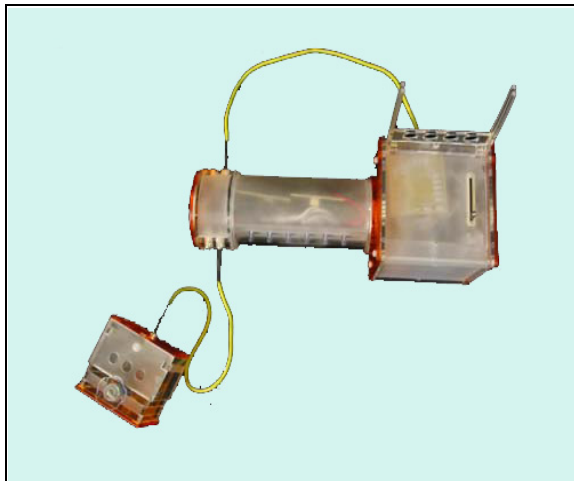

Fig. 26. SystemBlocks are interconnected using electrical wires (Zuckerman 2004)

6.3 ActiveCube

ActiveCube (Fig. 27.) is a system comprising of various cubes, each containing an electric circuit specific to the cube's intended function. The cubes are custom designed to serve as either sensors or actuators. Examples of sensor cubes are a sound processor, an infrared sensor, a gyroscopic sensor, a tactile sensor, and an ultrasonic sensor. Examples of actuator cubes are a motor, a buzzer, a vibrator, and a light. Activecubes are snapped together using the four clothing fasteners on each of the six cube surfaces. These fasteners are also used for transferring data between the cubes.

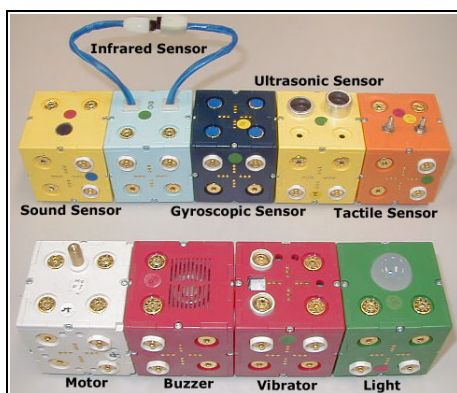

Fig. 27. ActiveCube (WATANABE 2004)

7. Tangible Interfaces Research at the CSIR's Meraka Institute

In the research described in the above sections, little or no consideration has been given to the costs involved in creating the tangible interfaces. A different approach is followed at the CSIR's Meraka Institute.

The Institute is located in the developing region of Southern Africa where access to funding is limited, perhaps more so than in developed regions where the research covered above is taking place. As a result the cost of technology is considered a very important system component. To achieve the objective of affordable Tangible Interfaces for developing regions, the Institute explores various materials and technologies. In all its research to date, the Institute has made use of low cost electronic components for interfacing the tangible objects to toy robotic devices (Smith, 2008).

The approach followed at the Institute, which distinguishes it from the others mentioned, is that of leveraging communal knowledge and the use of low-cost technologies. To this end, one of the research objectives is to develop a modular system in which various community members can collaborate in the co-creation of a robotic system using tangible interfaces. When realised, one team member will assemble a simple, low cost electronic circuit. In turn, another team member will design and craft Tangible Interface objects. The electronic circuit and the crafted object will then be integrated to form a Tangible Interface. This Tangible Interface can then be manipulated by the end user. The purpose of the electronic circuit is to sense the position and orientation of the tangible object and then send commands to a robot. Examples of robots used in the research include humanoid robots and LEGO cars (Fig. 28).

7.1 Technology

The sensing mechanism is common to all the prototypes described in this section. In these prototypes the sensing of a Tangible Interface object is accomplished through a combination of low-cost reed switches and permanent magnets. A number of reed switches are mounted on a sensing platform and magnets are embedded inside Tangible Interface objects. When a Tangible Interface object is placed on top of the sensing surface, a pre-determined combination of reed switches close. At the same time an electronic circuit senses the state of the reed switches and sends appropriate instructions to a robot for execution.

7.2 Prototypes

Cubic - and rotational Tangible Interfaces prototypes are described in the following sections.

Cubic Interfaces

Initial research at the Meraka Institute made use of acrylic sheets. These were cut according to a profile which allows assembly into a cube without the need for adhesives (Fig. 29.). Low power laser facilities at a local FabLab (Gershensfeld, 2005) were of immense value in completing this task (Smith, 2006). As a side it can be noted that FabLab is a concept which originated at the MIT Media Lab with the objective of making advanced prototyping technologies available to communities in developing regions.

The second prototype was constructed from commercially available closed-cell foam squares. These squares are manufactured in large quantities for use in baby and toddler rooms (Fig. 30.). The bright colours and soft texture afforded by these foam squares are ideal for young users of the Tangible Interfaces (Smith 2009a).

Both the acrylic- and foam cube- designs make use of a sensor matrix to detect the tangible object. This cubic configuration has been dubbed “GameBlocks”.

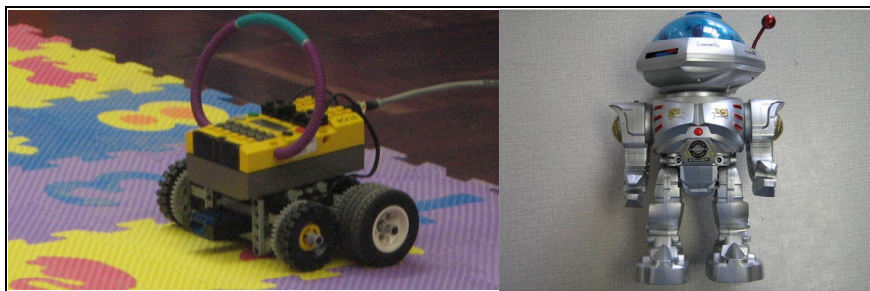

Fig. 28. Two toy robots used in the Tangible Interfaces research

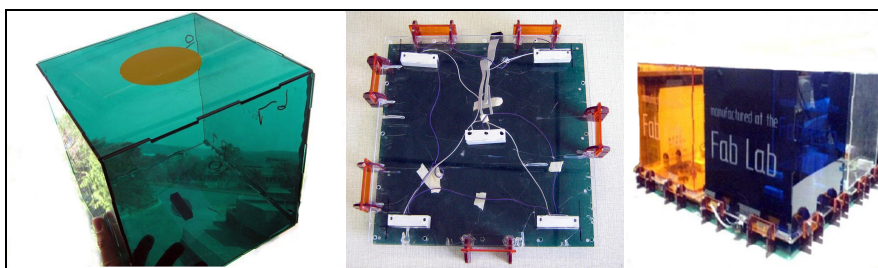

Fig. 29. The acrylic GameBlocks consists of cubes (left) and sensing trays (center)

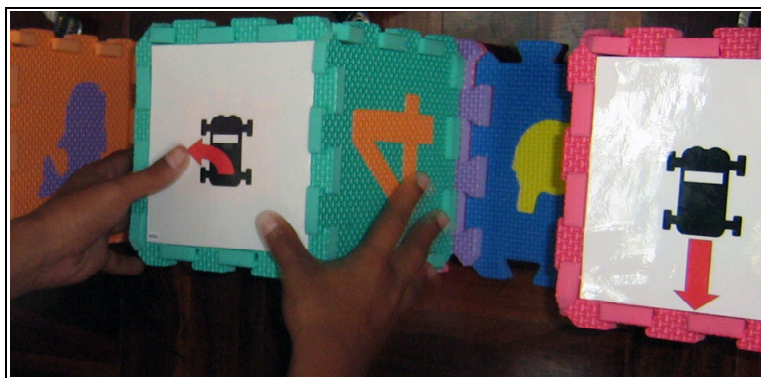

Fig. 30. Closed-cell foam GameBlocks

Rotational interfaces

A different sensor configuration was tested in the third and fourth prototype designs. In this configuration all tangible objects are identical in both shape and function, the difference being the spatial orientation of the tangible being manipulated. By changing the configuration of sensors inside the sensing surface as well as that of the embedded magnets inside the tangible, a configuration for sensing rotation was realised.

In the third prototype the properties of soft rock was explored. Using hand tools, the end user can easily shape the soft rock to create a personalized tangible (Fig. 31.). This prototype has been dubbed "RockBlocks" (Smith, 2009b).

"Dialando" is, similar to RockBlocks, a tangible interface based on rotational information. This fourth prototype demonstrates the use of recycled materials in its construction. A tangible object is constructed by sandwiching low cost magnets between two discarded CD/DVDs and finishing the construction off with a section of discarded electrical cord.

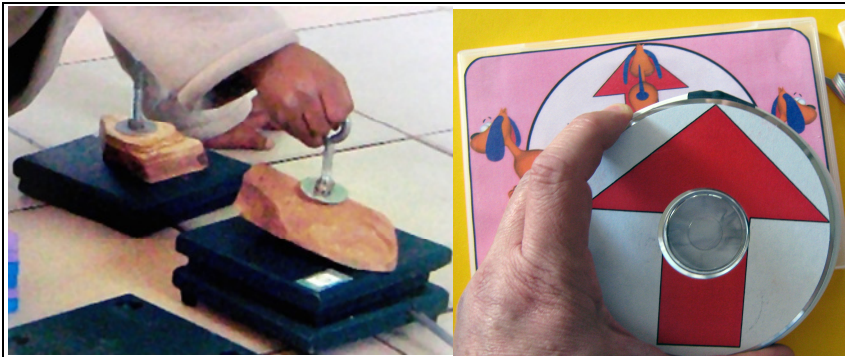

Fig. 31. RockBlocks and Dialando

7.3 Problems and solutions

A common problem experienced in various degrees is that of aligning the tangible object with the sensing surface. If the alignment is slightly out, the tangible object will either not be sensed or will be sensed incorrectly. The fourth prototype described above is an attempt to address this problem.

In an effort to reduce alignment problems a neodymium magnet was incorporated at the centre of the tangible object (Fig. 31.). A matching magnet was also positioned in the center of the sensing surface. Being of opposite polarity, the two magnets pull the tangible object into place when approaching the sensing surface, thus eliminating most of the misalignment problems experienced in the other designs.

7.4 Future work

In the design of the Dialando prototype, most of the alignment problems have been addressed through the addition of magnet-pairs. What still needs addressing is how to limit rotation of the tangible object to discrete angles. It is anticipated that this can be accomplished using a similar mechanism as that implemented for solving the misalignment between the sensing surface and the tangible object.

8. References

Camarata, K.; Do, E. Y.; Johnson, B. R. & Gross, M. D. (2002). Navigational Blocks: Navigating Information Space with Tangible Media, *IUI'02*, 2002

- Eisenberg, M.; Eisenberg, E.; & Gross, M. (2002). Khomkrit Kaowthumrong, Nathaniel Lee, and Will Lovett , Computationally-Enhanced Construction Kits for Children: Prototype and Principles, *ICLS 2002*, 2002
- Fishkin, K. P. (2004). A taxonomy for and analysis of tangible interfaces, *Personal Ubiquitous Comput.*, 8, 347-358, 2004, Springer-Verlag
- Frazer J. H. (1995). *An Evolutionary Architecture*, 1995, Architectural Association
- Gershenfeld, N.(2005); *FAB: the coming revolution on your desktop – from personal computers to personal fabrication*, Basic Books, ISBN 046-5-027466
- Hengeveld, B.; Hummels, C. & Overbeeke, K. (2009). Tangibles for Toddlers Learning Language, *Proceedings of the Third International Conference on Tangible and Embedded Interaction*, 2009, ACM
- Horn, M. S. (2009). *Tangible Computer Programming: Exploring the Use of Emerging Technology in Classrooms and Science Museums*, PhD thesis, 2009, Tufts University
- Ishii, H. (1997). *Tangible Bits: Towards Seamless Interfaces between People, Bits and Atoms*, 1997.
- Kaltenbrunner, M. & Bencina, R. (2007). reactIVision: A Computer-Vision Framework for Table-Based Tangible Interaction, *Proceedings of the 1st international conference on Tangible and embedded interaction*, 2007, ACM
- Kirton, T.; Ogawa, H.; Sommerer, C. & Mignonneau, L. (2008). PINS: A Prototype Model Towards the Definition of Surface Games, *Proceeding of the 16th ACM international conference on Multimedia*, 2008, ACM
- Mazalek, A. (2005). *Media Tables: An extensible method for developing multi-user media interaction platforms for shared spaces*, PhD dissertation, 2005, MIT
- Patten, J. M. (2005). *Mechanical Constraints as Common Ground between People and Computers*, PhD dissertation, 2005, MIT
- Raffle, H. S. (2008). *Sculpting Behavior: A tangible language for hands-on play and learning*, PhD dissertation, 2008, MIT
- Suzuki, H. & Kato, H. (1995). Interaction-level support for collaborative learning: AlgoBlock—an open programming language, *Proceedings Computer support for collaborative learning*, pp. 349-355, 1995, Lawrence Erlbaum Associates, Inc.
- Smith, A. C.; (2006). Tangible Cubes as Programming Objects, *Artificial Reality and Telexistence: 16th international conference*, pp.157-161, Hangzhou, November 2006, IEEE Computer Society.
- Smith, A. C. (2007). Using Magnets in Physical Blocks That Behave As Programming Objects, *Proceedings of the Conference on Tangible and Embedded Interaction*, 2007, ACM
- Smith, A. C.; (2008). A Low-cost, Low-energy Tangible Programming System for Computer Illiterates in Developing Regions, *Proceedings of TEDC: Technology for Innovation and Education in Developing Countries*, ISBN 978-0-620-43087-6, Kampala, August 2008, Smith, Pretoria
- Smith, A.C.; (2009a). *Symbols for Children's Tangible Programming Cubes: an Explorative Study*, *Southern African Computer Lecturers' Association Conference*, ISBN 978-1-60558-683-0, South Africa, pp. 105-109, June 2009, ACM.
- Smith, A.C.; (2009b). Hand-Crafted Programming Objects and Visual Perception, *IST-Africa 2009 Conference*, ISBN 978-1-905824-11-3, Kampala, May 2009, IIMC International Information Management Corporation.

- Spiessl, W.; Villar, N.; Gellersen, H. & Schmidt, A. (2007). VoodooFlash: Authoring across Physical and Digital Form, 2007, ACM
- Ullmer, B. & Ishii, H. (1997). The metaDESK: Models and Prototypes for Tangible User Interfaces, *Proceedings of UIST '97*, 1997, ACM
- Underkoffler, J. & Ishii, H. (1998). Illuminating light: an optical design tool with a luminoustangible interface CHI '98: *Proceedings of the SIGCHI conference on Human factors in computing systems*, pp. 542-549, 1998, ACM Press/Addison-Wesley Publishing Co.
- Underkoffler, J. & Ishii, H. (1999). Illuminating Light: A Casual Optics Workbench, *CHI 99*, 1999, ACM
- Villar, N. & Gellersen, H. (2007). A Malleable Control Structure for Soft wired User Interfaces, *Proceedings of the 1st international conference on Tangible and embedded interaction*, 2007, ACM
- Watanabe, R.; Itoh, Y.; Asai, M.; Kitamura, Y. & Kishino, F. (2004). Osaka University, and Hideo Kikuchi, The Soul of ActiveCube – Implementing a Flexible, Multimodal, Three-Dimensional Spatial Tangible Interface, *Computers in Entertainment*, Vol. 2, No. 4, Article 6b, 2004, ACM
- Yanco, H. A. & Drury, J. (2004). Classifying Human-Robot Interaction: An Updated Taxonomy, *Conference on Systems, Man and Cybernetics*, 2004, IEEE
- Zuckerman, O. (2004). *System Blocks: Learning about Systems Concepts through Hands-on Modeling and Simulation*, MSc dissertation, 2004, MIT
- Zuckerman, O.; Arida, S. & Resnick, M. (2005). Extending Tangible Interfaces or Education: Digital Montessori-inspired Manipulatives, *CHI 2005*, 2005, ACM