

The Effect of Ultrasonic Cavitation on Surficial Properties of Metals and Industrial Processes

Haitao Zheng^{1*} and Mkhulu Mathe²

¹Energy Centre, Council for Scientific and Industrial Research (CSIR), POBOX 395, Pretoria 0001, South Africa.

²University of South Africa (Unisa) Florida Campus, 28 Pioneer Ave, Florida Park, Roodepoort 1709, South Africa.

*Correspondence to: Haitao Zheng, Energy Centre, Council for Scientific and Industrial Research (CSIR), P O Box 395, Pretoria 0001, South Africa. Email: hzheng@csir.co.za

Received: July 10, 2023; Accepted: September 6, 2023; Published Online: September 12, 2023

Citation: Zheng H and Mathe M. The Effect of Ultrasonic Cavitation on Surficial Properties of Metals and Industrial Processes. *Advanced Materials Science and Technology*, 2023;5(1):0518640.

<https://doi.org/10.37155/2717-526X-0501-5>

Abstract: Ultrasonic cavitation is a phenomenon that occurs when high-frequency sound waves are introduced into a liquid medium, causing the formation and collapse of small bubbles within the liquid. These bubbles generate high-energy shock waves that can change the surface of nearby materials, leading to various physical and chemical effects. In this review, we briefly summarized the influence of ultrasonic cavitation on the surficial properties of metals and some industrial processes, particularly focusing on the effects of surface roughness, surface cleaning, and surface activation/modification and surface corrosion.

Keywords: Ultrasonic; Cavitation; Effect; Metal; Industrial process

1. Introduction

Ultrasonic cavitation refers to the formation and implosion of microscopic bubbles in a liquid medium due to the application of high-frequency ultrasonic waves. Cavitation occurs when the alternating pressure waves of the ultrasound create regions of low pressure, causing the liquid to undergo rapid expansion and contraction cycles. During the expansion phase, small gas, or vapour-filled voids, known as cavitation bubbles or cavities, are formed. When the pressure later increases during the contraction phase, these bubbles rapidly collapse or

implode. The collapses of cavitation bubbles generate localized elevated temperatures and pressures, along with intense shear forces and shock waves. This phenomenon can have several effects, depending on the specific application^[1].

The surficial properties of materials play a vital role in various fields and applications. It is crucial to understand and control the surficial properties of materials for tailoring their behaviour, improving performance, enabling specific functionalities, and ensuring compatibility with their intended applications. It is an interdisciplinary field that encompasses



materials science, chemistry, physics, engineering, and various industry-specific domains. Ultrasonic cavitation can have various effects on the surficial properties of materials depending on the specific parameters of the ultrasonic treatment, such as the frequency and power of the ultrasound waves, the duration of the treatment, and the properties of the material being treated^[2-6]. Varied materials will show varying responses to ultrasonic cavitation, and it's crucial to consider the specific application and desired outcome when utilizing this technology^[7,8].

Overall, ultrasonic cavitation can be a versatile tool for modifying the surficial properties of materials, and its effects can be tailored to specific applications by adjusting the treatment parameters. Proper control and optimization of ultrasonic parameters are necessary to achieve the desired surface effects while minimizing any negative consequences.

This review primarily focuses on summarizing the potential effects of ultrasonic cavitation on various surficial properties of materials. Specifically, it examines the impact of ultrasonic cavitation on surface roughness, surface cleaning, surface activation/modification and surface corrosion. By exploring these areas, we aim to provide a comprehensive understanding of how ultrasonic cavitation can influence the characteristics and behaviour of material surfaces, as well as some industrial processes.

2. Mechanism of Ultrasonic Cavitation and Collapse Near Solid Surfaces

The mechanism of ultrasonic cavitation near solid surfaces involves the nucleation, growth, and collapse of bubbles in a liquid medium, with the behaviour of the bubbles influenced by the proximity of the solid surface. Initially, tiny gas or vapour-filled voids, known as nuclei, are present in the liquid. These nuclei can be pre-existing gas bubbles or may form due to local pressure fluctuations or impurities in the liquid. As the high-pressure region of the sound wave passes through the liquid, the pressure on the liquid decreases, causing the nuclei to expand^[9-11]. This expansion phase is driven by the low-pressure regions created by the sound wave. As the low-pressure region of the sound wave passes through, the pressure on the liquid increases, causing the expanded nuclei to compress. This compression phase is driven by the high-pressure

regions of the sound wave. With each cycle of the sound wave, the nuclei undergo repeated expansion and compression, leading to the growth of the cavitation bubbles^[12]. The bubbles can reach a size several times larger than their initial nuclei (**Figure 1**). When these cavitation bubbles come close to solid surfaces, their behaviour can be modified due to the influence of the surface. The interaction between the cavitation bubbles and the solid surface is influenced by factors such as surface roughness, surface energy, and surface tension of the liquid. The exact mechanisms of bubble-surface interaction are complex and depend on the specific conditions^[7,13]. **Figure 1** summarized the mechanism and phenomenology of ultrasonic cavitation.

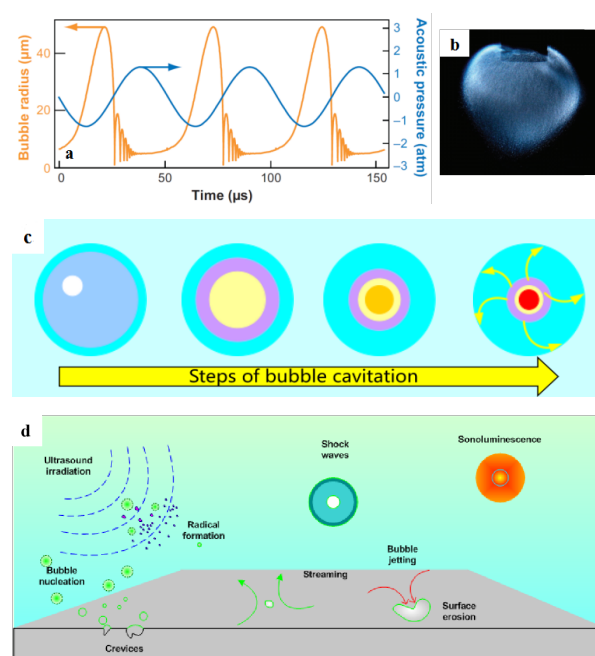

Figure 1. Summary of ultrasonic cavitation. (a) a bubble transfer in a steady state^[9]; (b) photograph of a cloud of sonoluminescent bubbles^[9]; (c) steps of bubble cavitation^[14]; (d) phenomenology of acoustic cavitation^[14]

3. The Effect of Ultrasonic Cavitation on Surface of Metals

3.1 Surface Roughness

Ultrasonic cavitation can cause the formation of tiny bubbles in liquids or solid surfaces, which then collapse violently, creating intense local pressures and temperatures. This can lead to the creation of micro-features on the surface, resulting in changes in surface roughness^[15-17]. Ultrasonication is an effective and green method to treat metallic surfaces. Simon Verdan

etc. reported the ultrasonic treatment on four different metals (Al, Ag, Cu and Zn) and the reactor for this treatment is shown in **Figure 2**^[18].

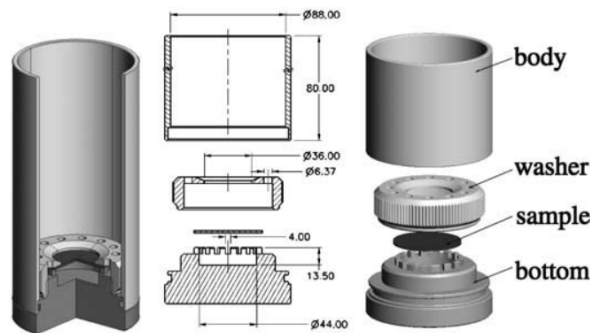

Figure 2. Reactor scheme (dimensions in mm)^[18]

When it comes to aluminum, as the distance between the sample and probe increases, the roughness significantly decreases, resulting in a less uniform treated surface. Conversely, at shorter distances, the roughness height is minimal due to the contact

between the sample and the horn, caused by ultrasound vibrations and the initial erosion of the metal surface. To achieve a consistently treated surface, the best working distance falls within the range of 0.4 mm to 0.6 mm. The results are displayed in **Figure 3**.

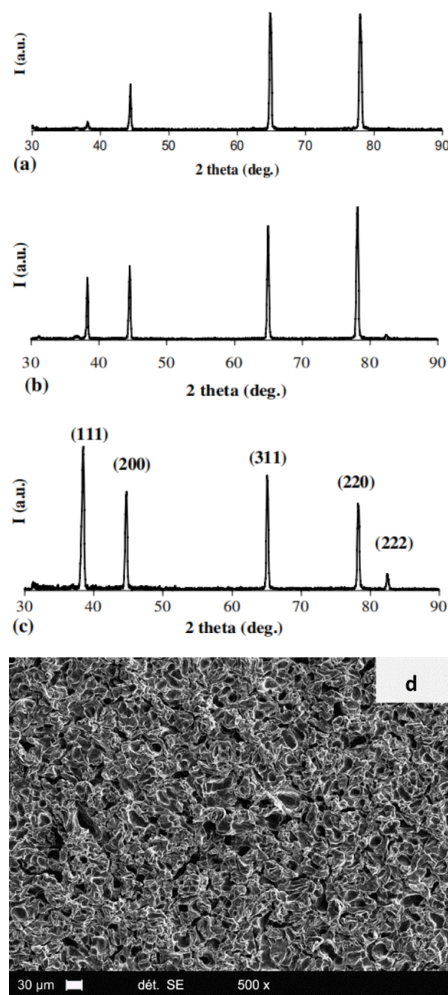

Figure 3. XRD patterns of an Al plate (a) before sonication, (b) after 3 min and (c) after 10 min; (d) scan electron micrographs (SEM) of the surface (4min); all sample-probe distance was 0.5 mm^[18]

When subjected to short sonication times, only a few impacts are visible on the metal surface. As the reaction time increases, these impacts gradually grow and multiply, ultimately covering the entire surface, creating a hammered appearance due to cavitation. SEM observations of the samples revealed the emergence of surface roughness after just 1 minute of treatment, which intensified with longer sonication durations. Surface damage was minimal for noticeably short reaction times (less than 1 minute), while it became highly uneven for longer durations (over 4

minutes).

SEM images of Cu, Ag and Zn are shown in **Figure 4** as a comparison. The copper plates' treated surface undergoes removal of its natural oxide layer, resulting in a reddish appearance lacking a shiny metallic lustre. Following a 5-minute ultrasonic treatment, the surface remains moderately affected ($R_{tm} = 17.9 \mu\text{m}$), and it takes approximately 10 minutes of reaction time to achieve a level of surface erosion comparable to that observed in aluminum, as previously described.

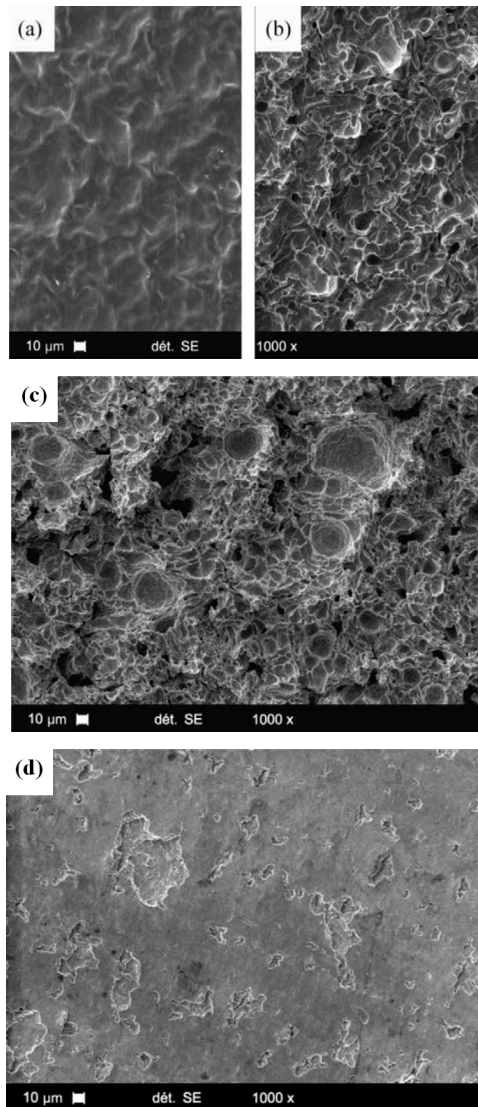

Figure 4. SEM of the surface of Cu plate after (a) 5 min and (b) 10 min of sonication; (c) Ag plate after 10 min; (d) Zn plate after 10min; all sample-probe distance was 0.5 mm^[18]

In the case of silver plates, the treated surface turns white and tarnished after sonication. SEM analysis reveals a similar pattern of surface roughness formation

and evolution as observed in aluminum. After a 5-minute ultrasonic treatment, a homogeneous erosion is observed ($R_{tm} = 13.3 \mu\text{m}$), while a 10-minute

reaction causes significant cavitation damage to the silver surface.

For Zn, the intensities of the (0 0 l) planes increased, which corresponds to the maximum density plane for a hexagonal structure.

These results suggest a structural change of the metallic surface induced by ultrasounds.

Anisotropic etched silicon is extensively used in micro-electro-mechanical systems (MEMS) for bulk micromachining^[19]. However, traditional silicon etching methods typically involve the use of environmentally and health-hazardous chemicals^[20]. To mitigate the negative impact of these chemicals, ultrasonication has been introduced to enhance the surface quality of silicon during the etching process^[21-24]. Additionally, the function of ultrasonication for surface roughness can be also used for other metals as well, such as Titanium^[25,26], steel^[27,28] and alloy^[29-31], among others.

3.2 Surface Cleaning

Ultrasonic cavitation can be an effective means of cleaning surfaces, particularly when combined with a cleaning solution. Ultrasonic cavitation can create high-speed microjets that dislodge and remove contaminants and debris from the surface of materials. Ultrasonic

cavitation can be used to remove contaminants or residues from the surface of a material, as the high-frequency pressure waves cause the formation and collapse of microscopic bubbles that generate localized pressure and temperature changes, leading to a scrubbing effect that dislodges contaminants^[32-34].

Ultrasound is considered a potential technology in improving several processes of the food industry. The significant role of ultrasonication is to obtain safer and higher quality products than with traditional procedures, such as surface cleaning and decontamination, microbial and enzymatic inactivation, degassing, defoaming, and improvement of mass transfer, among others^[35-37]. **Figure 5** illustrates the successful use of devices across various domains in the food processing industry. These devices have proven to be effective in a multitude of applications, including extraction, thawing, maturation, drying, degradation, blanching, sterilization, enzymolysis, as well as modifications on enzymes and substrate materials. Additionally, they play a crucial role in treating enzymatic hydrolysis processes, washing procedures involving pesticide removal, microorganism reduction, and supporting quality standards^[38].

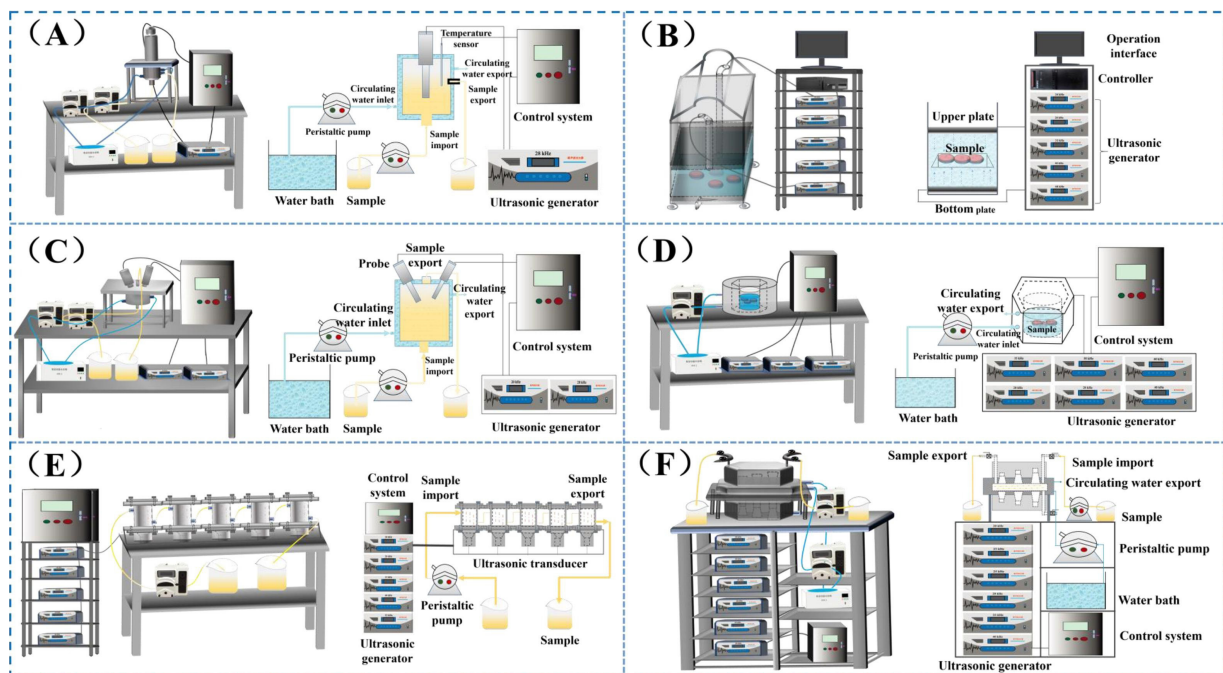

Figure 5. Various ultrasonic devices for food processing, such as extraction, thawing, maturation, drying, degradation, blanching, sterilization, and enzymolysis^[38].

Ultrasonics can benefit mineral processing through the removal of surface coatings of clay and iron oxides from mineral surfaces^[39,40]. Ultrasonication is also an efficient surface cleaning method for coal flotation^[41-43] and minerals flotation^[44] plus textile cleaning^[45-47] *etc.* The enhanced flotation performance can be attributed to two factors: improved surface cleaning effects and the presence of ultrasonic cavitation. Interactive between cavitation bubbles and coal particles, and a comparison of conventional and ultrasonic methods

for coal flotation as shown in **Figure 6**. Observation from **Figure 6** proved that ultrasonic cavitation made froth more uniform and delicate. The introduction of ultrasonic cavitation contributes to increased efficiency in favorable collision, attachment, and detachment processes. During the cleaning process, when cavitation bubbles replace clay particles, a larger number of reagents are absorbed onto the coal surface. As a result, reagent consumption during flotation is reduced, leading to more efficient flotation operations^[43].

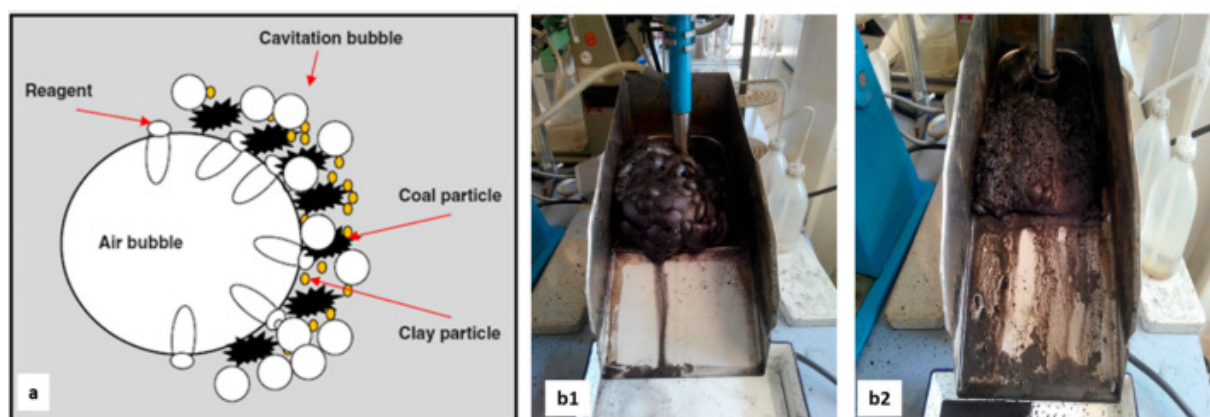

Figure 6. (a) Ultrasonic cavitation bubbles on coal flotation; photos of the coal froth (b1: conventional; b2: ultrasonic)^[48]

3.3 Surface Activation/Modification

Ultrasonic cavitation can induce localized heating and chemical reactions on the surface of a material, leading to the formation of new chemical bonds or functional groups on the surface of the material^[10,49-52]. The high-energy shockwaves generated by ultrasonic cavitation can also cause micro-scale deformation of the surface, which can alter the surface texture. This can be useful for creating surface patterns or textures for various applications^[53-55]. Ultrasonic cavitation can be used to introduce functional coatings or nanoparticles onto the surface of a material, as the cavitation bubbles can function as nucleation sites for the deposition of new materials^[15,56-58]. In some cases, ultrasonic cavitation can be used to modify the surface chemistry or structure of materials. For example, the high-energy cavitation bubbles can create reactive species such as radicals or ions that can react with the surface, leading to changes in surface chemistry or the creation of functional groups^[59-61].

Ultrasonic cavitation can induce chemical reactions and changes in the crystalline structure of materials, leading to modifications in surface properties such as

hardness, wear resistance, and corrosion resistance. However, prolonged exposure to high-intensity ultrasonic cavitation can lead to erosion and damage to the surface of materials^[33,62,63].

Most of studies of ultrasonic cavitation on surface activation/modification are applied on biomaterials^[64] and polymers^[65], such as biochar^[66], fibers^[67] *etc.*

3.4 Surface Corrosion

Cavitation corrosion, also known as cavitation erosion, is a type of mechanical damage that occurs to the surfaces of materials, particularly metals, due to the formation and collapse of cavities or bubbles in a liquid medium. Cavitation corrosion emerges when operational pressure falls below the vapor pressure of a fluid, leading to the creation of gas bubbles that implode with heightened force against material surfaces, instigating an initial stage of cavitation. During this process, known as "vena contracta", pressure drops while velocity surges. Given the corrosive nature of the fluid within the system, cavities that form initiate corrosive reactions within the affected area, triggering corrosion in response to the surrounding environment. This cavitated area has the potential to evolve into pits,

thereby setting off a sequence that may eventually lead to cracking^[68]. Most studies of cavitation corrosion are on alloys^[69-77] and steels^[78-83].

Figure 7 displays cavitation-corrosion behavior of Ni/ β -SiC nanocomposite coatings under an ultrasonic field^[84]. In **Figure 7a**, every cavitation cycle displays a pronounced and swift positive alteration in potential precisely at the onset of the cavitation process. In **Figure 7b**, the presence of cavitation conditions is marked by a noteworthy negative shift in potential. Closer scrutiny of the open circuit potential (OCP) diagrams reveals a comprehensive pattern in both

specimens, each cavitation cycle comprising four distinct potential shift phases: (1) positive change, (2) negative change during cavitation, (3) negative change, and (4) positive change during stagnation. These shifts are encapsulated in a simplified schematic, effectively depicted in **Figure 7c**. Initially, the specimen's status is represented by Point A, characterized by the corrosion potential (E_{corrA}) and the current density (i_{corrA}). The findings indicate that cavitation has the capacity to expedite both cathodic and anodic reactions, while the extent of potential shift aligns with the corrosion tendencies inherent to the materials.

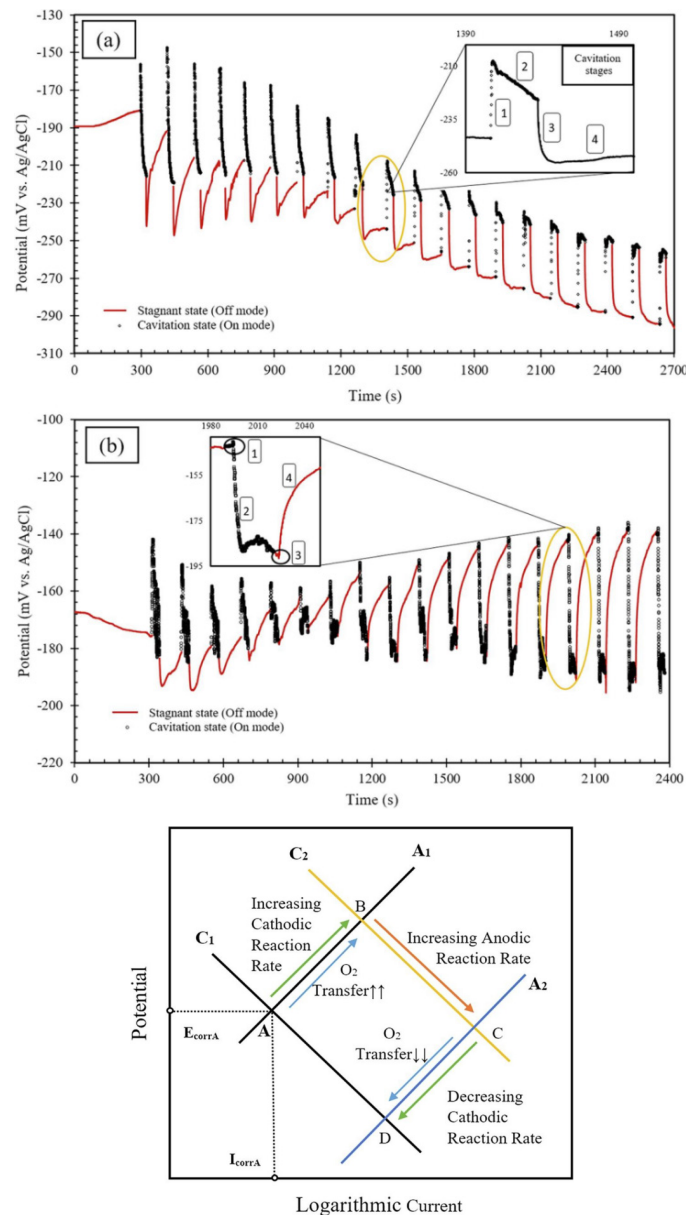

Figure 7. Free corrosion potential of (a) composite coating and (b) stainless steel substrate in 3.5 wt% NaCl; (c) schematic behavior of E_{corr} and i_{corr} vs. time in a period of cavitation/stagnant for Ni/Nano SiC composite coating and the substrate in 3.5 wt% NaCl^[84]

Selvam *et al.*^[85] reported a single-step processing technique to create a bimodal grain structure in stainless steel, as displayed in **Figure 8**. Bimodal steel showcased a remarkably robust resistance to degradation, exhibiting a nearly sevenfold increase in resistance compared to the original as-received

steel. The exceptional capacity of the bimodal steel to withstand cavitation erosion is credited to its elevated yield strength, complemented by a significant work-hardening rate. These combined attributes effectively contribute to its superior performance in resisting the erosive effects of cavitation.

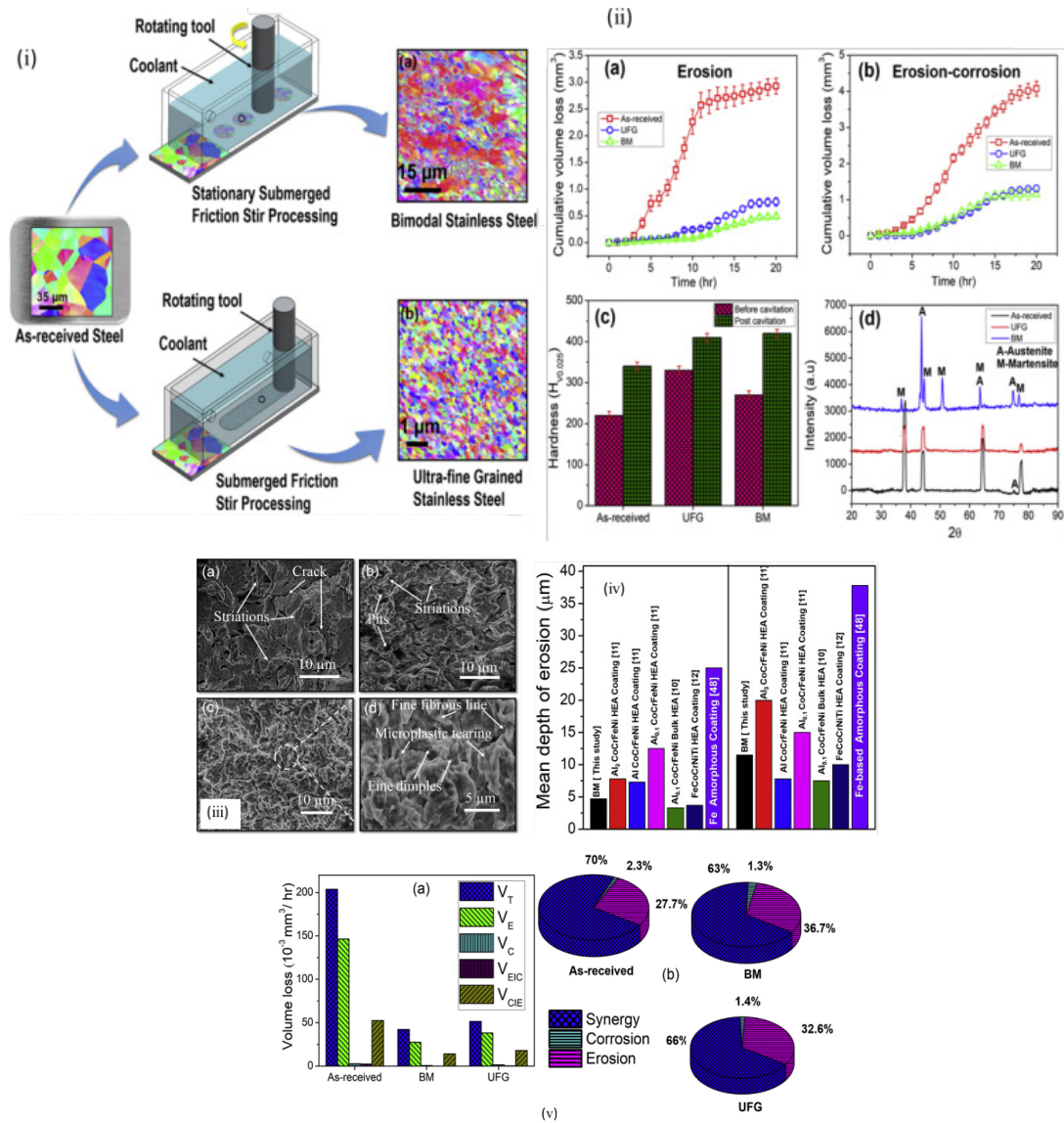

Figure 8. Schematic representation of friction stir processing for developing bimodal grain structure and ultra-fine grain structure in stainless steel (i); (a) Cumulative mass loss for all samples subjected to cavitation erosion for 20 h, (b) Cumulative mass loss for all samples subjected to cavitation erosion-corrosion for 20 h, (c) sub-surface hardness of post-cavitation (pure erosion) tested samples and (d) XRD analysis of post-cavitation tested samples (ii); SEM images for (a) as-received steel, (b) ultra-fine grain (UFG) specimen, (c) bimodal (BM) specimen, (d) zoomed in image of the region marked in (c) after 20 h of cavitation erosion (iii). Comparison of mean depth of erosion during cavitation erosion and erosion-corrosion for bimodal steel (current study) with different high entropy alloys (HEA) and amorphous coatings and bulk materials (iv). (a) Total volume loss (V_T) in 3.5% NaCl, volume loss for pure erosion (V_E), volume loss from pure corrosion (V_C), volume loss from erosion enhanced corrosion (V_{EIC}) and volume loss from corrosion enhanced erosion (V_{CIE}) for as-received, UFG and BM specimen (b) percentage contribution of individual components: erosion, corrosion, and synergy in total volume loss (v)^[85]

4. Conclusion

Ultrasonic cavitation can effectively affect the surficial properties of material, particularly metal from the perspective of surface roughness, surface cleaning, surface modification and surface corrosion.

The implosive collapse generates microjets that can remove contaminants, oxides, and debris from the metal surface. This effect is often used in ultrasonic cleaning processes.

The localized high pressures and temperatures during bubble collapse can induce plastic deformation, micro-machining, and even the formation of nanoscale features on the metal surface. This can be used for surface texturing or patterning.

The agitation caused by cavitation bubbles can enhance mass transfer processes at the metal-liquid interface, which can be advantageous in materials processing.

In some cases, the repeated collapse of cavitation bubbles can lead to cavitation erosion, which involves the gradual removal of material from the metal surface due to the mechanical stresses generated during bubble collapse.

Ultrasonication offers versatile applications in the food industry, enabling improved cleaning, extraction, emulsification, enzymatic reactions, microbial control, and texture modification. It contributes to enhanced product quality, process efficiency, and food safety.

The specific application of ultrasonic treatment in mining can indeed vary based on factors such as the ore's characteristics, the desired outcome, and the operational requirements of the mining operation. It is worth noting that ultrasonic technologies are constantly being developed and tailored to suit specific mining applications. These advancements aim to enhance efficiency, promote sustainability, and improve the overall environmental performance of the mining industry.

However, the mechanisms driving the interactions between ultrasonic cavitation and metals are complex. It is important to note that the specific effects of ultrasonication on a material's surface depend on factors such as ultrasonic frequency, power, duration, and the nature of the material itself. Optimization of these parameters is necessary to achieve the desired surface effects without causing damage.

Author's Contributions

Investigation, conceptualization, formal analysis, validation, writing-original draft: Zheng H
Writing-review and editing: Mathe M

Ethics Statement

Not applicable.

Consent for publication

Not applicable.

Availability of Supporting Data

Not applicable.

Conflict of Interest

We declare that the present work is approved for publication by all co-authors and the responsible authorities where the work was carried out.

Copyright

© The Author(s) 2023.

Reference

- [1] Laugier P and Haiat G. Introduction to the physics of ultrasound. *Bone Quantitative Ultrasound*, 2011;29-45.
https://doi.org/10.1007/978-94-007-0017-8_2
- [2] Yao C, Zhao S, Liu L, *et al.* Ultrasonic emulsification: basic characteristics, cavitation, mechanism, devices and application. *Frontiers of Chemical Science and Engineering*, 2022;16(11):1560-1583.
<https://doi.org/10.1007/s11705-022-2160-4>
- [3] Marcantonio V, Monarca D, Colantoni A, *et al.* Ultrasonic waves for materials evaluation in fatigue, thermal and corrosion damage: a review. *Mechanical Systems and Signal Processing*, 2019;120:32-42.
<https://doi.org/10.1016/j.ymsp.2018.10.012>
- [4] Singh R and Khamba JS. Ultrasonic machining of titanium and its alloys: a review. *Journal of Materials Processing Technology*, 2006;173(2):125-135.
<https://doi.org/10.1016/j.jmatprotec.2005.10.027>
- [5] Baesso RM, Costa-Felix RPB, Miloro P, *et al.* Ultrasonic parameter measurement as a means of assessing the quality of biodiesel production. *Fuel*, 2019;241:155-163.
<https://doi.org/10.1016/j.fuel.2018.12.032>

- [6] Matseke MS, Zheng H and Wang Y. The ultrasonication boosts the surface properties of $\text{CoFe}_2\text{O}_4/\text{C}$ nanoparticles towards ORR in alkaline media. *Applied Surface Science*, 2020;516:146105. <https://doi.org/10.1016/j.apsusc.2020.146105>
- [7] Shchukin DG, Skorb E, Belova V, *et al.* Ultrasonic cavitation at solid surfaces. *Advanced Materials*, 2011;23(17):1922-1934. <https://doi.org/10.1002/adma.201004494>
- [8] Munonde TS and Zheng H. The impact of ultrasonic parameters on the exfoliation of NiFe LDH nanosheets as electrocatalysts for the oxygen evolution reaction in alkaline media. *Ultrasonics Sonochemistry*, 2021;76:105664. <https://doi.org/10.1016/j.ultsonch.2021.105664>
- [9] Suslick KS and Flannigan DJ. Inside a collapsing bubble: sonoluminescence and the conditions during cavitation. *Annual Review of Physical Chemistry*, 2008;59:659-683. <https://doi.org/10.1146/annurev.physchem.59.032607.093739>
- [10] Skorb EV and Moehwald H. Ultrasonic approach for surface nanostructuring. *Ultrasonics Sonochemistry*, 2016;29:589-603. <https://doi.org/10.1016/j.ultsonch.2015.09.003>
- [11] Suslick KS. Sonochemistry. *Science*, 1990; 247(4949):1439-1445. <https://doi.org/10.1126/science.247.4949.1439>
- [12] Rooze J, Rebrov EV, Schouten JC, *et al.* Dissolved gas and ultrasonic cavitation-a review. *Ultrasonics Sonochemistry*, 2013;20(1):1-11. <https://doi.org/10.1016/j.ultsonch.2012.04.013>
- [13] Yasui K. Dynamics of acoustic bubbles. In: Grieser F, Choi PK, Enomoto N, Harada H, Okitsu K, Yasui K (editors). *Sonochemistry and the acoustic bubble*. Amsterdam: Elsevier; 2015. pp. 41-83. <https://doi.org/10.1016/B978-0-12-801530-8.00003-7>
- [14] Alarcon-Rojo AD, Carrillo-Lopez LM, Reyes-Villagrana R, *et al.* Ultrasound and meat quality: a review. *Ultrasonics Sonochemistry*, 2019;55:369-382. <https://doi.org/10.1016/j.ultsonch.2018.09.016>
- [15] Gungoren C, Ozdemir O, Wang X, *et al.* Effect of ultrasound on bubble-particle interaction in quartz-amine flotation system. *Ultrasonics Sonochemistry*, 2019;52:446-454. <https://doi.org/10.1016/j.ultsonch.2018.12.023>
- [16] Sedlaczek J, Lohmann CH, Lotz EM, *et al.* Effects of low-frequency ultrasound treatment of titanium surface roughness on osteoblast phenotype and maturation. *Clinical Oral Implants Research*, 2017;28(10):e151-e158. <https://doi.org/10.1111/clr.12976>
- [17] Udepurkar AP, Clasen C and Kuhn S. Emulsification mechanism in an ultrasonic microreactor: influence of surface roughness and ultrasound frequency. *Ultrasonics Sonochemistry*, 2023;94:106323. <https://doi.org/10.1016/j.ultsonch.2023.106323>
- [18] Verdan S, Burato G, Comet M, *et al.* Structural changes of metallic surfaces induced by ultrasound. *Ultrasonics Sonochemistry*, 2003;10(4-5):291-295. [https://doi.org/10.1016/S1350-4177\(03\)00106-8](https://doi.org/10.1016/S1350-4177(03)00106-8)
- [19] Li X and Yang H. Bulk micromachining. *3D and Circuit Integration of MEMS*, 2021;13-48. <https://doi.org/10.1002/9783527823239.ch2>
- [20] Pal P, Swarnalatha V, Rao AVN, *et al.* High speed silicon wet anisotropic etching for applications in bulk micromachining: a review. *Micro and Nano Systems Letters*, 2021;9:1-59. <https://doi.org/10.1186/s40486-021-00129-0>
- [21] Jiao Q, Tan X, Zhu J, *et al.* Effects of ultrasonic agitation and surfactant additive on surface roughness of Si (1 1 1) crystal plane in alkaline KOH solution. *Ultrasonics Sonochemistry*, 2016;31:222-226. <https://doi.org/10.1016/j.ultsonch.2015.12.019>
- [22] Swarnalatha V, Vismaya KT, Rao AVN, *et al.* Etching mechanism behind the high-speed etching of silicon in NH_2OH -added alkaline solutions. *IEEJ Transactions on Sensors and Micromachines*, 2020;140(1):24-30. <https://doi.org/10.1541/ieejsmas.140.24>
- [23] Yang CR, Chen PY, Chiou YC, *et al.* Effects of mechanical agitation and surfactant additive on silicon anisotropic etching in alkaline KOH solution. *Sensors and Actuators A: Physical*, 2005;119(1):263-270. <https://doi.org/10.1016/j.sna.2004.07.015>
- [24] Chen J, Liu L, Li Z, *et al.* Study of anisotropic etching of (1 0 0) Si with ultrasonic agitation. *Sensors and Actuators A: Physical*, 2002;96(2-

- 3):152-156.
[https://doi.org/10.1016/S0924-4247\(01\)00786-5](https://doi.org/10.1016/S0924-4247(01)00786-5)
- [25] Unursaikhan O, Lee JS, Cha JK, *et al.* Comparative evaluation of roughness of titanium surfaces treated by different hygiene instruments. *Journal of Periodontal & Implant Science*, 2012;42(3):88-94.
<https://doi.org/10.5051/jpis.2012.42.3.88>
- [26] Sato S, Kishida M and Ito K. The comparative effect of ultrasonic scalers on titanium surfaces: an in vitro study. *Journal of Periodontology*, 2004;75(9):1269-1273.
<https://doi.org/10.1902/jop.2004.75.9.1269>
- [27] Zhao W, Liu D, Zhang X, *et al.* Improving the fretting and corrosion fatigue performance of 300M ultra-high strength steel using the ultrasonic surface rolling process. *International Journal of Fatigue*, 2019;121:30-38.
<https://doi.org/10.1016/j.ijfatigue.2018.11.017>
- [28] Li L, Kim M, Lee S, *et al.* Influence of multiple ultrasonic impact treatments on surface roughness and wear performance of SUS301 steel. *Surface and Coatings Technology*, 2016;307:517-524.
<https://doi.org/10.1016/j.surfcoat.2016.09.023>
- [29] Zhang H, Chiang R, Qin H, *et al.* The effects of ultrasonic nanocrystal surface modification on the fatigue performance of 3D-printed Ti64. *International Journal of Fatigue*, 2017;103:136-146.
<https://doi.org/10.1016/j.ijfatigue.2017.05.019>
- [30] Ma C, Andani MT, Qin H, *et al.* Improving surface finish and wear resistance of additive manufactured nickel-titanium by ultrasonic nanocrystal surface modification. *Journal of Materials Processing Technology*, 2017;249:433-440.
<https://doi.org/10.1016/j.jmatprotec.2017.06.038>
- [31] Kadivar MA, Akbari J, Yousefi R, *et al.* Investigating the effects of vibration method on ultrasonic-assisted drilling of Al/SiCp metal matrix composites. *Robotics and Computer-Integrated Manufacturing*, 2014;30(3):344-350.
<https://doi.org/10.1016/j.rcim.2013.10.001>
- [32] Low ZL, Low DYS, Tang SY, *et al.* Ultrasonic cavitation: an effective cleaner and greener intensification technology in the extraction and surface modification of nanocellulose. *Ultrasonics Sonochemistry*, 2022;90:106176.
<https://doi.org/10.1016/j.ultsonch.2022.106176>
- [33] Rodič P and Milošev I. One-step ultrasound fabrication of corrosion resistant, self-cleaning and anti-icing coatings on aluminium. *Surface and Coatings Technology*, 2019;369:175-185.
<https://doi.org/10.1016/j.surfcoat.2019.03.082>
- [34] Thombre NV, Gadhekar AP, Patwardhan AV, *et al.* Ultrasound induced cleaning of polymeric nanofiltration membranes. *Ultrasonics Sonochemistry*, 2020;62:104891.
<https://doi.org/10.1016/j.ultsonch.2019.104891>
- [35] Ünver A. Applications of ultrasound in food processing. *Green Chemical and Technological Letters*, 2016;2(3):121-126.
<https://doi.org/10.18510/gctl.2016.231>
- [36] Astráin-Redín L, Raso J, Condón S, *et al.* Application of high-power ultrasound in the food industry. In: Karakuş S (editor). *Sonochemical reactions*. London: IntechOpen; 2019.
<https://doi.org/10.5772/intechopen.90444>
- [37] Dolatowski ZJ, Stadnik J and Stasiak D. Applications of ultrasound in food technology. *Acta Scientiarum Polonorum Technologia Alimentaria*, 2007;6(3):88-99.
- [38] Xu B, Azam SMR, Feng M, *et al.* Application of multi-frequency power ultrasound in selected food processing using large-scale reactors: a review. *Ultrasonics Sonochemistry*, 2021;81:105855.
<https://doi.org/10.1016/j.ultsonch.2021.105855>
- [39] Farmer AD, Collings AF and Jameson GJ. The application of power ultrasound to the surface cleaning of silica and heavy mineral sands. *Ultrasonics Sonochemistry*, 2000;7(4):243-247.
[https://doi.org/10.1016/S1350-4177\(00\)00057-2](https://doi.org/10.1016/S1350-4177(00)00057-2)
- [40] Farmer AD, Collings AF and Jameson GJ. Effect of ultrasound on surface cleaning of silica particles. *International Journal of Mineral Processing*, 2000;60(2):101-113.
[https://doi.org/10.1016/S0301-7516\(00\)00009-0](https://doi.org/10.1016/S0301-7516(00)00009-0)
- [41] Ozkan SG. Effects of simultaneous ultrasonic treatment on flotation of hard coal slimes. *Fuel*, 2012;93:576-580.
<https://doi.org/10.1016/j.fuel.2011.10.032>
- [42] Ozkan SG and Kuyumcu HZ. Investigation of mechanism of ultrasound on coal flotation. *International Journal of Mineral Processing*, 2006;81(3):201-203.

- <https://doi.org/10.1016/j.minpro.2006.07.011>
- [43] Mao Y, Xia W, Peng Y, *et al.* Ultrasonic-assisted flotation of fine coal: a review. *Fuel Processing Technology*, 2019;195:106150.
<https://doi.org/10.1016/j.fuproc.2019.10615>
- [44] Chen Y, Truong VNT, Bu X, *et al.* A review of effects and applications of ultrasound in mineral flotation. *Ultrasonics Sonochemistry*, 2020;60:104739.
<https://doi.org/10.1016/j.ultsonch.2019.104739>
- [45] Gotoh K, Harayama K and Handa K. Combination effect of ultrasound and shake as a mechanical action for textile cleaning. *Ultrasonics Sonochemistry*, 2015;22:412-421.
<https://doi.org/10.1016/j.ultsonch.2014.05.005>
- [46] Gotoh K and Harayama K. Application of ultrasound to textiles washing in aqueous solutions. *Ultrasonics Sonochemistry*, 2013;20(2):747-753.
<https://doi.org/10.1016/j.ultsonch.2012.10.001>
- [47] Mason TJ. Ultrasonic cleaning: an historical perspective. *Ultrasonics Sonochemistry*, 2016;29:519-523.
<https://doi.org/10.1016/j.ultsonch.2015.05.004>
- [48] Ozkan SG. Further investigations on simultaneous ultrasonic coal flotation. *Minerals*, 2017;7(10):177.
<https://doi.org/10.3390/min7100177>
- [49] Sun N, Zhu B, Gao X, *et al.* Improved the interfacial characteristics of carbon fiber/polyamide 6 composites by synthesizing polydopamine rapidly on the carbon fiber surface with ultrasound-assisted. *Composites Science and Technology*, 2023;234:109950.
<https://doi.org/10.1016/j.compscitech.2023.109950>
- [50] Yan L, Chen W, Li H, *et al.* Mechanism of ultrasonic vibration effects on adhesively bonded ceramic matrix composites joints. *Ceramics International*, 2021;47(23):33214-33222.
<https://doi.org/10.1016/j.ceramint.2021.08.222>
- [51] Wang H, Zhang Q, Chen Y, *et al.* Effect of ultrasonic vibration on adhesive enhancement of plasma-modified nickel surface. *Ultrasonics Sonochemistry*, 2022;89:106126.
<https://doi.org/10.1016/j.ultsonch.2022.106126>
- [52] Kishore A, John M, Ralls AM, *et al.* Ultrasonic nanocrystal surface modification: processes, characterization, properties, and applications. *Nanomaterials*, 2022;12(9):1415.
<https://doi.org/10.3390/nano12091415>
- [53] Vitry V and Bonin L. Effect of temperature on ultrasound-assisted electroless nickel-boron plating. *Ultrasonics Sonochemistry*, 2019;56:327-336.
<https://doi.org/10.1016/j.ultsonch.2019.04.027>
- [54] Chiu WK, Fracol M, Feld LN, *et al.* Judging an expander by its cover: a propensity-matched analysis of the impact of tissue expander surface texture on first-stage breast reconstruction outcomes. *Plastic and Reconstructive Surgery*, 2021;147(1):1e-6e.
<https://doi.org/10.1097/PRS.00000000000007417>
- [55] Aslam R, Alam MS, Kaur J, *et al.* Understanding the effects of ultrasound processing on texture and rheological properties of food. *Journal of Texture Studies*, 2022;53(6):775-799.
<https://doi.org/10.1111/jtxs.12644>
- [56] Paris JL and Vallet-Regi M. Ultrasound-activated nanomaterials for therapeutics. *Bulletin of the Chemical Society of Japan*, 2020;93(2):220-229.
<https://doi.org/10.1246/bcsj.20190346>
- [57] Bulychev NA. Obtaining nanosized materials in plasma discharge and ultrasonic cavitation. *High Temperature*, 2022;60(Suppl 1):S98-S126.
<https://doi.org/10.1134/S0018151X21040076>
- [58] Yamashita T and Ando K. Low-intensity ultrasound induced cavitation and streaming in oxygen-supersaturated water: role of cavitation bubbles as physical cleaning agents. *Ultrasonics Sonochemistry*, 2019;52:268-279.
<https://doi.org/10.1016/j.ultsonch.2018.11.025>
- [59] Munonde TS, Zheng H, Matseke MS, *et al.* A green approach for enhancing the electrocatalytic activity and stability of NiFe₂O₄/CB nanospheres towards hydrogen production. *Renewable Energy*, 2020;154:704-714.
<https://doi.org/10.1016/j.renene.2020.03.022>
- [60] Munonde TS, Zheng H and Nomngongo PN. Ultrasonic exfoliation of NiFe LDH/CB nanosheets for enhanced oxygen evolution catalysis. *Ultrasonics Sonochemistry*, 2019;59:104716.
<https://doi.org/10.1016/j.ultsonch.2019.104716>
- [61] Lahiri S, Mandal D, Biswas S, *et al.* Sonocatalytic recovery of ceria from graphite and inhibition of graphite erosion by ionic liquid based platinum nanocatalyst. *Ultrasonics Sonochemistry*,

- 2022;82:105863.
<https://doi.org/10.1016/j.ultsonch.2021.105863>
- [62] Moutarlier V, Viennet R, Gigandet MP, *et al.* Use of ultrasound irradiation during acid etching of the 2024 aluminum alloy: effect on corrosion resistance after anodization. *Ultrasonics Sonochemistry*, 2020;64:104879.
<https://doi.org/10.1016/j.ultsonch.2019.104879>
- [63] Costa JM and de Almeida Neto AF. Electrodeposition of nickel-tungsten alloys under ultrasonic waves: Impact of ultrasound intensity on the anticorrosive properties. *Ultrasonics Sonochemistry*, 2021;73:105495.
<https://doi.org/10.1016/j.ultsonch.2021.105495>
- [64] Foong SY, Chan YH, Yiin CL, *et al.* Sustainable CO₂ capture via adsorption by chitosan-based functional biomaterial: a review on recent advances, challenges, and future directions. *Renewable and Sustainable Energy Reviews*, 2023;181:113342.
<https://doi.org/10.1016/j.rser.2023.113342>
- [65] Ai X, Xie A, Cheng J, *et al.* Fabrication of robust and high resilient polythiophene conductive polyamides fibers based on tannic acid modification. *Industrial & Engineering Chemistry Research*, 2022;61(30):11025-11033.
<https://doi.org/10.1021/acs.iecr.2c01630>
- [66] Panahi HKS, Dehghani M, Ok YS, *et al.* A comprehensive review of engineered biochar: production, characteristics, and environmental applications. *Journal of Cleaner Production*, 2020;270:122462.
<https://doi.org/10.1016/j.jclepro.2020.122462>
- [67] Jia Z and Duan C. Preparation and characterization of surface modified ppta fibers by ultrasonic-assisted hydrogen peroxide solutions. *Fibers and Polymers*, 2019;20:2310-2316.
<https://doi.org/10.1007/s12221-019-9235-y>
- [68] Oakes BD. Cavitation corrosion. In: Ailor WH (editor). *Engine Coolant Testing: State of the Art*, ASTM STP 705. Philadelphia: American Society for Testing and Materials; 1980. pp. 284–294.
- [69] Tian Y, Zhang H, Chen X, *et al.* Effect of cavitation on corrosion behavior of HVOF-sprayed WC-10Co4Cr coating with post-sealing in artificial seawater. *Surface and Coatings Technology*, 2020;397:126012.
<https://doi.org/10.1016/j.surfcoat.2020.126012>
- [70] Du J, Zhang J, Xu J, *et al.* Cavitation-corrosion behaviors of HVOF sprayed WC-25WB-10Co-5NiCr and MoB-25NiCr coatings. *Ceramics International*, 2020;46(13):21707-21718.
<https://doi.org/10.1016/j.ceramint.2020.05.279>
- [71] Wu CL, Zhang S, Zhang CH, *et al.* Phase evolution and cavitation erosion-corrosion behavior of FeCoCrAlNiTi_x high entropy alloy coatings on 304 stainless steel by laser surface alloying. *Journal of Alloys and Compounds*, 2017;698:761-770.
<https://doi.org/10.1016/j.jallcom.2016.12.196>
- [72] Li L, Qiao Y, Zhang L, *et al.* Understanding the corrosion behavior of nickel–aluminum bronze induced by cavitation corrosion using electrochemical noise: selective phase corrosion and uniform corrosion. *Materials*, 2023;16(2):669.
<https://doi.org/10.3390/ma16020669>
- [73] Qin Z, Li X, Xia D, *et al.* Effect of compressive stress on cavitation erosion-corrosion behavior of nickel-aluminum bronze alloy. *Ultrasonics Sonochemistry*, 2022;89:106143.
<https://doi.org/10.1016/j.ultsonch.2022.106143>
- [74] Świetlicki A, Szala M and Walczak M. Effects of shot peening and cavitation peening on properties of surface layer of metallic materials—a short review. *Materials*, 2022;15(7):2476.
<https://doi.org/10.3390/ma15072476>
- [75] Kreller AK. Degradation and protection of materials from cavitation erosion: a review. *Materials*, 2023;16(5):2058.
<https://doi.org/10.3390/ma16052058>
- [76] Neville A and McDougall BAB. Erosion-and cavitation-corrosion of titanium and its alloys. *Wear*, 2001;250(1-12):726-735.
[https://doi.org/10.1016/S0043-1648\(01\)00709-8](https://doi.org/10.1016/S0043-1648(01)00709-8)
- [77] Kwok CT, Man HC, Cheng FT, *et al.* Developments in laser-based surface engineering processes: with particular reference to protection against cavitation erosion. *Surface and Coatings Technology*, 2016;291:189-204.
<https://doi.org/10.1016/j.surfcoat.2016.02.019>
- [78] Dwivedi D, Lepková K and Becker T. Carbon steel corrosion: a review of key surface properties and characterization methods. *RSC advances*, 2017;7(8):4580-4610.

- <https://doi.org/10.1039/C6RA25094G>
- [79] Qin Z, Li X, Xia DH, *et al.* The effect of compressive stress on cavitation-erosion corrosion behavior of 304 stainless steel. *Anti-Corrosion Methods and Materials*, 2022;69(4):434-441.
<https://doi.org/10.1108/ACMM-03-2022-2627>
- [80] Cao L, Qin Z, Deng Y, *et al.* Effect of passive film on cavitation corrosion behavior of 316L stainless steel. *International Journal of Electrochemical Science*, 2020;15(1):628-638.
<https://doi.org/10.20964/2020.01.51>
- [81] Zheng Z, Long J, Wang S, *et al.* Cavitation erosion-corrosion behaviour of Fe-10Cr martensitic steel microalloyed with Zr in 3.5% NaCl solution. *Corrosion Science*, 2021;184:109382.
<https://doi.org/10.1016/j.corsci.2021.109382>
- [82] Merah N, Abdul Azeem M, Abubaker HM, *et al.* Friction Stir processing influence on microstructure, mechanical, and corrosion behavior of steels: a review. *Materials*, 2021;14(17):5023.
<https://doi.org/10.3390/ma14175023>
- [83] Gupta C, Toda H, Mayr P, *et al.* 3D creep cavitation characteristics and residual life assessment in high temperature steels: a critical review. *Materials Science and Technology*, 2015;31(5):603-626.
- [84] Bakhshandeh HR, Allahkaram SR and Zabihi AH. An investigation on cavitation-corrosion behavior of Ni/ β -SiC nanocomposite coatings under ultrasonic field. *Ultrasonics Sonochemistry*, 2019;56:229-239.
<https://doi.org/10.1016/j.ultsonch.2019.04.022>
- [85] Selvam K, Saini J, Perumal G, *et al.* Exceptional cavitation erosion-corrosion behavior of dual-phase bimodal structure in austenitic stainless steel. *Tribology International*, 2019;134:77-86.
<https://doi.org/10.1016/j.triboint.2019.01.018>