

Financial benefits of integrating east–west fixed, single and dual axes tracking PV systems in the supply mix of a South African Research Campus

Henerica Tazvinga*, Enose Moholisa*, Manjunath Basappa Ayanna, Lawrence Pratt, Mluleki Hlatshwayo and Crescent Mushwana

Energy Centre, Council for Scientific and Industrial Research, P.O. Box 395, Pretoria 0001, South Africa

{htazvinga, emoholisa}@csir.co.za

Abstract

The use of Photovoltaic (PV) systems in distribution networks has increased in the past few years. The benefits of PV systems connected to the grid include reducing the carbon footprint, improving energy access, and security as well as the management of demand. The cost of PV systems has dropped rapidly in recent years, and the trend is expected to continue in future making this clean technology more attractive economically. This paper presents three different PV systems (single axis tracker, dual axis tracker and fixed rooftop) connected to the grid. Data measured over a period of a year are used in the analysis to quantify the benefits of such systems for a South African commercial entity. The results show considerable benefits attributable to the use of various PV system configurations. The outcomes of this work illustrate that the various configurations examined could result in significant benefits for industrial and commercial entities in cost reductions and addressing environmental issues.

Keywords: Tracking system, configuration, capacity utilization factors, demand charge

1 Introduction

Technological developments in recent years offer opportunities to generate clean energy from solar. The efficiency of solar photovoltaic (PV) systems has been improved, while their production costs have decreased drastically resulting in the proliferation of PV systems globally [1]. However, the output energy of a PV system depends on various factors, especially the plane of array (POA) irradiance. The POA irradiance will vary significantly depending on the mounting configuration of the array. The general rule is that solar panels should always face true south for locations in the northern hemisphere, or true north for locations in the southern hemisphere i.e. facing towards the equator (Azimuth 180° and 0° respectively). The east-west orientation is also a growing trend on flat commercial and industrial rooftops [2]. Orienting the PV array in a direction and tilt to maximize its exposure to direct sunlight will

optimize the collection efficiency. Owing to this, various techniques and various rules of thumb for tilt angle adjustments have been proposed in literature to maximize the output from PV systems throughout the year [1], [3], [4]. The power output of a PV module thus also depends on the type of mounting used which can be fixed, adjustable or tracking. The fixed type is the most common, as it is the simplest and least expensive. Tracking systems help to orient the solar module to optimize its alignment with the maximum incident beam radiation. This type can be a single-axis tracker that tracks the sun's apparent east-to-west movement across the sky or a two-axis tracker, tracking the daily east-to-west and north-south movements of the sun. The latter type is the most efficient in capturing energy from the sun and can be cost-effective if larger systems are implemented [3], [5].

Various literature [6], [7], [8], [9] has documented the financial benefits attributable to solar PV applications in the residential sector as opposed to commercial and industrial sectors. With the current reduction in PV technology prices, grid-tied solar systems can effectively help reduce peak demand if the load is shifted to the period when PV power is generated or in the commercial sector where the peak period coincides with the PV peak generation period. This enables customers to reduce demand charges thereby reducing electricity bills.

Generally, utilities price electricity and charge consumers based on total energy consumption (e.g. R/kWh) and demand consumption (e.g. R/kW) and end users such as municipalities, industries and commercial entities pay for their peak demand on the grid. Peak loads last for short periods of time making it expensive for utilities to invest in and maintain the additional generation capacity to cater for a few peak hours in a day thereby resulting in very small capacity utilization factors for the power plants. For this reason, most utilities charge an extra fee termed a demand charge or demand penalty, for high power usage. Demand charge is calculated over a short time frame, usually 15 minutes, during which overall usage is tracked and averaged. Utilities use Time of Use (TOU) tariff structures to encourage customers to shift electricity usage to periods when the charges are lower. The high tariff charged during peak periods is aimed at reducing the peak demand by penalising customers who use electricity during this period. Grid-tied systems with storage have been studied in various literature [10] [11], however, with the current cost of storage they are not as economic as those without owing to the additional cost and replacement cost of storage batteries. A study that examined various energy efficiency approaches in commercial and institutional buildings was presented in [12] but it does not address peak load reduction opportunities.

This paper analyses the benefits of PV generation from a single axis tracking system, dual axis tracking system and an east-west rooftop fixed system for a South African commercial entity. The paper also analyses the predicted and actual performances of the three grid connected systems and quantifies the energy savings to the entity, as these are crucial in determining the payback period each PV systems. The current installations serve to demonstrate the potential benefits for the entity, which can be replicated in the region as geographical location is one of the important factors that affect PV energy generation. The paper contains of the following sections: Section 2 the system description, Section 3 the methodology, Section 4 results analysis and Section 5 the conclusion.

2 System description

This section presents the description of the system used for the analysis. Figure 1 illustrates a network with three grid-tied solar PV plants which have a total capacity of 1011 kWp. This network is supplied by a Municipality grid at 132 kV, and stepped down to 11 kV medium voltage (MV) using two transformers (T1 and T2) in the main substation (M/S). The network reticulation consists of two 11 kV rings feeding substations supplying low voltage (LV) of 400V. There are multiple loads that are supplied from the network at the 400 V level.

The PV plants are integrated differently on the grid; PV system 1 (Single Axis Tracker 558 kWp) is integrated on the 11 kV Medium Voltage (MV) through a 0.4/11 kV step up transformer while PV system 2 (Dual Axis Tracker 203 kWp) and PV system 3 (Rooftop 250 kWp) are connected on the Low Voltage (LV) 400 V. The DC power generated by PV plants is converted to AC by inverters and fed into the grid, although the inverters are not shown in Figure 1.

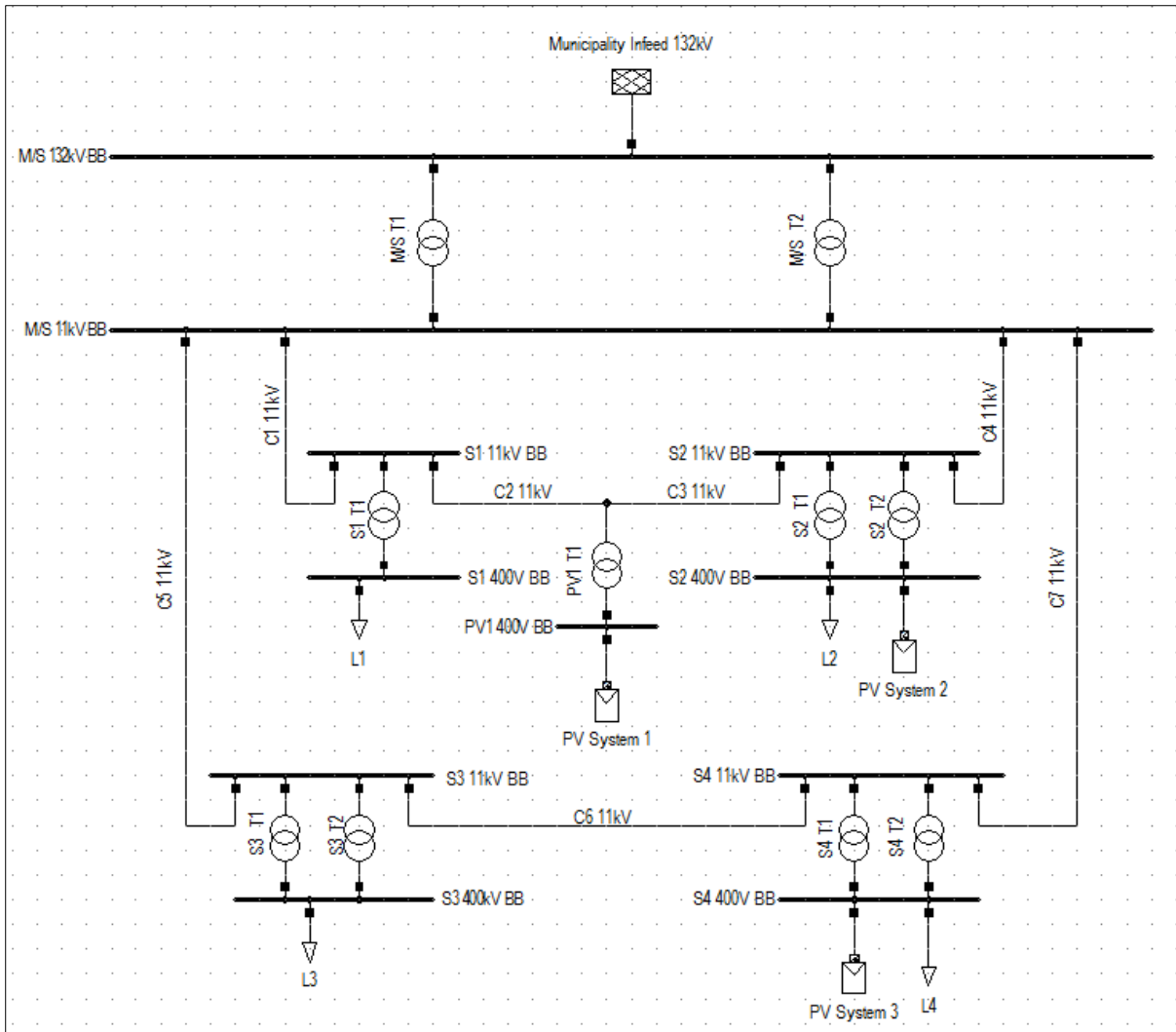

Figure 1: The single line diagram of the three PV systems connected at MV and LV levels

3 Methodology

Three solar PV plants were installed and commissioned at a South African research facility. The PV systems were installed in different configurations in two of the network rings as described in the preceding section. In order to demonstrate the efficiency of capturing energy from the sun, a single axis tracking system, dual axis tracking system and an east-west fixed system have been installed. The aim is to capture as much solar energy as possible in order to reduce the organisation's peak demand charges and energy bill using clean energy. Maximizing energy savings impacts positively on the payback periods of the systems. The predicted energy generation was calculated using PVSyst software based on historical Typical Meteorological Year (TMY) weather data.

PVSyst software is used for PV system design simulations and is one of the most widely used simulation tools in the PV industry for grid connected and stand-alone PV systems designs. Major PVSyst technical input parameters include site characteristics (e.g. geographical location, usable area), meteorological data sets (e.g. global horizontal irradiance, diffuse horizontal irradiance, ambient temperature), system characteristics (e.g. fixed or tracking, tilt & azimuth angles), technical characteristics of plant components (e.g. module, inverter) and array configuration/layout (e.g. no. of modules per string, no. of strings per inverter, distance between two rows, width of the row etc.).

The plants were installed in phases starting with the 558 kWp ground-mounted PV system (single axis tracker) which was commissioned in 2015. Its predicted levelized cost of energy (LCOE) was R 0.83/kWh with a predicted annual energy production of around 1 200 MWh. This was followed by the installation of another ground-mounted system with a capacity of 203 kWp (dual axis tracker). This was commissioned in 2016 with a predicted LCOE of R 1.00/kWh and predicted annual energy production of about 600 000 kWh. The third plant, an east-west 250 kWp rooftop mounted (fixed) PV system with a predicted LCOE of R 0.87/kWh and predicted annual energy production of about 380 000 kWh was also commissioned in 2016.

The performances of the three plants are closely monitored by comparing the predicted and the actual insolation and generation. It is important to note that insolation (kW/m^2) refers to the cumulative energy measured over some area for a defined period of time (e.g., daily, annual, monthly, etc.) while irradiance (W/m^2) is an instantaneous measurement of solar power over some area. The main performance parameters reported in this paper include total energy generated by the PV system (E_T), final yield (YF), and reference yield (YR). Total energy generated by the PV system is given by:

$$E_T = \sum_{t=1}^N E_t \quad (1)$$

where E_t is the instantaneous measured AC energy value and N is the desired duration which can be daily (e.g. 24 hours), weekly, monthly or yearly values (e.g. 8760 hours). The final yield [13] is the total AC energy generated by the PV system for a defined period (day, week, month or year) divided by the rated DC output power of the installed PV system and is expressed as:

$$Y_F = \frac{E_T}{P_{PV, rated}} \left(\frac{kWh AC}{kW DC} \right) \text{ or hours} \quad (2)$$

It represents the number of hours that the PV array would need to operate at its rated power to provide the same energy. Since it normalizes the energy produced with respect to the system size, it is a convenient way to compare the energy produced by PV systems of differing size.

The organisation is on a TOU tariff structure [14], which is used in the calculation of energy savings as shown in Table 1. Take note that 2015/2016 low demand season tariffs are not applicable because the first plant was commissioned in August 2015.

Table 1: Tariff structures for years 2015-2018 (excluding VAT)

Year	2015/2016	2016/2017	2017/2018
Low demand season (September through May)			
Peak tariff (R/kWh)	1.02	1.15 (7-10 am, 6-8 pm)	1.17
Standard tariff (R/kWh)	0.63	0.70 (remaining hours)	0.72
Off peak tariff (R/kWh)	0.44	0.50 (10 pm to 6 am)	0.51
High demand season (June, July, August)			
Peak tariff (R/kWh)	NA	3.11 (6- 9 am, 5-7 pm)	3.17
Standard tariff (R/kWh)	NA	1.07 (remaining hours)	1.09
Off peak tariff (R/kWh)	NA	0.58 (10 pm to 6 am)	0.59

4. Results analysis

In this section, results of the study are analyzed. The analyses include comparison of predicted and actual outputs of the PV systems. The savings on energy consumption and peak demand are quantified for the period considered. As already highlighted, the PV plants were commissioned at different times; therefore, the savings were derived as a new plant was brought into the energy mix.

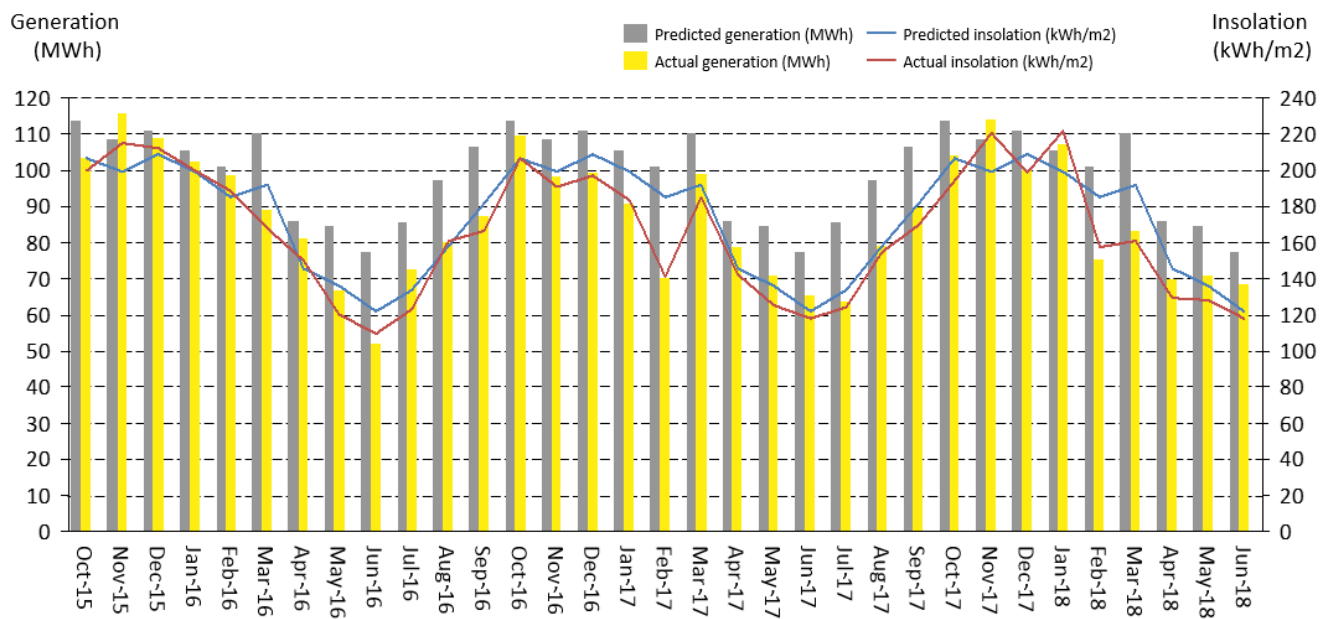

Figure 2 : Single axis tracker insolation and generation (predicted vs actual)

Figure 2 compares the predicted insolation and generation of the single axis tracking system versus the actual measured values. Generally, the predicted values are higher than the actual measured values throughout the considered period. The results also show the direct relationship between insolation and generation in both cases. Figure 3 reflects the same trend for the dual axis tracker. In Figure 4, the variation between predicted and actual values is very small for both insolation and generation showing the accuracy of the prediction model used for this period. The dashed bars show periods when either the plant or measuring system was not functioning properly.

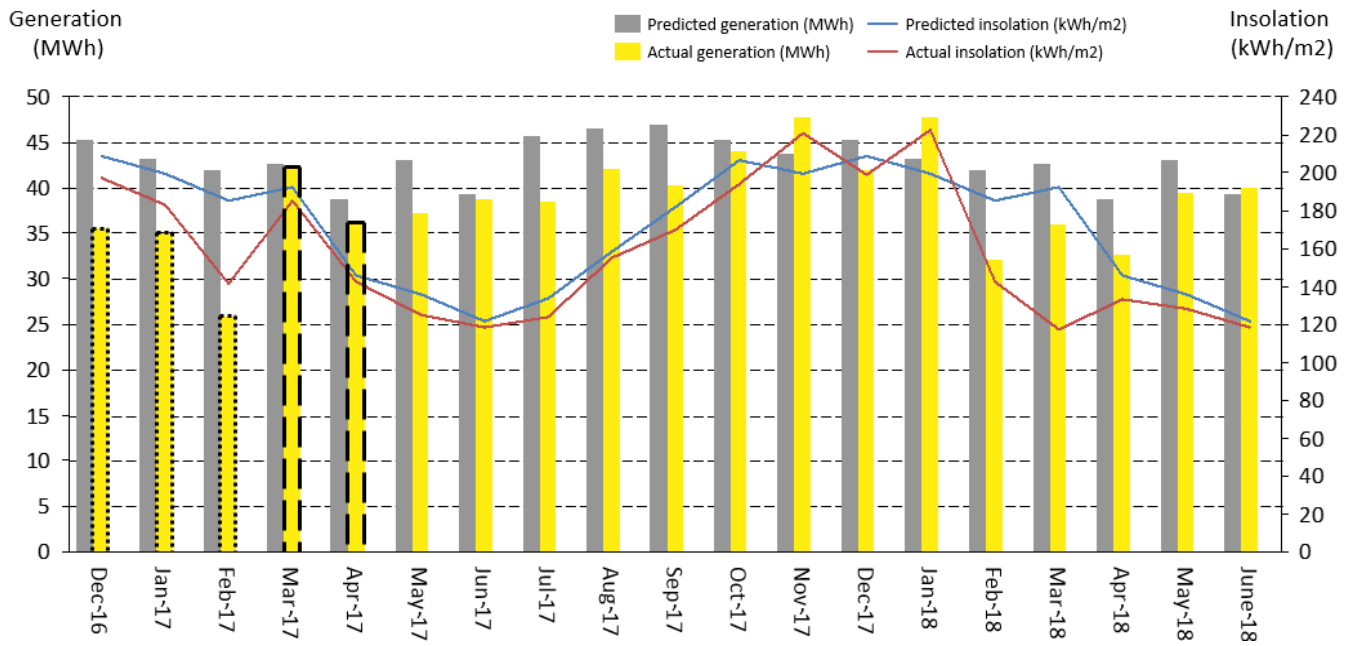

Figure 3: Dual axis tracker insolation and generation (predicted vs actual)

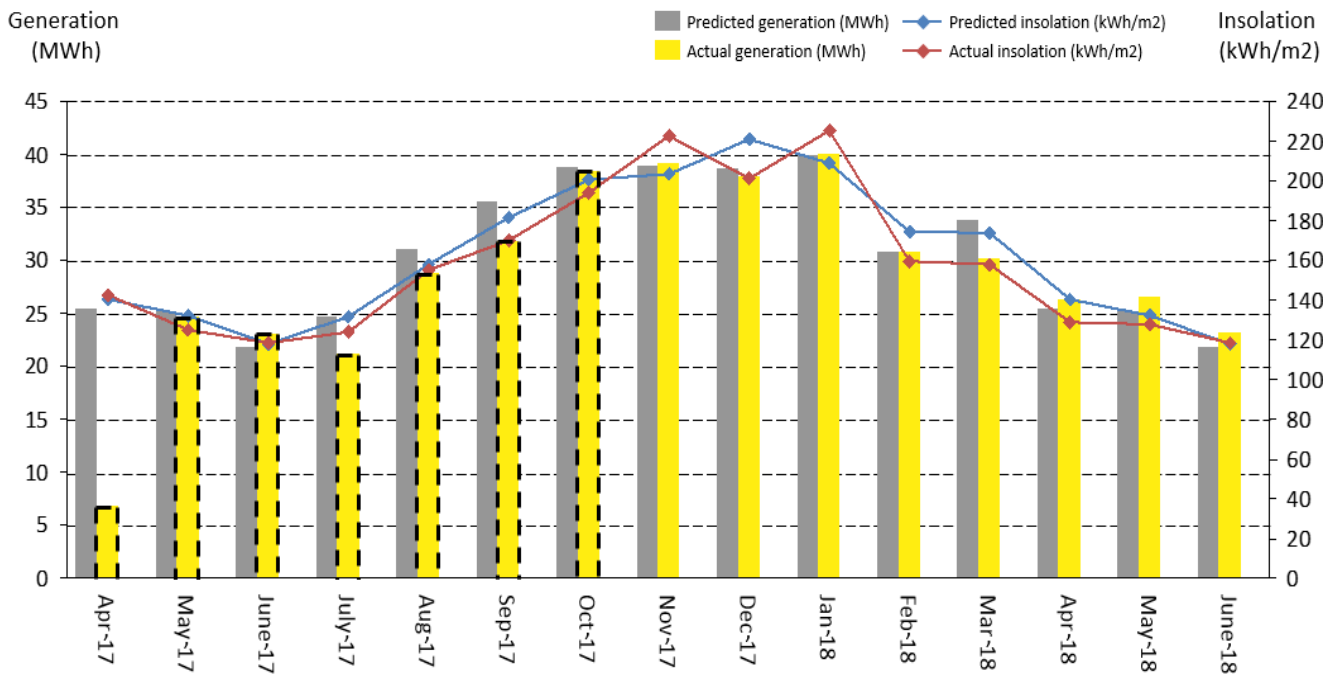

Figure 4: East-west fixed system insolation and generation (predicted vs actual)

Figure 5 and 6 show the solar PV contribution towards the organisation's monthly energy consumption and contribution towards the organisation's maximum demand reduction

respectively. The results reflect that the percentage contribution to both consumption and maximum demand increased with the increase in installed PV capacity with most contribution coming from the single axis system. In general, the contribution is higher in summer than in winter and this is expected as the demand in winter is higher than the summer demand; PV generation is also lower in winter than in summer. It is expected that the contribution is higher in summer due to the lower demand and higher PV generation. The PV plants have contributed roughly about 6% of the entity's overall energy consumption the period shown in Figure 1.

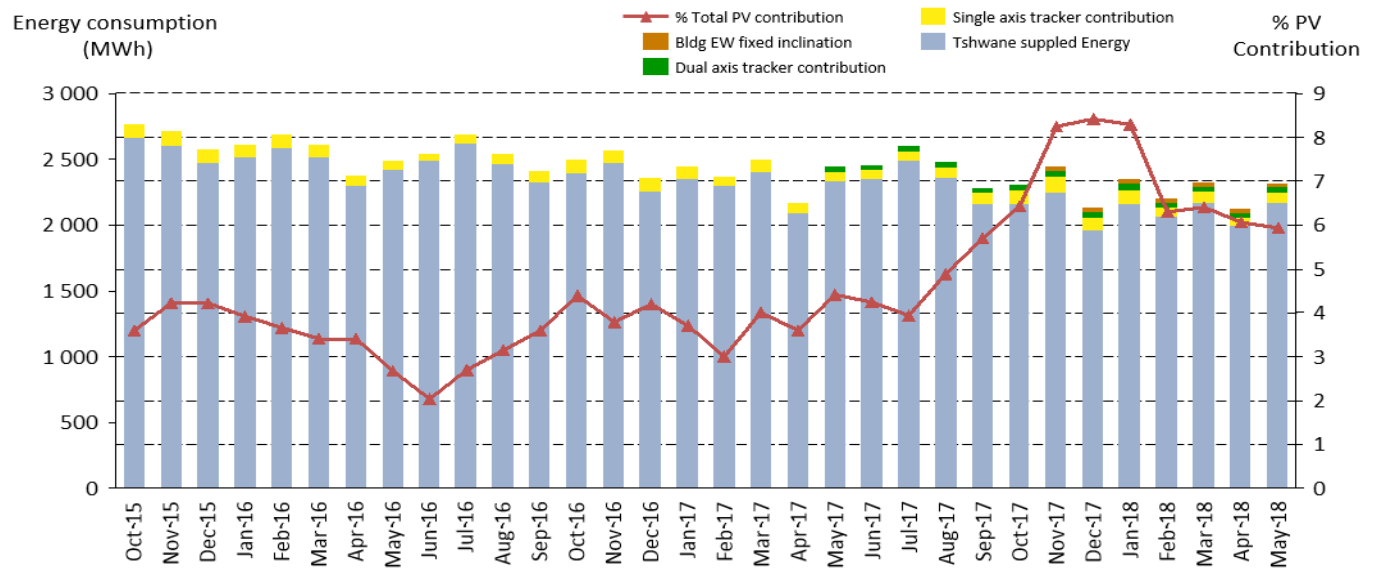

Figure 5: Solar PV monthly contribution towards organisation's total energy consumption

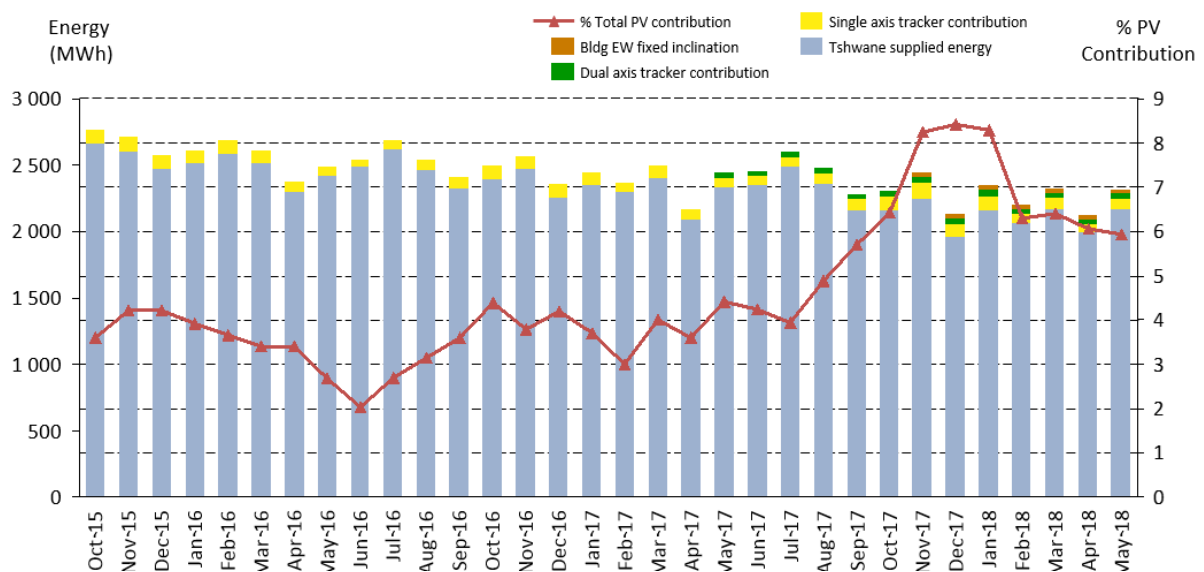

Figure 6: Solar PV monthly contribution towards organisation's maximum demand reduction

Figure 7 shows energy generation on a winter day from the three plants in which the energy generation is represented by the area under the curves. The single axis tracker produced the most energy on this day, largely due to the greater installed capacity. However, the smaller dual axis tracker plant produced more energy than the east-west fixed plant because of the normal orientation towards the sun. The wider, flatter profiles of the tracked systems illustrate their advantage over the fixed system with regard to energy harvesting.

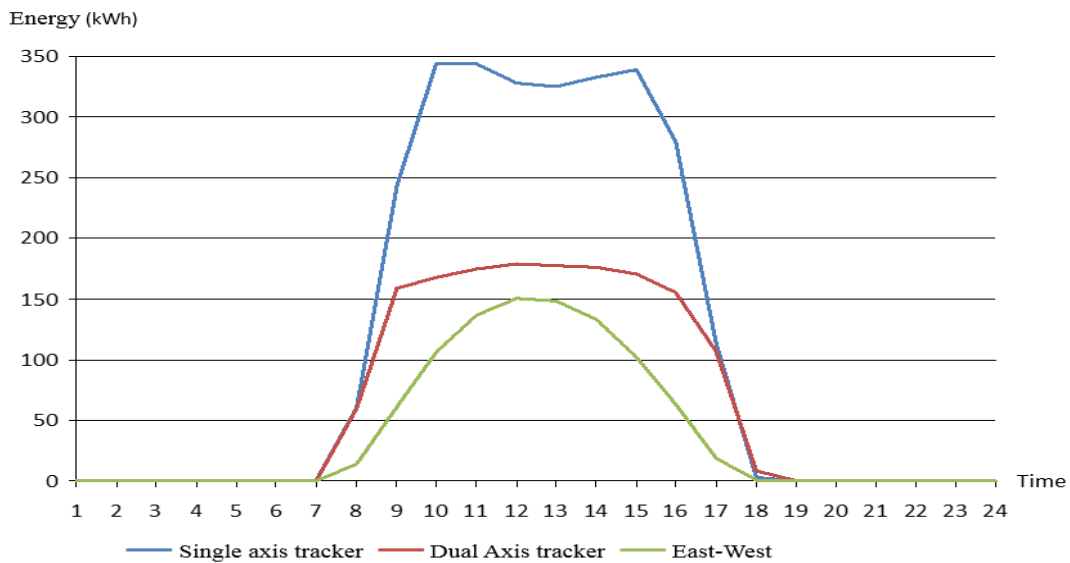

Figure 7: Energy generation on a typical winter day (2 June 2018)

Figure 8 shows the final yield for each plant, which enables a direct comparison of plants of different sizes located within the research campus. It therefore shows the production trend as if the plants were of the same installed capacity. The dual axis system produced more energy per kW installed than the single axis system, and the east-west system produced the least amount of energy. These results are expected for a clear sky condition, and the energy production is directly correlated to the plane of array irradiance incident on each system.

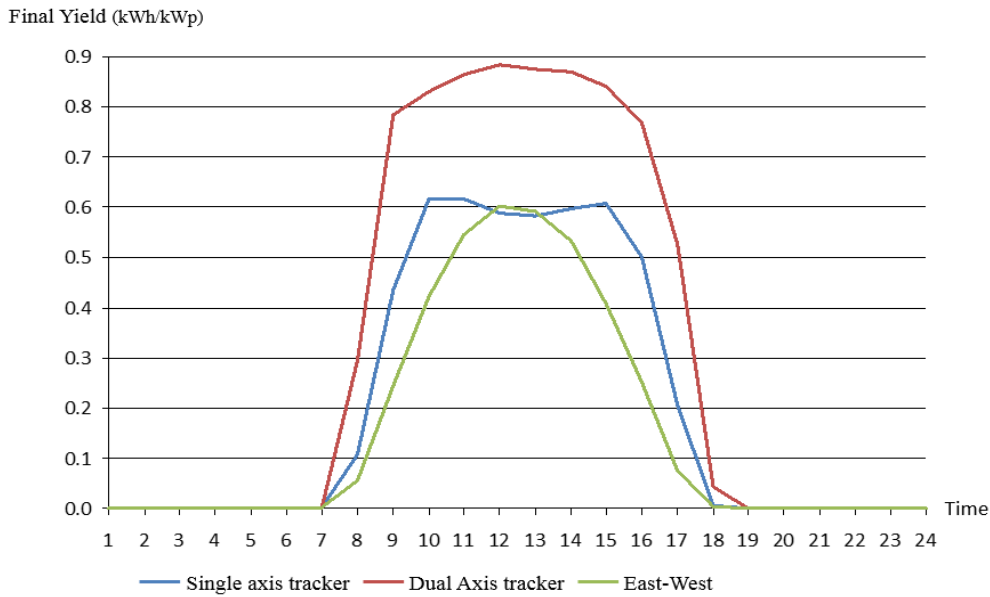

Figure 8: Final yield on a typical winter day (2 June 2018)

Table 2 shows energy generation, installed capacity, final yield, and the dual axis system gain over the other two systems based on annual final yield. Based on the final yield, for the same installed capacity the dual axis tracker would produce 29% and 58% more energy compared to single axis tracker and east-west fixed inclination systems respectively on an annual basis.

Table 2: Dual axis system gain over other systems

Parameter	Single axis tracker	Dual axis tracker	East-West
Annual generation (kWh)	1026078	479182	374459
Installed capacity (kW)	558	202	250
Final yield	1839	2369	1498
Dual axis gain over other systems	1.29		1.58

Figure 9 shows the total monthly energy savings in Rands (R) accrued by the entity and the contribution per plant over the considered period. It also shows the financial savings from peak demand reduction by all plants and per plant. For example, in November 2017 the savings totalled approximately R 230 000 with all three plants in operation. Nearly one-third of the savings was attributable to the energy production from the single axis tracker alone, while nearly one-third of the savings was attributable to the demand charge reduction from all three plants combined.

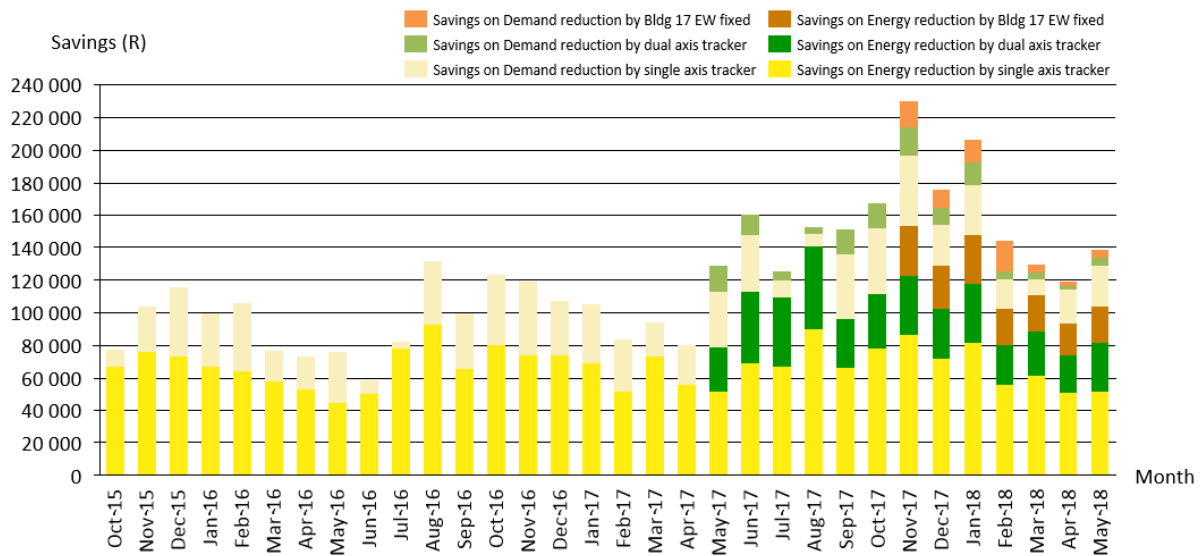

Figure 9: Monthly savings on maximum demand and energy consumption reduction by each plant

Figure 10 shows the monthly contribution of each plant towards the financial savings accrued by the research campus. The figure plots energy savings per kW of installed capacity (R/kWp) with demand charge savings on the left and energy production savings on the right. Each point represents savings from one plant for a specific month. On average, the plants saved approximately R 50/month/kWp on demand charge reductions and R 125/month/kWp on energy production, shown by the horizontal orange lines. The contribution to savings from energy production varies significantly from one plant to the next, and this is due to both installed capacity and the plane of array irradiance. The dual axis tracker saved approximately R 165/month/kWp, the single axis tracker saved approximately R120 /month/kWp, and the east-west plant saved approximately R 98 /month/kWp. The relative gain for the dual axis tracker is attributable to the higher production during the winter months when the sun path is lower in the sky, thereby reducing the plane of array irradiance on the single axis and east-west systems. Regarding demand charge savings, these data do not indicate any statistically significant difference in relative performance among the three plants. There may be some seasonal dependence on demand charges saving, but more production data and demand charge details will be required to validate this trend. The initial capital investment and the operation and maintenance of the PV plants also varied, and these details must also be considered to develop a comprehensive understanding of the relative savings from each plant.

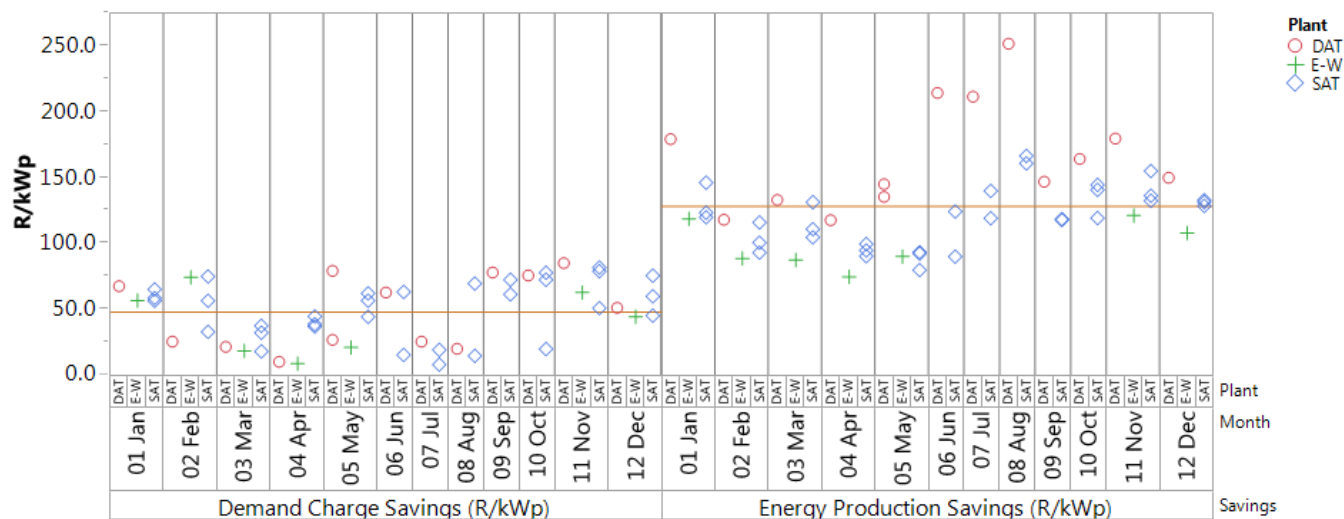

Figure 10: Monthly savings per kWp from maximum demand and energy consumption reduction by each plant

5 Conclusions

The monthly financial savings attributable to electricity generation from three PV power plants with different system configurations have been demonstrated for a research campus in Pretoria, South Africa. The PV plants have contributed roughly 6% of the overall energy consumption during the years 2015 to 2018. The energy generation profiles were matched with TOU energy pricing options offered by the local municipality to determine relative financial savings from each plant attributable to savings from energy production and savings from demand charge reductions. The monthly consumption and peak load reductions are shown to fluctuate with seasons, as expected. These data indicate the final yield (kWh AC/ kWp DC) for the dual axis tracker is 58% higher than the east-west facing plant and 29% higher than the single axis, which confirms the advantage of the tracked PV plants over the fixed plant. The monthly financial savings were shown to be primarily attributable to energy production and less attributable to demand charge savings by a ratio of 2.5:1. The cost of capital investment and the cost of operations and maintenance were not considered in this analysis.

References

- [1] M. Kacira, M. Simsek, Y. Babur and S. Demirkol, "Determining optimum tilt angles and orientations of photovoltaic panels in Sanliurfa, Turkey.," *Renewable energy*, vol. 29, no. 8, pp. 1265-1275, 2004.
- [2] M. Hartner, A. Ortner, A. Hiesl and H. R, "East to west – The optimal tilt angle and orientation of photovoltaic panels from an electricity system perspectives," *Applied Energy*, vol. 160, pp. 94-107, 2015.
- [3] V. Sharma, A. Kumar, O. Sastry and S. Chandel, "Vikrant Sharma, Arun Kumar, OPerformance assessment of different solar photovoltaic technologies under similar outdoor conditions," *Energy*, vol. 58, pp. 511-518, 2013.
- [4] J. A. Beckman and W. A. Duffie, *Solar Engineering of Thermal Processes*, New York: John Wiley & Sons, 2013.
- [5] H. Tazvinga, *Energy optimisation and management of off-grid hybrid power supply systems*, Pretoria: University of Pretoria, 2015.
- [6] Z. Wu, H. Tazvinga and X. Xia, "Demand side management of photovoltaic-battery hybrid system," *Applied Energy*, no. 148, pp. 294-304, 2015.
- [7] F. Yang and X. Xia, "Techno-economic and environmental optimization of a household photovoltaic-battery hybrid power system within demand side management," *Renewable Energy*, no. 108, pp. 132-143, 2017.
- [8] F. Sehar, M. Pipattanasomporn and S. Rahman, "An energy management model to study energy and peak power savings from PV and storage in demand responsive buildings," *Applied Energy*, no. 173, pp. 406-417, 2016.
- [9] B. Zhu and H. a. X. X. Tazvinga, "Model predictive control for energy dispatch of a photovoltaic-diesel-battery hybrid power system.," *IFAC Proceedings*, vol. 47, no. 3, pp. 11135-11140., 2014.
- [10] P. Si, Y. Feng, Y. Lv, X. Rong, Y. Pan, X. Liu and J. Yan, "An optimization method applied to active solar energy systems for buildings in cold plateau areas–The case of Lhasa," *Applied Energy*, no. 194, pp. 487-498, 2017.
- [11] J. Thakur and B. Chakraborty, "Thakur, Jagruti; Chakraborty, Basab Demand side management in developing nations: A mitigating tool for energy imbalance and peak load management," *Energy*, no. 114, pp. 895-912, 2016.
- [12] R. Ruparathna, K. Hewage and R. Sadiq, "Improving the energy efficiency of the existing building stock: A critical review of commercial and institutional buildings," *Renewable and Sustainable Energy Reviews*, no. 53, pp. 1032-1045, 2016.

[13] V. Sharma and S. Chandel, "Performance analysis of a 190 kWp grid interactive solar photovoltaic power plant in India," *Energy* 55, vol. 55, pp. 476-485, 2013.

[14] Eskom, "Tariff and Charges Booklet 2016/2017," Eskom, Johannesburg, 2016.